

**PROCUREMENT OF**  
**NON-CONSULTANCY SERVICES**  
**UNDER**  
**SHOPPING PROCEDURES**



**GOVT. OF WEST BENGAL**  
**Irrigation & Waterways Directorate**

NATIONAL HYDROLOGY PROJECT  
NH-2, Purta Bhawan, 3<sup>rd</sup> Floor, Purba Burdwan-713103  
Tel: +91342-2646799 Fax: +91342-2646799  
Email: [eebipd2012@gmail.com](mailto:eebipd2012@gmail.com) / [bengalsw@gmail.com](mailto:bengalsw@gmail.com)  
Contact details for this bidding process & documents  
Telephones: 0342-2646799 & E-mail: eebipd2012@gmail.com  
REQUEST FOR QUOTATIONS

**Procurement of Non-Consulting Services under Shopping Procedures**

**E-Procurement Notice**  
***(One-Envelope with e-Procurement Bidding Process)***

Memo No : 323 /NHP-02/02 Date: 19-08-2020

Loan No. : 8725-IN

RFQ No. : WBIW/NHP/RFQ-01/2020-21

REFERENCE : NHP-2019-2020-WBSW-835993

**Employer** : Executive Engineer, Burdwan Investigation & Planning Division  
Irrigation & Waterways Directorate Govt. of West Bengal  
Purta Bhawan, 3rd Floor Purba Burdwan-713103, West Bengal

**Applicable Procurement Guidelines** : World Bank's "Guidelines -Procurement of Goods, Works and Non-Consulting Services under IBRD Loans and IDA Credits and Grants by World Bank's Borrowers" Revised July 2014

1. The Government of India has received financing from the World Bank in various currencies towards the cost of the **National Hydrology Project** and intends to apply part of the proceeds towards eligible payments under the contract for which this request for quotations is issued. **The Executive Engineer, Burdwan Investigation & Planning Division, Irrigation & Waterways Directorate, Govt. of West Bengal, Purta Bhawan, 3rd Floor, Purba Burdwan-713103, West Bengal (for and on behalf of Irrigation & Waterways Department, Govt. of West Bengal** invites quotations electronically from eligible service providers (bidders) for the following non-consulting services.

Name of the Services	Unit	Quantity	Completion Period
<b>Survey of embankments in Hooghly District and corresponding mapping under NHP of I&amp;W Deptt., GoWB. [phase-I]</b>	<b>km</b>	<b>110</b>	<b>90 days</b>

2. This e-Procurement notice includes the terms and conditions applicable to submission of quotations; criteria for qualification, evaluation, and for award of contract; and relevant forms to be filled by the bidders. Implementing Agency has not issued a separate RFQ document for this purchase. The e-Procurement notice including the terms and conditions etc. can be downloaded free of cost by logging on to the website <https://wbtenders.gov.in>. The bidders would be required to register in the website which is free of cost.
3. For submission of Quotation, the Bidder is required to have Digital Signature Certificate (DSC) from one of the Certifying Authorities authorized by Government of India for issuing DSC. Bidders can see the list of licensed CA's from the link ([www.cca.gov.in](http://www.cca.gov.in)). Bidders who have not obtained the user ID and password for participating in e-procurement in this Project, may obtain the same from the website: <https://wbtenders.gov.in>.
4. **Quotations shall be submitted on <https://wbtenders.gov.in> on or before 15:00 hours on 10.09.2020.** Any quotation or modifications to quotation received outside e-procurement system will not be considered. The electronic bidding system would not allow late submission of quotations. **The Quotations will be opened online on 15:30 hours on 10.09.2020, this can also be viewed by the bidders online.** The electronic summary of quotation opening will be generated and uploaded online.
5. If the Employer's office happens to be closed on the date of opening of the Quotations as specified, the Quotations will be opened on the next working day at the same time.
6. Other details can be seen in the RFQ document. The Employer shall not be held liable for any delays due to system failure beyond its control. A Bidder requiring any clarification of the RFQ Document may notify the Employer online or may visit the office of the Employer at the address given below.

The Executive Engineer  
Burdwan Investigation & Planning Division,  
I&W Dte, Govt. of West Bengal.  
Purta Bhawan, 3rd Floor, Purba Burdwan-713103, West Bengal  
Telefax: +91342-2646799  
e-mail: eebipd2012@gmail.com

## Terms and Conditions

1. **Eligibility:** A Bidder (a) shall not participate in more than one Quotation; (b) shall not have conflict of interest as defined in the Bank's Procurement Guidelines; and (c) should not have been (i) temporarily suspended or debarred by the World Bank Group in compliance with the Bank's Anti-Corruption Guidelines and its Sanctions Framework; or (ii) blacklisted or suspended by Government Department/Semi-Government/Public Sector Organization in India. (d) Bids from Joint Ventures are not acceptable.
2. **Clarifications & Amendments:** If the Employer receives any request for clarification of this RFQ Document, it will upload its response together with any amendment to this document, on the e-procurement portal for information of all bidders. Bidders should check on the e-procurement system, for any amendments to the terms and conditions.
3. **The Quotation shall comprise the following:**

(All documents should be uploaded after converting the same to PDF)

- (a) Letter of Quotation;
  - (b) Authorization: The written confirmation of authorization to sign on behalf of the Bidder shall consist of an organizational document, board resolution or its equivalent, or power of attorney specifying the representative's authority to sign the Quotation on behalf of the Bidder.
  - (c) Description of services;
  - (d) Evidence in accordance with Clause 5 establishing Bidder's qualifications to perform the contract, if its quotation is accepted;
  - (e) Performance Statement of services of similar nature made during the last 3 years, in the prescribed Format along with supporting enclosures [copies of work order, schedule of work, completion certificate etc.]
  - (f) Complete address and contact details of the Bidder having the following information:  
Name of Bidder  
Address for communication  
Telephone No(s): Office  
Mobile No.  
Facsimile (FAX) No.  
Electronic Mail Identification (E-mail ID)
  - (g) Price Schedule (using the Schedule uploaded with the RFQ document) wherein the rate shall be entered online.
  - (h) **Self attested scanned copy of documents to be attached: Valid Tread License, GST certificate , PAN, P. Tax certificate , Partnership deed/ Affidavit of proprietorship duly attested by a Notary Public , IT returns, Auditors report for last three financial years showing Annual Average Turn Over etc. [ Required Annual Average Turn Over during last three Financial year ending 31<sup>st</sup> March of previous financial year should not be less than 25 lakh.[ Rupees twenty five lakh ]**
  - (i) The Bidder shall furnish, as part of his Bid, a **Bid Security** in the amount **Rs. 50,000/-** (Rupees fifty thousand only) for this particular work through Demand Draft or in the form of a Bank Guarantee (Format attached). Demand Draft to be drawn in favour of **"The Executive Engineer, Burdwan Investigation & Planning Division"** and payable at Burdwan
- Bank guarantees issued as security for the bid shall be valid for 45 days beyond the validity of the bid.

- Any bid not accompanied by an acceptable Bid Security shall be rejected by the Employer as non-responsive.
- The Bid Security of unsuccessful bidders will be return within 28 days of the end of the bid validity period.
- The Bid Security of the successful bidder will be discharged when the bidder has signed the Agreement and furnished the required Performance Security. The Bid Security of the successful Bidder shall be required to be kept valid and / or validity extended till such time the Performance Security is accepted by the Employer.
- The Bid Security may be forfeited :
  - i) if the Bidder withdraws the Bid after Bid opening during the period of Bid validity;
  - ii) in the case of a successful Bidder, if the Bidder fails within the specified time limit to : Sign the Agreement / furnish the required Performance Security.
  - j) Bidder should upload:-
    - Scanned copy of Bid security.
    - Scanned copy of Power of attorney for signing the document in the case of firm in partnership/limited company, corporation.
    - Scanned copy of an Affidavit affirming that information furnished in the bid is correct to the best of knowledge and belief of the bidder as per attached Format.

**Offline submission of Bid documents:-**

The bidders are required to submit (i) **original Power of Attorney**; (ii) **original DD / BG towards Bid Security** and (iii) **original Affidavit regarding correctness of information** furnished with bid document before the last date and time of bid submission at the address mentioned below either by registered post, courier or by hand, failing which there bids will not be opened online and will be declared nonresponsive.

**The original documents as indicated above shall be submitted in sealed envelope to the following address by 15:00 hours on 10.09.2020.**

**The Executive Engineer,  
Burdwan Investigation & Planning Division,  
I&WD, Govt. of West Bengal.  
Purta Bhawan, 3rd Floor,  
Purba Burdwan-713103, West Bengal**

The envelope should be marked (Bid name of work and Bid No.)

**4. Quotation Prices:**

- (a) The contract shall be for the whole of the services, as specified in the Price Quotation Form. Corrections, if any, can be carried out by editing the information before electronic submission.
- (b) The Bidder shall be responsible for meeting all tax liabilities other than Goods and Services Tax (GST) arising out of the Contract.
- (c) GST, which will be payable on the services at the time of invoicing, shall be shown separately.
- (d) The rates quoted by the Bidder shall be fixed for the duration of the contract and shall not be subject to adjustment on any account.

- (e) The Prices shall be quoted in Indian Rupees only.
  - (f) Each bidder shall submit only one bid.
5. **Qualification of the Bidder:** Bidder should have performed services of similar nature and complexity of value of at least **INR 20 lakh (Rupees twenty lakh)** only in any one of last 3 years. Details of services performed during the last 3 years shall be submitted in the specified Proforma. [ copy of Work orders , Schedule of works ,Completion Certificate from the competent authority for all are to be attached ]
  6. **Validity of Quotation:** Quotation shall remain valid for a period not less than 45days after the deadline date specified for submission.
  7. **Signing of Quotations:** The **name and position** held by each person signing the quotation and related documents must be typed or printed below the signature.
  8. **Quotation Submission:** The Letter of Quotation shall be filled, **signed and scanned** copies shall be uploaded along with the Price Schedules that shall be furnished using the Forms available online without any alterations. All blank spaces shall be filled in with the information requested. Scanned copies of all other documents shall also be uploaded on this website.
  9. **Deadline for Submission of Quotations:** Quotations must be uploaded online, not later than the deadline for submission of quotations by **15:00 hours on 10.09.2020** as per server time. A Bidder may modify its Quotation any number of times by using the appropriate option on the e-Procurement Portal, before the deadline for submission of Quotations. **Quotations once withdrawn cannot be resubmitted.**
  10. **Online Opening and Evaluation of Quotations:** The Quotations will be opened online on the specified date and time. This can also be viewed by the Bidder online, and electronic summary of quotation opening will be generated and uploaded online.
    - (a) The Employer shall examine the quotation to determine whether the quotation **(a)** has been properly signed (Clause 7); **(b)** meets the eligibility criteria& qualification criteria (Clause 1& 5); and **(c)** Price Schedules are in accordance with the requirements specified in the RFQ document.
    - (b) Only Quotations that are both substantially responsive to the RFQ document and meet all Qualification Criteria shall qualify for financial evaluation.
    - (c) The evaluation shall be based **excluding GST and including any other taxes.**
    - (d) Employer shall **notify in writing** those Bidders who have failed to meet the Qualification Criteria or whose Quotations were considered non-responsive to the requirements in the RFQ document, advising them that their Quotation failed to meet the requirements of the RFQ document.
  11. **Award of Contract:** The Employer will award the Contract to the Bidder whose quotation has been determined to be **substantially responsive** and who has offered the **lowest evaluated quotation price**

- (a) Notwithstanding the above, the Employer reserves the right to accept or reject any quotations and to cancel the bidding process and reject all quotations at any time prior to the award of contract.
- (b) Regarding required number of **substantially responsive bidder** ,World Bank's "Guidelines -Procurement of Goods, Works and Non-Consulting Services under IBRD Loans and IDA Credits and Grants by World Bank's Borrowers" Revised July 2014 , may be followed.
- (c) The Bidder whose quotation is accepted will be notified of the award of Contract by the Employer **prior to expiration of the quotation validity period.**
- (d) 100 % payment may be made within 30(Thirty) days of receipt of all deliverables maintaining all specifications, terms & conditions, acceptance of the same, receipt of invoice subject to availability of fund. Payment of GST for the services at the time of invoicing, although already included in the total cost, will be at actual.

**12. Performance Security: Within 15 days** of receiving Letter of Acceptance, the successful Bidder shall deliver to **The Executive Engineer, Burdwan Investigation & Planning Division, Irrigation & Waterways Directorate, Govt. of West Bengal** (Employer) the performance security (either a Bank Guarantee or a Fixed Deposit/Term Deposit Receipt in favour of the Employer) for an amount equivalent of 5(five) % of the contract price. The Performance Security shall be valid beyond 45 days the contract completion period. Failure of the successful Bidder to furnish performance security and to sign the agreement within the period stipulated shall constitute sufficient grounds for annulment of award and debarring the bidder from participation in bidding for services/works by the Employer for a period of one year, in which case the Employer may make the award to the next lowest evaluated Bidder or seek quotations afresh.

**13.** Supply of all materials and equipment shall be the responsibility of the Bidder. Employer will not issue any material/equipment.

**14. Adjudicator:**

The Adjudicator proposed by the Employer is :- **Sri Kaushik Chattopadhyay**

The daily fee for this proposed Adjudicator shall be:- **Rs. 5000.00 only.**

The biographical data of the proposed Adjudicator is:- **Ex-Secretary to the Irrigation & Waterways Department, Govt. of West Bengal**

If the Bidder disagrees with this proposal, the Bidder should so state in the Quotation. If, in the Letter of Acceptance, the Employer has not agreed on the appointment of the Adjudicator, the Adjudicator shall be appointed by the President of the Institution of Engineers, [State] State Centre at the request of either party.

# DESCRIPTION OF SERVICES

## ***1. Background:***

West Bengal specially Hooghly district crisscross with a number of rivers/khals etc. Many of these streams are used for irrigation purpose and others are mainly for drainage channels. These streams are often carry flood discharge during monsoon period. Hence an integrated data of embankment/bank of these rivers/khals are of huge importance.

## ***2. Objective(s) of the Assignment***

1. Detail topographic & hydrographic survey along rivers/khals at suitable intervals,
2. In-situ geo-technical investigation of soil samples along embankment / bank line of those rivers/khals at suitable intervals.
3. Collection of soil samples along embankment / bank line of those rivers/khals at suitable intervals & carriage of same to River Research Institute, Haringhata, West Bengal for future laboratory tests.
4. Construction of reference Bench Mark pillars along embankment / bank line of those rivers/khals at suitable intervals.

## ***3. Scope of Services, Tasks (Components) and Expected Deliverables***

### **A) Scope of Work:**

The work shall cover all technical aspects of topographic & hydrographic survey, in situ geotechnical investigation of soil samples etc. at par with standards including the following :

The survey is to be carried out using survey instruments like Total Stations, DGPS-RTK , Eco-sounder with Hypack Software and associated with GPS system to ensure accuracy and Geo-reference as per instruction of Engineer-in-Charge.

The field survey consists of:

**i)**

**a)** Detailed field survey of embankment/ and or bank of river/khal by taking cross sections @ not exceeding 250 m c/c ( extending each cross section 10 m from - country side toe line of both side embankments /country side end point of both side banks) w.r.t. G.T.S. Bench Mark value.

**b)** Carrying out closed leveling from available nearest permanent GTS Bench Mark point up to present working locations for rivers/khals throughout as per direction of Engineer-in-Charge and providing all details with X,Y,Z co-ordinates using digital level instrument at appropriate places , raw data from digital level shall be submitted along with adjusted and unadjusted levels in tabular form & by using applicable Geo-Office software as per direction of Engineer-in-Charge.

Digital leveling instrument to be used for the work shall have the minimum accuracy of order 0.30 mm per km (double run) with least count not more than 0.01 mm.

**ii)** Conducting in-situ field density test by common balance, field moisture content test by rapid moisture meter, field permeability test by constant head method [ at an average depth of 1.5 mtr from top of embankment/bank ] @500 m c/c distance along both embankments and/ or



banks and **submission of report after getting them certified by reputed Govt. organization/institute as per direction of Engineer-in-Charge.**

iii) Collection of undisturbed soil samples @1000 m c/c distance along both embankments and/ or banks from a suitable depth from top of embankment/bank & carriage of those samples with proper labeling of collection locations for assessment of different geotechnical and soil properties to River Research Institute, Haringhata, West Bengl, as per direction of Engineer-in-Charge.

iv) Construction of Bench Mark pillars as per enclosed drawing and specification. This Bench mark pillars are to be constructed at suitable locations along rivers / khals as per direction of Engineer-in-Charge. A topographic map showing location of all such B.M. pillars with Geo-reference and corresponding G.T.S. B.M. values is to be submitted [Both soft & Hard copy ] during submission of report. All those B.M. pillars are to be properly coloured and marked as per direction of Engineer-in-Charge.

#### ***4. Reporting Requirements and Time Schedule for Deliverables***

Submission of report comprising detail drawings [both soft copy & hard copy] in the form of index map, topographic site plan showing all important features, cross sections & long sections of rivers/khals in suitable scale and relevant photographs etc. as per direction of E.I.C.

a) Apart from the hard copy of report & drawings , soft copies of all survey data are to be submitted in Excel, Arc-GIS and AutoCAD format for records and further analysis.

b) A .DWG & .KMZ/.KML file of the detailed topographic survey of the embankment/ bank shall be made from the survey data such that the layer can be visualized in Google Earth/Arc GIS Earth.

Reports to be submitted time to time [after completion of one river/khal system as a whole] as per direction & satisfaction of Engineer-in-Charge.

#### **Total time period of completion of entire work : 90 days**

#### **E) Location of Rivers/Khals:**

<b>Name of Rivers/ Khals</b>	<b>Name of Block/P.S.</b>
Ghea river	Polba- Dadpur , Singur, Haripal, Jamalpur
Kunti river	Chinsura, Mogra, Polba-Dadpur ,
Kana Julkia river	Haripal, Singur
Cut Kunti Channel	Bhadreswar , Singur

#### **F) Total length of Rivers/khals [ Tentative ] : 110 km**

#### ***5. Service Provider's qualification requirement (and any other requirements which will be used for evaluation )***

The bidder shall furnish the Technical Compliance Sheet as a part of his bid with **supporting documents**; which establishing the bidder's eligibility to bid and his qualification to participate in the bid, without fulfilling the following parameter, the bidder is liable for rejection without arising any reason.

The bidder is qualified only when he is the actual service provider and meets the required norms as specified below and all original evidences to be produced in due course of time as & when asked by the Tender/Quotation Inviting Authority :

<b>TECHNICAL COMPLIANCE SHEET</b>		
<b>SI No</b>	<b>Item</b>	<b>Complied with [ Yes/No ]</b>
1	The bidder should have experience in services of similar nature & complexity.	
2	The bidder should have experienced manpower & equipment/machinery in the field of Hydrographic & Topographic Survey.	
3	The bidder should have experienced manpower & equipment/machinery in the field of Geotechnical Investigation	

**6. Employer's Input and Counterpart Personnel:**

**a) Services, facilities and property to be made available to the Service Provider by the Employer:**

- Index Map showing river network within working jurisdiction from concern Division /Sub-Division offices under Irrigation & Waterways Department, GoWB.
- Reference Bench Mark point locations and corresponding values as per availability from concern Division /Sub-Division offices under Irrigation & Waterways Department, GoWB

**b) Professional and support counterpart personnel to be assigned by the Employer to the Service Provider's team:**

- Experienced personnel to be assigned during joint field supervision / guidance etc from concern Division /Sub-Division offices under Irrigation & Waterways Department, GoWB

## **Quotation Forms**

## LETTER OF QUOTATION

*The Bidder must prepare the Letter of Quotation on stationery with its letterhead clearly showing the Bidder complete name and address. The italicized text is for Bidder's guidance in preparing these forms and shall be deleted from the final products.*

RFQ No.:*[insert identification]*

Our Reference: No..... Dated.....

To

*The Executive Engine*

*Burdwan Investigation & Planning Division,*

*I&WD, Govt. of West Bengal. Purta Bhawan, 3rd Floor,*

*Purba Burdwan-713103, West Bengal*

**Subject: Survey of embankments in Hooghly district and corresponding mapping under NHP of  
I.&W. Deptt., GoWB. [Phase –I]**

Sir,

1. We, the undersigned, hereby submit our Quotation.
2. In submitting our Quotation, we make the following declarations:
  - (a) **No reservations:** We have examined and have no reservations to the RFQ Document;
  - (b) **Quotation Validity Period:** Our Quotation shall be valid for the period of **45 days**, from the deadline fixed for the Quotation submission;
  - (c) **Eligibility:** We meet the eligibility requirements and have no conflict of interest, we are not participating in more than one quotation in this bidding process, and we have not been temporarily suspended or debarred by the World Bank or blacklisted or suspended the government department/semi-government/public sector organization in India;
  - (d) **Fraud and Corruption:** We hereby certify that we have taken steps to ensure that no person acting for us or on our behalf will engage in any type of corrupt, fraudulent, collusive, coercive, or obstructive practices; and we will strictly observe the laws against fraud and corruption in force in India namely, "Prevention of Corruption Act 1988."
  - (e) **Commissions, gratuities and fees:** We have paid, or will pay the following commissions, gratuities, or fees with respect to the Bidding process or execution of the Contract: [insert complete name of each Recipient, its full address, the reason for which each commission or gratuity was paid and the amount and currency of each such commission or gratuity. If none has been paid or is to be paid, indicate "none."]
  - (f) **We are not participating as a Joint Venture in this bidding process.**  
We accept the appointment of [name proposed in the RFQ] as the Adjudicator.  
[or]  
We do not accept the appointment of [name proposed in the RFQ] as the Adjudicator, and propose instead that [name] be appointed as Adjudicator, whose daily fees and biographical data are attached.
  - (g) The total price of our Quotation, including any unconditional discounts offered is:  
Total price of the Quotation*[insert the total price of the quotation excluding GST and including any other taxes,in words and figures]*;

Yours faithfully,

Authorized Signature\*

Name & Title of Signatory \_\_\_\_\_

In the capacity of [insert legal capacity of person signing the Letter of Quotation]

Name of Bidder \_\_\_\_\_

Address \_\_\_\_\_

Dated on \_\_\_\_\_ day of \_\_\_\_\_, \_\_\_\_\_ [insert date of signing]

\*Authorization of a person to sign on behalf of the Bidder:

The written confirmation of authorization to sign on behalf of the Bidder shall consist of an organizational document, board resolution or its equivalent, or power of attorney specifying the representative's authority to sign the Quotation on behalf of the Bidder.

## FORMAT OF QUOTATION

<b>Tender Inviting Authority: The Executive Engineer, Burdwan Investigation &amp; Planning Division</b>								
<b>Name of Work: "Survey of embankments in Hooghly District [phase-I] and corresponding mapping under NHP of I&amp;W Deptt.,GoWB."</b>								
<b>Contract No: WBIW/NHP/RFQ- 01 /2020-21</b>								
<b>Name of the Bidder/ Bidding Firm / Company :</b>								
<b><u>PRICE SCHEDULE</u></b>								
<b>(This BOQ template must not be modified/replaced by the bidder and the same should be uploaded after filling the relevent columns, else the bidder is liable to be rejected for this tender. Bidders are allowed to enter the Bidder Name and Values only)</b>								
<b>NUMBER #</b>	<b>TEXT #</b>	<b>NUMBER #</b>	<b>TEXT #</b>	<b>NUMBER #</b>	<b>NUMBER #</b>	<b>NUMBER #</b>	<b>NUMBER #</b>	<b>TEXT #</b>
<b>Sl. No.</b>	<b>Item Description</b>	<b>Quantity</b>	<b>Units</b>	<b>Quoted Unit Rate with all taxes and all incidental charges excluding GST in INR</b>	<b>Total GST applicable per item in INR</b>	<b>TOTAL AMOUNT Without Taxes [Col. (4*13)]</b>	<b>TOTAL AMOUNT With Taxes [Col. (51 + 53)]</b>	<b>TOTAL AMOUNT In Words</b>
<b>1</b>	<b>2</b>	<b>4</b>	<b>5</b>	<b>13</b>	<b>51</b>	<b>53</b>	<b>54</b>	<b>55</b>
1	Survey of embankments and corresponding mapping							

1.01	<p>Detailed field survey of embankments and/or banks along various rivers/khals confined within 01(one) district by using instruments like total station, RTK-DGPS, Eco-sounder etc by taking total alignment with geo-referencing and plotting on Google map including cross sections of river/khal @250 m c/c (extending each cross section 10 m from - country side toe line of both side embankments /country side end point of both side banks)w.r.t. G.T.S. Bench Mark (including flying of G.T.S. Bench Mark from nearest available locations upto present working locations)and submission of report comprising detail drawings [both soft copy (in .DWG &amp; .KMZ/KML format &amp; must be geo-referenced) &amp; hard copy] in the form of index map, topographic site plan showing all important features, cross sections &amp; long sections of rivers/khals with min suitable scale and relevant photographs etc. as per direction &amp; satisfaction of E.I.C.----- complete.</p> <p>Note i)The rate is inclusive of all incidental charges like all types of carriage ,engagement of manpower &amp; instruments/equipment etc. as applicable to complete to work in all respect.</p>	110	per km of river/ khal		0.000	0.000	INR Zero Only
1.02	<p>Conducting in-situ field density test by common balance ,field moisture content test by rapid moisture meter, field permeability test by constant head method [at an average depth of 1.5 mtr from top of embankment/bank] @500 m c/c distance along both embankments and/ or banks and submission of report after getting them certified by reputed Govt. organization/institute as per direction &amp; satisfaction of E.I.C. -----complete.</p> <p>Note i)The rate is inclusive of all incidental charges like all types of carriage ,engagement of manpower &amp; instruments/equipment etc. as applicable to complete to work in all respect.</p>	221	each location		0.000	0.000	INR Zero Only
1.03	<p>Collection of undisturbed soil samples @1000 m c/c distance along both embankments and/ or banks from a suitable depth from top of embankment/bank &amp; carriage of those samples with proper labeling of collection locations as per requirement for assessment of different geotechnical and soil properties to RRI, Haringhata, WB , as per direction &amp; satisfaction of E.I.C. -----complete.</p> <p>Note i)The rate is inclusive of all incidental charges like all type carriage ,engagement of</p>	111	each location		0.000	0.000	INR Zero Only

	manpower & instruments/equipment etc. as applicable to complete to work in all respect.							
1.04	Erection of Bench Mark pillar as per enclosed details at various locations with following specification : Cast-in Situ RCC made benchmark pillar of size 0.3 m x 0.30 m x 1.5 m ( 0.60 m above G.L. & buried 0.90 m below G.L.) with cement concrete nominal mix grade of 1:1.5:3 , 4 nos of vertical bars of 10 mm dia& stirrups of 8 mm dia @ 150 mm c/c ,including one 6 mm thick 50 mm dia GI pipe inserted within concrete with 100 mm x 100 mm x 6 mm mild steel plate fixed by weldin atop ,painting ,lettering as per enclosed drawing and as per direction & satisfaction of E.I.C. -----complete. Note i) The rate is inclusive of all charges like all materials, all type carriage upto site ,lead and lift ,all labours ,all concrete related items ,painting, lettering including all appurtenances ,tools & plants etc. as applicable to complete to work in all respect.	25	each B.M. pillar			0.000	0.000	INR Zero Only
<b>Total in Figures</b>						0.00	0.00	INR Zero Only
<b>Quoted Rate in Words</b>	<b>INR Zero Only</b>							

*\*Payment of GST payable for the services at the time of invoicing, although already included in the total cost, will be at actual.*

We agree to perform the above services in accordance with the Description of Services for a total contract price (including all taxes and duties) of INR. ....(Amount in figures)(Indian Rupees ..... amount in words) [insert total price exclusive GST and inclusive any other taxes]within the period specified in the Request for Quotations.

We hereby certify that we have taken steps to ensure that no person acting for us or on our behalf has engaged in corrupt, fraudulent, collusive, coercive, or obstructive practices (as defined in the prevailing World Bank's sanctions procedures) in competing for or in performing the Contract.

**Signature of Bidder with seal**

## PROFORMA FOR PERFORMANCE STATEMENT

RFQ No. -----

Name of Bidder -----

*[for a period of last 03 financial years ]*

NAME OF WORK	WORK ORDER REFERENCE	ORDER PLACED BY	DESCRIPTION OF SERVICES	VALUE OF ORDER	DATE OF COMPLETION	VALUE OF SERVICES AT COMPLETION	REMARKS IF ANY

**SIGNATURE OF BIIDDER**



# PERFORMANCE BANK GUARANTEE

*(To be given from a nationalized or scheduled bank in India)*

To:

*The Executive Engine*

*Burdwan Investigation & Planning Division,*

*I&WD, Govt. of West Bengal. Purta Bhawan, 3rd Floor,*

*PurbaBurdwan-713103*

*West Bengal*

Whereas *[name and address of Service Provider]* (hereinafter called “the Service Provider”) has undertaken, in pursuance of Contract No. *[number]* dated *[date]* to execute : **Survey of embankments in Hooghly District and corresponding mapping under NHP of I&W Deptt., GoWB. [Phase-I]** (hereinafter called “the Contract”);

And whereas it has been stipulated by you in the said Contract that the Service Provider shall furnish you with a Bank Guarantee by a recognized bank for the sum specified therein as security for compliance with his obligations in accordance with the Contract;

And whereas we have agreed to give the Service Provider such a Bank Guarantee;

Now therefore we hereby affirm that we are the Guarantor and responsible to you, on behalf of the Service Provider, up to a total of *[amount of Guarantee]* *[amount in words]*, such sum being payable in the types and proportions of currencies in which the Contract Price is payable, and we undertake to pay you, upon your first written demand and without cavil or argument, any sum or sums within the limits of *[amount of Guarantee]* as aforesaid without your needing to prove or to show grounds or reasons for your demand for the sum specified therein.

We hereby waive the necessity of your demanding the said debt from the Service Provider before presenting us with the demand.

We further agree that no change or addition to or other modification of the terms of the Contract or of the Services to be performed there under or of any of the Contract documents which may be made between you and the Service Provider shall in any way release us from any liability under this Guarantee, and we hereby waive notice of any such change, addition, or modification.

This Guarantee shall be valid until a date 45 days from the date of completion of the Services.

Signature and seal of the Guarantor

Name of Bank

Address

Date

**FORM OF AFFIDAVIT FOR CORRECTNESS OF INFORMATION AND  
DOCUMENTS SUBMITTED WITH BID**

[This affidavit should be on a non-judicial stamp paper of Rs.10/- and shall be attested by Magistrate/ Sub-Judge/ Notary Public]

I, .....(name of the authorized representative of the Bidder) solemnly affirm and state as under:

1. I hereby certify that all the information and documents furnished with the Bid submitted online in response to IFB number ..... date ..... issued by ..... (authority inviting bids) for ..... (name and identification of work) are true and correct.

2. \*I hereby certify that I have been authorized by ..... (the bidder) to sign on their behalf, the Bid mentioned in paragraph 1 above.

Deponent

Place: .....

Date: .....

\* This sub-paragraph is not applicable if the Bidder is an individual and is signing the Bid on his own behalf.

# LETTER OF ACCEPTANCE

*[letterhead paper of the Employer]*

*[date]*

To: *[name and address of the Bidder]*

This is to notify you that your Quotation dated *[date]* for execution of the *[name of the Contract and identification number as given in RFQ]* for the Contract Price of the equivalent of INR *[amount in numbers and words]*, as corrected and modified in accordance with Request for Quotations (RFQ) is hereby accepted by our Agency.

Note : Insert one of the 3 options for the second paragraph. The first option should be used if the Bidder has not objected the name proposed for Adjudicator. The second option if the Bidder has objected the proposed Adjudicator and proposed a man for a substitute, who was accepted by the Employer. And the third option if the Bidder has objected the proposed Adjudicator and proposed a man for a substitute, who was not accepted by the Employer.

We confirm that [ insert name proposed by Employer in the RFQ ]

**or**

We accept that [ name proposed by bidder] be appointed as the Adjudicator

**or**

We do not accept that [ name proposed by bidder] be appointed as Adjudicator , and by sending a copy of this letter of acceptance to [ insert the name of the Appointing Authority] , we are hereby requesting [ name ] , the Appointing Authority , to appoint the Adjudicator in accordance with RFQ.

You are hereby requested to furnish **performance security** for an amount of INR \_\_\_\_\_ *[equivalent to 5% of the contract price]* within 15 days of the receipt of the letter. The Performance Security in the form of Bank guarantee or a Fixed Deposit/ Term Deposit Receipt in favour of..... (Employer) shall be valid beyond **45** days the contract completion period. Failure to furnish the Performance Security will entail cancellation of the award of contract.

You are also requested to return the Contract Agreement duly signed.

Authorized Signature:

Name and Title of Signatory:

Name of Agency:

Attachment: Contract Agreement

# DRAFT CONTRACT AGREEMENT

1. This deed of agreement is made in the form of agreement on \_\_\_\_\_ day \_\_\_\_\_ month \_\_\_\_\_ 20\_\_\_\_, between the \_\_\_\_\_ (Employer) or his authorized representative (hereinafter referred to as the first party) and \_\_\_\_\_ (Name of the Service Provider), S/O \_\_\_\_\_ resident of \_\_\_\_\_ (hereinafter referred to as the second party), to execute the non-consulting services of: **Survey of embankments in Hooghly District and corresponding mapping under NHP of I&W Deptt., GoWB. [Phase –I]**

(hereinafter referred to as services) on the following terms and conditions.

## 2. Contract Price

The total Contract Price for the services (hereinafter referred to as the “total price”) is INR (excluding/including(*Choose one option*)Goods and Services Tax).

### 2.1. Payments under the Contract

Payments to the second party for the services will be released by the first party in the following manner:

100% Payment to the second party for the works/services will be released by the first party after completion of all works/services as per schedule-specification by maintaining all terms & condition and receipt & acceptance of all deliverables as a whole as per direction & satisfaction of Engineer-in- charge.

2.2 Payments will be made on certification of the invoice by the Project Manager nominated by the first party with respect to quality/quantity of services executed in the format in **Annexure 2**.

2.3 **Project Manager:** The agency shall undertake the survey work of embankments of Hooghly district and corresponding mapping in consultation with the Executive Engineer-II, Lower Damodar Irrigation Division who will act as Engineer-in-charge & Project Manager on behalf of I &W Department.

## 3. Notice by Service Provider to Employer

The second party, on the services reaching each stage of execution, issue a notice to the first party or the Project Manager nominated by the first party (who is responsible for supervising the Service Provider, administering the contract, certifying the payments due to the Service Provider, issuing and valuing variations to the contract, awarding extensions of time etc.), to visit the site for certification of stage completion. Within 15 days of the receipt of such notice, the first party or the Project Manager nominated by it, will ensure issue of stage completion certificate after due verification.

## 4. Completion Time

**The services should be completed in 3 (Three) months [90 days] from the date of this Agreement. In exceptional circumstances, the time period stated in this clause may be extended in writing by mutual consent of both the parties.**

5. If any of the compensation events mentioned below would prevent the services being completed by the intended completion date, the first party will decide on the intended completion date being extended by a suitable period:

- (a) The first party orders a delay for execution of the services on time.
- (b) Ground conditions are substantially more adverse than could reasonably have been assumed before issue of letter of acceptance and from information provided to second party or from visual inspection of the site.
- (c) Payments due to the second party are delayed without reason.
- (d) Certification for stage completion of the services is delayed unreasonably.

6. Any willful delay on the part of the second party in completing the services within the stipulated period will render him liable to pay liquidated damages. @ INR 0.05% of the contract value per day which will be deducted from payments due to him. The first party may cancel the contract and take recourse to such other action as deemed appropriate once the total amount of liquidated damages exceeds 5 % of the contract amount.

## **7. Duties and Responsibilities of the First Party**

7.1 The first party shall be responsible for providing regular and frequent supervision and guidance to the second party for carrying out the services as per description of services. This will include written guidelines and regular site visit of the authorized personnel of the first party, for checking quality of services to ensure that it is as per the norms.

7.2 The Project Manager or such other person as may be authorized by the first party shall hold meeting once in a fortnight where the second party or his representative will submit the latest information including progress report and difficulties if any, in the execution of the services. The whole team may jointly inspect the site on a particular day to take stock of activities.

7.3 The Project Manager shall record his observations/instructions at the time of his site visit. The second party will carry out the instructions and promptly rectify any deviations pointed out by the Project Manager. If the deviations are not rectified, within the time specified in the Project Manager's notice, the first party as well as the Project Manager nominated by it, may instruct stoppage or suspension of the services. It shall there upon be open to the first party or the Project Manager to have the deviations rectified at the cost of the second party.

## **8. Duties and Responsibilities of the Second Party**

8.1 The second party shall:

- (a) take up the services and arrange for its completion within the time period stipulated in Clause 2 ;
- (b) employ suitable manpower and equipment to carry out the services;
- (c) regularly supervise and monitor the progress of services;

- (d) abide by the technical suggestions/direction of supervisory personnel designated by the Employer;
- (e) be responsible for bringing any discrepancy to the notice of the representative of the first party and seek necessary clarification;
- (f) ensure that the service is carried out in accordance with specifications, drawings and within the total of the contract amount without any cost escalation;
- (g) keep the first party informed about the progress of services;
- (h) maintain necessary insurance against loss of equipment and property etc. or workman disability compensation claims of the personnel deployed on the services as well as third party claims.
- (i) pay all duties, taxes and other levies payable by service providers' agencies as per law under the contract (First party will effect deduction (TDS) from running bills in respect of such taxes as may be imposed under the law).

## **9. Variations / Extra Items**

The services shall be carried out by the second party in accordance with the approved description of services. However, if, on account of any other factors, variations are considered necessary, the following procedure shall be followed:

- (a) The second party shall provide the Project Manager with a quotation for carrying out the Variation when requested to do so by the Project Manager. The Project Manager shall assess the quotation, which shall be given within seven days of the request before the Variation is ordered.
- (b) If the quotation given by the second party is unreasonable, the Project Manager may order the Variation and make a change to the Contract Price which shall be based on Project Manager's own forecast of the effects of the Variation on the Service Provider's costs.
- (c) The second party shall not be entitled to additional payment for costs which could have been avoided by giving early warning.

## **10. Securities**

The Performance Security (either a Bank Guarantee in the format attached or Fixed Deposit/ Term Deposit Receipt from a Nationalized or Scheduled Bank in India) shall be provided to the Employer no later than the date specified in the Letter of Acceptance and shall be issued in an amount and form and by a bank or surety acceptable to the Employer. The Performance Security shall be valid beyond 45 days of the completion period.

## **11. Termination**

### **11.1 By the Employer**

The Employer may terminate this Contract, by not less than 15 days' written notice of termination to the Service Provider, to be given after the occurrence of any of the events specified below:

- (a) if the Service Provider does not remedy a failure in the performance of its obligations under the Contract, within 15 days after being notified or within any further period as the Employer may have subsequently approved in writing;
- (b) if the Service Provider become insolvent or bankrupt or goes into liquidation other than for a reconstruction or amalgamation;
- (c) if, as the result of Force Majeure (means an event which is beyond the reasonable control of a Party and which makes a Party's performance of its obligations under the Contract impossible or so impractical as to be considered impossible under the circumstances.), the Service Provider is unable to perform a material portion of the services for a period of not less than 30 days; or
- (d) if the Service Provider, in the judgment of the Employer has engaged in corrupt or fraudulent practices in competing for, then the Employer may after giving fourteen days written notice to the Service provider, terminate the contract and expel him from the site.

### **11.2 By the Service Provider**

The Service Provider may terminate this Contract, by not less than 15 days' written notice to the Employer, such notice to be given after the occurrence of any of the events specified below:

- (a) if the Employer fails to pay any monies due to the Service Provider pursuant to this Contract and not subject to dispute pursuant to Clause 10 within 45 days after receiving written notice from the Service Provider that such payment is overdue; or
- (b) if, as the result of Force Majeure, the Service Provider is unable to perform a material portion of the services for a period of not less than 30 days.

### **11.3 Suspension of Loan or Credit**

In the event that the World Bank suspends the loan or Credit to the Employer, from which part of the payments to the Service Provider are being made, the Employer is obligated to notify the Service Provider of such suspension within 7 days of having received the World Bank's suspension notice.

## **12 Payment upon Termination**

Upon termination of this Contract, the Employer shall make the following payments to the Service Provider:

- (a) payment for services satisfactorily performed less advances or other recoveries or any taxes to be deducted at source (TDS) as per applicable law, prior to the effective date of termination;
- (b) except in the case of termination pursuant to paragraphs above reimbursement of any reasonable cost incident to the prompt and orderly termination of the Contract, including the cost of the return travel of the Personnel.

### 13. Settlement of Disputes

**13.1 Amicable Settlement:** The Employer and Bidder shall use their best efforts to settle amicably all disputes arising out of or in connection with this Contract or its interpretation.

#### 13.2 Dispute Settlement

- (a) If any dispute arises between the Employer and the Service Provider in connection with, or arising out of, the Contract or the provision of the services, whether during carrying out the services or after their completion, the matter shall be referred to the Adjudicator within 14 days of the notification of disagreement of one party to the other.
- (b) The Adjudicator shall give a decision in writing within 28 days of receipt of a notification of a dispute.
- (c) The Adjudicator shall be paid by the hour at the rate specified above together with reimbursable expenses for vehicle hire, food and lodging, if required, as agreed in connection with the adjudication procedure, and the cost shall be divided equally between the Employer and the Bidder, whatever decision is reached by the Adjudicator. Either party may refer a decision of the Adjudicator to an Arbitrator within 28 days of the Adjudicator's written decision. If neither party refers the dispute to arbitration within the above 28 days, the Adjudicator's decision will be final and binding.
- (d) The arbitration shall be conducted in accordance with the Arbitration and Conciliation Act, 1996 and latest amendment.
- (e) Should the Adjudicator resign or die, or should the Employer and the Bidder agree that the Adjudicator is not functioning in accordance with the provisions of the Contract, a new Adjudicator will be jointly appointed by the Employer and the Bidder. In case of disagreement between the Employer and the Bidder, within 30 days, the Adjudicator shall be designated by the President of the Institution of Engineers, [State] State Centre at the request of either party, within 14 days of receipt of such request.
- (f) The place of Adjudicator /Arbitrator shall be \_\_\_\_\_
- (g) The Court of Jurisdiction shall be \_\_\_\_\_

### 14. Corrupt and Fraudulent Practices

The World Bank requires compliance with its policy in regard to corrupt and fraudulent practices. In further pursuance of this policy, Bidders shall permit and shall cause its agents (whether declared or not), sub-contractors, sub-consultants, service providers, or suppliers and any personnel thereof, to permit the Bank to inspect all accounts, records and other documents relating to any prequalification process, bid submission, and contract performance (in the case of award), and to have them audited by auditors appointed by the Bank.

The Format of Certificate (**Annexure I**) & Description of Services (**Annexure II**) are attached

Signed and delivered by Sri. \_\_\_\_\_ for and on behalf of the Service Provider



In the presence of the Witness:

i)

ii)

**SIGNATURE**

Signed and delivered by Sri \_\_\_\_\_ for and on  
behalf of the Employer.

In the presence of the Witness:

i)

ii)

**SIGNATURE**

## Annexure I

### FORMAT OF CERTIFICATE

Certified that the services up to ----- stage in respect of non-consulting services of ----- RFQ No. ----- have been executed satisfactorily in accordance with the terms and conditions of the agreement and as per approved specifications.

Signature  
Name & Designation

(Official address)

Place:

Date:

Office seal

## Annexure II

### DESCRIPTION OF SERVICES

#### **Description of services as follows:**

**i)**

**a)** Detailed field survey of embankment/ and or bank of river/khal by taking cross sections @ not exceeding 250 m c/c ( extending each cross section 10 m from - country side toe line of both side embankments /country side end point of both side banks) w.r.t. G.T.S. Bench Mark value.

**b)** Carrying out closed leveling from available nearest permanent GTS Bench Mark point up to present working locations for rivers/khals throughout as per direction of E.I.C. and providing all details with X,Y,Z co-ordinates using digital level instrument at appropriate places , raw data from digital level shall be submitted along with adjusted and unadjusted levels in tabular form & by using applicable Geo-Office software as per direction of Engineer-in-charge complete.

Digital leveling instrument to be used for the work shall have the minimum accuracy of order 0.30 mm per km (double run) with least count not more than 0.01 mm.

**ii)** Conducting in-situ field density test by common balance ,field moisture content test by rapid moisture meter, field permeability test by constant head method [ at an average depth of 1.5 mtr from top of embankment/bank ] @500 m c/c distance along both embankments and/ or banks and submission of report after getting them certified by reputed Govt. organization/institute as per direction of Engineer-in-charge.

**iii)** Collection of undisturbed soil samples @1000 m c/c distance along both embankments and/ or banks from a suitable depth from top of embankment/bank & carriage of those samples with proper labeling of collection locations for assessment of different geotechnical and soil properties to River Research Institute , Haringhata, West Bengl , as per direction of Engineer-in-charge.

**iv)** Construction of Bench Mark pillars as per enclosed drawing and specification. This Bench mark pillars are to be constructed at suitable locations along rivers / khals as per direction of E.I.C. A topographic map showing location of all such B.M. pillars with Geo-reference and corresponding G.T.S. B.M. values is to be submitted [Both soft & Hard copy ] during submission of report. All those B.M. pillars are to be properly coloured and marked as per direction of Engineer-in-charge.

**v)** Submission of report comprising detail drawings [both soft copy & hard copy] in the form of index map, topographic site plan showing all important features, cross sections & long sections of rivers/khals in suitable scale and relevant photographs etc. as per direction of Engineer-in-charge.

a) Apart from the hard copy of report & drawings, soft copies of all survey data are to be submitted in Excel, Arc-GIS and AutoCAD format for records and further analysis.

b) A .DWG & .KMZ/.KML file of the detailed topographic survey of the embankment/ bank shall be made from the survey data such that the layer can be visualized in Google Earth/Arc GIS Earth.

# NOTICE TO PROCEED

*[letterhead paper of the Employer]*

\_\_\_\_\_ (date)

To

\_\_\_\_\_ (name and address of the Service Provider)

\_\_\_\_\_

\_\_\_\_\_

Pursuant to your furnishing the requisite security as stipulated in RFQ Clause12, and as stated in letter of acceptance and signing of the contract agreement for the non-consulting services of \_\_\_\_\_ @ a Contract Price of INR \_\_\_\_\_, you are hereby instructed to proceed with the execution of the said services in accordance with the contract documents.

Authorized Signature:

Name and Title of Signatory:

Name of Agency:

Attachment: Contract Agreement

# **BANK GUARANTEE FOR ADVANCE PAYMENT**

***(To be given from a nationalized or scheduled bank in India)***

To:

*The Executive Engine  
Burdwan Investigation & Planning Division,  
I&WD, Govt. of West Bengal. Purta Bhawan, 3rd Floor,  
PurbaBurdwan-713103  
West Bengal*

**Name of work : Survey of embankments in Hooghly District and corresponding mapping under NHP of I&W Deptt., GoWB. [Phase-I]**

In accordance with the provisions of the Contract Agreement, Sub-Clause 2.1(“**Payments under the Contract**”) of the above-mentioned Contract, *[name and address of Service Provider]* (hereinafter called “the Service Provider”) shall deposit with *The Executive Engineer, Burdwan Investigation & Planning Division, I & WD, Govt. of West Bengal* a Bank Guarantee to guarantee his proper and faithful performance under the said Clause of the Contract in an amount of *[amount of Guarantee] [amount in words]*

We, the *[Bank or Financial Institution]*, as instructed by the Service Provider, agree unconditionally and irrevocably to guarantee as primary obligator and not as Surety merely, the payment to *[name of Employer]* on his first demand without whatsoever right of objection on our part and without his first claim to the Service Provider, in the amount not exceeding *[amount of Guarantee] [amount in words]*

We further agree that no change or addition to or other modification of the terms of the Contract or of Services to be performed there under or of any of the Contract documents which may be made between *[name of Employer]* and the Service Provider, shall in any way release us from any liability under this Guarantee, and we hereby waive notice of any such change, addition, or modification.

This Guarantee shall remain valid and in full effect from the date of the advance payment under the Contract until *The Executive Engineer, Burdwan Investigation & Planning Division, I&WD, Govt. of West Bengal* receives full repayment of the same amount from the Service Provider.

Yours truly,

Signature and seal:

Name of Bank/Financial Institution:

Address:

Date:

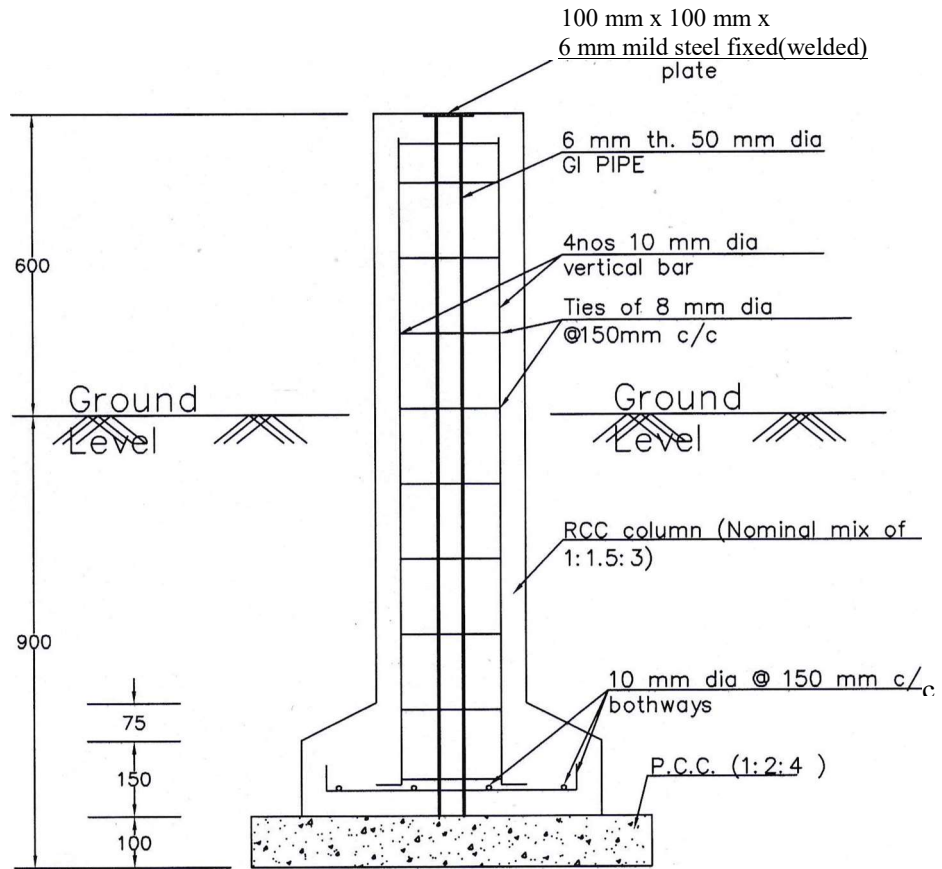

**SECTIONAL ELEVATION**

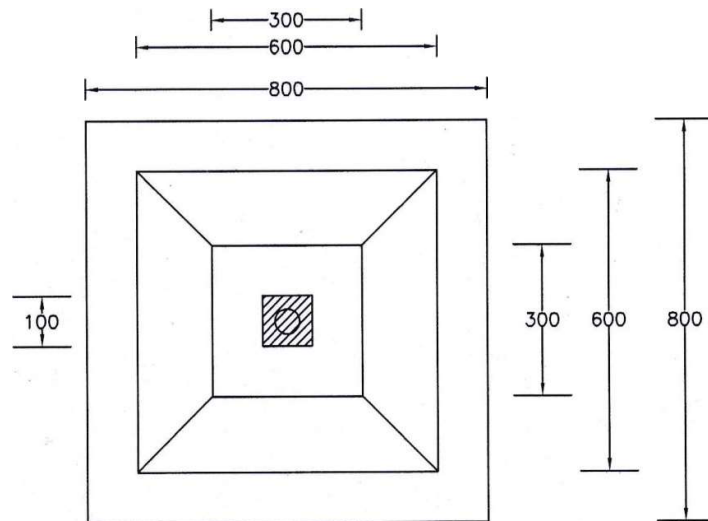

**PLAN**

Signature of Quotationer  
(With Stamp)

Sd/-  
Executive Engineer  
Burdwan Investigation & Planning Division