



Government of West Bengal
Irrigation & Waterways Department
National Hydrology Project
NH-2, PurtaBhawan, 3rdFloor, PurbaBurdwan-713103
Tel:+91342-2646799 Fax:+91342-2646799
Email: eebipd2012@gmail.com / bengalsw@gmail.com

NATIONAL COMPETITIVE BIDDING FOR
(Two-Envelope Bidding Process with e-Procurement)

SUPPLY, INSTALLATION, TESTING, COMMISSIONING AND
MAINTENANCE OF REAL TIME DATA ACQUISITION SYSTEM (RTDAS)
WITH TELEMETRY OF IRRIGATION AND WATERWAYS DEPARTMENT
WEST BENGAL UNDER NATIONAL HYDROLOGY PROJECT (NHP) AND
INTEGRATE WITH DATACENTER LOCATED AT KOLKATA

<i>Bid Reference</i>	WBIW/NHP/RTDAS/IFB-01/19-20
<i>Procurement Plan Ref. no</i>	Package No. NHP-2018-19-WBSW-995987-GO-NCB-DE
Bid documents	Can be downloaded from Website https://wbenders.gov.in .
Bid Document Publish date & time	06/06/2019; 11:00 HRS
Bid Document Download Starting date &	07/06/2019; 10:00 HRS
Document Download Closing date & time	08/07/2019; 15:30 HRS
Bid Clarification Starting date & time	10/06/2019; 10:00 HRS
Bid Clarification Closing date & time	17/06/2019; 15:30 HRS
Pre Bid Meeting date &time	20/06/2019; 11:30 HRS
Online Bid Submission Starting date & time	27/06/2019; 10:00 HRS
Online Bid Submission Closing date & time	09/07/2019; 15:00 HRS
Last date and time of Receipt of relevant document as mentioned (IFB) by Speed Post/Courier/by hand.	09/07/2019; 15:00 HRS
Date& Time of Opening of Technical Bid	09/07/2019; 15:30 HRS

Address for Communication	The Executive Engineer Burdwan Investigation & Planning Division Purta Bhawan, 3 rd Floor Burdwan-713103, West Bengal OR Superintending Engineer Investigation & Planning Circle II Irrigation & Waterways Directorate Jalasampad Bhavan Salt Lake, Kolkata 91
---------------------------	--

SECTION I: INVITATION FOR BIDS (IFB)

NATIONAL COMPETITIVE BIDDING FOR
SUPPLY, INSTALLATION, TESTING, COMMISSIONING AND
MAINTENANCE OF REAL TIME DATA ACQUISITION SYSTEM (RTDAS)
WITH TELEMTRY OF IRRIGATION AND WATERWAYS DEPARTMENT
WEST BENGAL UNDER NATIONAL HYDROLOGY PROJECT (NHP) AND
INTEGRATE WITH DATACENTER LOCATED AT KOLKATA
(Two-Envelope Bidding Process with e-Procurement)

INVITATION FOR BIDS (IFB)
E-Procurement Notice

Memo No: 217/NHP-02/02

Date: **06/06/19**

Loan No. : 8725IN

IFB No. : WBIW/NHP/RTDAS/IFB-01/19-20

Procurement Plan Ref. No.: NHP-2018-19-WBSW-995987-GO-NCB-DE

1. This Invitation for Bid follows the General Procurement Notice for this Project that appeared in Development Business on 9th March, 2017.
2. The Government of India has received financing from the World Bank towards the cost of National Hydrology Project and it is intended that part of the proceeds will be applied to eligible payments under the Contract¹ for which this invitation for bids is issued.
3. The Executive Engineer Burdwan Investigating and Planning Division, Irrigation and Waterways Department West Bengal now invites online bids from eligible bidders for Supply Installation Testing Commissioning and Maintenance of Real Time Data Acquisition System (RTDAS) with telemetry of Irrigation and Waterways Department West Bengal Under National Hydrology Project (NHP) And Integrate with Data Center located at Kolkata, West Bengal
4. Bidding will be conducted through the National Competitive Bidding (NCB) procedures agreed with World Bank. The bidding is open to all eligible bidders as defined in the Bank's Procurement Guidelines. In addition, please refer to paragraphs 1.6 and 1.7 of the Guidelines setting forth the World Bank's policy on conflict of interest.
5. Bidding documents are available free of cost online on <https://wbtenders.gov.in>. Bidders will be required to register in the website, which is free of cost. The bidder would be responsible for ensuring that any addenda available on the website is also downloaded and incorporated.

<i>Bid Reference</i>	WBIW/NHP/RTDAS/IFB-01/19-20
<i>Procurement Plan Ref. no</i>	Package No. NHP-2018-19-WBSW-995987-GO-NCB-DE
Bid documents	Can be downloaded from Website https://wbtenders.gov.in .
Price of Bid Document	Free of Cost

Bid Document Download Starting date & time	07/06/2019; 10:00 HRS
Document Download Closing date & time	08/07/2019; 15:30 HRS
Bid Clarification Starting date & time	10/06/2019; 10:00 HRS
Bid Clarification Closing date & time	17/06/2019; 15:30 HRS
Pre Bid Meeting date&time	20/06/2019; 11:30 HRS
Online Bid Submission Starting date & time	27/06/2019; 10:00 HRS
Online Bid Submission Closing date & time	09/07/2019; 15:00 HRS
Last date and time of Receipt of relevant document as mentioned (IFB) by Speed Post/Courier/by hand.	09/07/2019; 15:00 HRS
Date & Time of Opening of Technical Bid	09/07/2019; 15:30 HRS

6. For submission of the bids, the bidder is required to have Digital Signature Certificate (DSC) from one of the authorized Certifying Authorities, authorised by Government of India for issuing DSC. Aspiring bidders who have not obtained the user ID and password for participating in e-procurement in this Project, may obtain the same from the website: <https://wbtenders.gov.in>
7. Bids security of the amount specified in the bidding document, drawn in favour of Executive Engineer Burdwan Investigating and Planning Division, Irrigation and Waterways Department West Bengal must be submitted as per the procedure described in paragraph 8 below. The Bid security will have to be in any one of the forms as specified in the bidding document and shall have to be valid for 45 days beyond the validity of the bid. Bids must be submitted online on <https://wbtenders.gov.in>. on or before the date and time for receipt of bids, and the 'Technical Part' of bids will be opened online on the specified time and date for opening of bids, as given above. The "Financial Part" shall remain unopened in the e-procurement system until the second public Bid opening for the financial part. Any bid or modifications to bid (including discount) received outside e-procurement system will not be considered. If the office happens to be closed on the date of opening of the bids as specified, the bids will be opened on the next working day at the same time. The electronic bidding system would not allow any late submission of bids.
8. The bidders are required to submit (a) registration on e-procurement website (if not previously registered);(b) original bid security in approved form; and (c) original affidavit regarding correctness of information furnished with bid document with Executive Engineer Burdwan Investigating and Planning Division, Irrigation and Waterways Department West Bengal before the opening of the technical part of the Bid given above, either by registered post/speed post/courier or by hand, failing which the bids will be declared non-responsive and will not be opened.

9. Other details can be seen in the bidding document. The Purchaser shall not be held liable for any delays due to system failure beyond its control. Even though the system will attempt to notify the bidders of any bid updates, the Purchaser shall not be liable for any information not received by the bidder. It is the bidders' responsibility to verify the website for the latest information related to this bid.

The Executive Engineer
Burdwan Investigation & Planning Division
Irrigation & Waterways Directorate Govt. of West Bengal
PurtaBhawan, 3rd Floor Purba Burdwan-713103, West Bengal
e-mail: eebipd2012@gmail.com

TABLE OF CONTENTS

PART 1 – BIDDING PROCEDURES	7
SECTION I - INSTRUCTIONS TO BIDDERS [ITB].....	8
SECTION II - BIDDING DATA SHEET	34
SECTION III - EVALUATION AND QUALIFICATION CRITERIA.....	
SECTION IV - BIDDING FORMS.....	
SECTION V. – ELIGIBLE COUNTRIES.....	822
SECTION VI. BANK POLICY - CORRUPT AND FRAUDULENT PRACTICES	8383
PART 2 - SUPPLY REQUIREMENTS	87
SECTION VII – SCHEDULE OF REQUIREMENTS	88
PART 3 – CONTRACT.....	195195
SECTION VIII – GENERAL CONDITIONS OF CONTRACT	196196
SECTION IX. SPECIAL CONDITIONS OF CONTRACT.....	216216
SECTION X – CONTRACT FORMS.....	230230

PART 1 – BIDDING PROCEDURES

SECTION I - INSTRUCTIONS TO BIDDERS [ITB]

Section I. Instructions to Bidders

Table of Clauses

A. GENERAL	11
1. SCOPE OF BID.....	11
2. SOURCE OF FUNDS	11
3. CORRUPT & FRAUDULENT PRACTICES	11
4. ELIGIBLE BIDDERS	12
5. ELIGIBLE GOODS AND RELATED SERVICES	14
B. CONTENTS OF BIDDING DOCUMENT	14
6. SECTIONS OF BIDDING DOCUMENTS	14
7. CLARIFICATION OF BIDDING DOCUMENTS	15
8. AMENDMENT OF BIDDING DOCUMENTS.....	15
C. PREPARATION OF BIDS	16
9. COST OF BIDDING	16
10. LANGUAGE OF BID.....	16
11. DOCUMENTS COMPRISING THE BID.....	16
12. PROCESS OF BID SUBMISSION	17
13. ALTERNATIVE BIDS	18
14. BID PRICES AND DISCOUNTS.....	18
15. CURRENCIES OF BID& PAYMENT	20
16. DOCUMENTS ESTABLISHING THE ELIGIBILITY AND CONFORMITY OF THE GOODS AND RELATED SERVICES.....	20
17. DOCUMENTS ESTABLISHING THE ELIGIBILITY & QUALIFICATIONS OF THE BIDDER	21
18. PERIOD OF VALIDITY OF BIDS	21
19. BID SECURITY	23
20. FORMAT AND SIGNING OF BID	24
D. ONLINE SUBMISSION OF BIDS	24
21. PREPARATION OF BIDS	24
22. DEADLINE FOR SUBMISSION OF BIDS	25
23. LATE BIDS	25
24. WITHDRAWAL, SUBSTITUTION, AND MODIFICATION OF BIDS	25
25. PUBLIC OPENING OF TECHNICAL PARTS OF BIDS	26
E. EVALUATION OF BIDS – GENERAL PROVISIONS	27
26. CONFIDENTIALITY	27
27. CLARIFICATION OF BIDS	27
28. DEVIATIONS, RESERVATIONS, OMISSIONS	27
29. NONCONFORMITIES, ERRORS AND OMISSIONS	27
30. EVALUATION OF TECHNICAL PARTS	28
31. DETERMINATION OF RESPONSIVENESS.....	28
32. QUALIFICATION OF THE BIDDERS.....	29
33. PUBLIC OPENING OF FINANCIAL PARTS	29
34. EVALUATION OF FINANCIAL PART.....	
35. CORRECTION OF ARITHMETICAL ERRORS	31

36	CONVERSION TO SINGLE CURRENCY	32
37	MARGIN OF DOMESTIC PREFERENCE.....	
38	COMPARISON OF FINANCIAL PARTS	32
39	PURCHASER’S RIGHT TO ACCEPT ANY BID, AND TO REJECT ANY OR ALL BIDS	32
F. AWARD OF CONTRACT	32
40	AWARD CRITERIA	32
41	PURCHASER’S RIGHT TO VARY QUANTITIES AT TIME OF AWARD	32
42	NOTIFICATION OF AWARD	32
	PUBLICATION OF AWARD.....	32
	RECOURSE TO UNSUCCESSFUL BIDDERS	33
43	SIGNING OF CONTRACT.....	33
44	PERFORMANCE SECURITY	33

Section I. Instructions to Bidders

A. General

1. **Scope of Bid**
 - 1.1 The Purchaser **indicated in the Bidding Data Sheet (BDS)**, issues these Bidding Documents for the supply of Goods and Related Services incidental thereto as specified in Section VII, Schedule of Requirements. The name, identification and number of lots (Contracts) of this National Competitive Bidding (NCB) procurement are **specified in the BDS**.
 - 1.2 Throughout these Bidding Documents:
 - (a) the term “in writing” means communicated in written form (e.g. by mail, e-mail, fax, telex, including if **specified in the BDS**, distributed or received through the electronic-procurement system used by the Employer) with proof of receipt;
 - (b) if the context so requires, “singular” means “plural” and vice versa; and
 - (c) “day” means calendar day.
2. **Source of Funds**
 - 2.1 The Government of India (hereinafter called “Borrower”) **specified in the BDS** has applied for or received financing (hereinafter called “funds”) from the International Bank for Reconstruction and Development or the International Development Association (hereinafter called “the Bank”) in an amount **specified in BDS** toward the project **named in the BDS**. The Borrower intends to apply a portion of the funds to eligible payments under the Contract for which these Bidding Documents are issued.
 - 2.2 Payment by the Bank will be made only at the request of the Borrower and upon approval by the Bank in accordance with the terms and conditions of the Loan (or other financing) Agreement. The Loan (or other financing) Agreement prohibits a withdrawal from the loan or other financing) account for the purpose of any payment to persons or entities, or for any import of goods, if such payment or import, to the knowledge of the Bank, is prohibited by decision of the United Nations Security Council taken under Chapter VII of the Charter of the United Nations. No party other than the Borrower shall derive any rights from the Loan (or other financing) Agreement or have any claim to the funds.
3. **Corrupt & Fraudulent Practices**
 - 3.1 The Bank requires compliance with its policy in regard to corrupt and fraudulent practices as set forth in Section VI.

3.2 In further pursuance of this policy, Bidders shall permit and shall cause its agents (whether declared or not), sub-Contractors, sub-consultants, service providers or suppliers and to permit the Bank to inspect all accounts, records and other documents relating to the submission of the application, bid submission (in case prequalified), and Contract performance (in the case of award), and to have them audited by auditors appointed by the Bank.

4. Eligible Bidders

4.1 A Bidder may be a firm that is a private entity, or a government owned entity subject to ITB 4.5.

4.2 A Bidder shall not have a conflict of interest. Any Bidder found to have a conflict of interest shall be disqualified. A Bidder may be considered to have a conflict of interest for the purpose of this bidding process, if the Bidder:

- a. directly or indirectly controls, is controlled by or is under common control with another Bidder; or
- b. receives or has received any direct or indirect subsidy from another Bidder; or
- c. has the same legal representative as another Bidder; or
- d. has a relationship with another Bidder, directly or through common third parties, that puts it in a position to influence the bid of another Bidder, or influence the decisions of the Purchaser regarding this bidding process; or
- e. participates in more than one bid in this bidding process. Participation by a Bidder in more than one Bid will result in the disqualification of all Bids in which such Bidder is involved. However, this does not limit the inclusion of the same Sub-Contractor in more than one bid; or
- f. any of its affiliates participated as a consultant in the preparation of the design or technical specifications of the goods/equipment that are the subject of the bid; or
- g. any of its affiliates has been hired (or is proposed to be hired) by the Purchaser or Borrower for the Contract implementation; or
- h. would be providing goods, works, or non-consulting services resulting from or directly related to consulting services for the preparation or implementation of the project specified in the BDS ITB 2.1 that it provided or were provided by any of its affiliate that directly or indirectly controls, is controlled by, or is under common control with that firm; or
- i. has a close business or family relationship with a professional staff of the Borrower (or of the project implementing agency, or of a recipient of a part of the loan) who: (i) are directly or indirectly involved in the preparation of the bidding documents or specifications of the Contract, and/or the bid evaluation process of such Contract; or (ii) would be involved in the implementation or supervision of such Contract unless the conflict stemming from

such relationship has been resolved in a manner acceptable to the Bank throughout the procurement process and execution of the Contract.

- 4.3 A Bidder may have the nationality of any country, subject to the restrictions pursuant to ITB 4.7. A Bidder shall be deemed to have the nationality of a country if the Bidder is constituted, incorporated or registered in and operates in conformity with the provisions of the laws of that country, as evidenced by its articles of incorporation (or equivalent documents of constitution or association) and its registration documents, as the case may be. This criterion also shall apply to the determination of the nationality of proposed sub-Contractors or sub-consultants for any part of the Contract including related Services.
- 4.4 A Bidder that has been sanctioned by the Bank in accordance with the above ITB 3.1, including in accordance with the Bank's Guidelines on Preventing and Combating Corruption in Projects Financed by IBRD Loans and IDA Credits and Grants ("Anti-Corruption Guidelines"), shall be ineligible to be prequalified for, bid for, or be awarded a Bank-financed Contract or benefit from a Bank-financed Contract, financially or otherwise, during such period of time as the Bank shall have determined. The list of debarred firms and individuals is available at the electronic address **specified in the BDS.**
- 4.5 Bidders that are Government-owned enterprises or institutions in the Purchaser's Country may participate only if they can establish that they (i) are legally and financially autonomous (ii) operate under commercial law, and (iii) are not dependent agencies of the Purchaser. To be eligible, a government-owned enterprise or institution shall establish to the Bank's satisfaction, through all relevant documents, including its Charter and other information the Bank may request, that it: (i) is a legal entity separate from the government (ii) does not currently receive substantial subsidies or budget support; (iii) operates like any commercial enterprise, and, inter alia, is not obliged to pass on its surplus to the government, can acquire rights and liabilities, borrow funds and be liable for repayment of its debts, and can be declared bankrupt; and (iv) is not bidding for a Contract to be awarded by the department or agency of the government which under their applicable laws or regulations is the reporting or supervisory authority of the enterprise or has the ability to exercise influence or control over the enterprise or institution.
- 4.6 A Bidder shall not be under suspension from bidding by the Purchaser as the result of the operation of a Bid-Securing Declaration.

4.7 Firms and individuals may be ineligible if so indicated in Section V and (a) as a matter of law or official regulations, the Borrower's country prohibits commercial relations with that country, provided that the Bank is satisfied that such exclusion does not preclude effective competition for the supply of goods or the Contracting of works or services required; or (b) by an act of compliance with a decision of the United Nations Security Council taken under Chapter VII of the Charter of the United Nations, the Borrower's country prohibits any import of goods or Contracting of works or services from that country, or any payments to any country, person, or entity in that country.

4.8 A bidder shall provide such evidence of eligibility satisfactory to the Purchaser, as the Purchaser shall reasonably request.

4.9 Not used.

5. Eligible Goods and Related Services

5.1 All the Goods and Related Services to be supplied under the Contract and financed by the Bank may have their origin in any country in accordance with Section V, Eligible Countries.

5.2 For purposes of this Clause, the term "goods" includes commodities, raw material, machinery, equipment, and industrial plants; and "related services" includes services such as insurance, installation, training, and initial maintenance.

5.3 The term "origin" means the country where the goods have been mined, grown, cultivated, produced, manufactured or processed; or, through manufacture, processing, or assembly, another commercially recognized article results that differs substantially in its basic characteristics from its components.

B. Contents of Bidding Document

6. Sections of Bidding Documents

6.1 The Bidding Documents consist of Parts 1, 2, and 3, which include all the Sections indicated below, and should be read in conjunction with any Addendum issued in accordance with ITB Clause 8.

PART 1 Bidding Procedures

- Section I. Instructions to Bidders (ITB)
- Section II. Bidding Data Sheet (BDS)
- Section III. Evaluation and Qualification Criteria
- Section IV. Bidding Forms
- Section V. Eligible Countries

- Section VI Bank Policy-Corrupt and Fraudulent Practices

PART 2 Supply Requirements

- Section VII. Schedule of Requirements

PART 3 Contract

- Section VIII. General Conditions of Contract (GCC)
- Section IX. Special Conditions of Contract (SCC)
- Section X. Contract Forms

6.2 The Invitation for Bids issued by the Purchaser is not part of the Bidding Document.

6.3 Unless obtained directly from the Purchaser, the Purchaser is not responsible for the completeness of the document, responses to requests for clarification, minutes of pre-bid meeting (if any), or Addenda to the Bidding Document in accordance with ITB 8. In case of any contradiction, documents obtained directly from the Purchaser shall prevail.

6.4 The Bidder is expected to examine all instructions, forms, terms, and specifications in the Bidding Documents and to furnish with its Bid all information or documentation as is required by the Bidding Documents.

7. Clarification of Bidding Documents

7.1 The electronic bidding system **specified in the BDS** provides for online clarifications. A prospective Bidder requiring any clarification on the Bidding Documents may notify the Purchaser online. Clarifications requested through any other mode shall not be considered by the Purchaser. The Purchaser will respond to any request for clarification, provided that such request is received no later than fifteen (15) days prior to the deadline for submission of bids. Description of clarification sought and the response of the Purchaser shall be uploaded for information of all Bidders without identifying the source of request for clarification. Should the Purchaser deem it necessary to amend the Bidding Documents as a result of a clarification, it shall do so following the procedure under ITB Clause 8 and ITB Sub-Clause 22.2. It is the bidder's responsibility to check on the e-procurement system, for any addendum/ amendment/ corrigendum to the bidding document.

8. Amendment of Bidding Documents

8.1 At any time prior to the deadline for submission of bids, the Purchaser may amend the Bidding Documents by issuing addendum. The addendum will appear on the e-procurement system under "Latest Corrigendum" and email notification is also

automatically sent to those bidders who have started working on the tender, or as **otherwise specified in BDS**.

- 8.2 Any addendum thus issued shall be part of the Bidding Documents and shall be deemed to have been communicated to all the bidders.
- 8.3 To give prospective Bidders reasonable time in which to take an addendum into account in preparing their bids, the Purchaser may, at its discretion, extend the deadline for the submission of bids, pursuant to ITB Sub-Clause 22.2

C. Preparation of Bids

- 9. Cost of Bidding** 9.1 The Bidder shall bear all costs associated with the preparation and submission of its bid, and the Purchaser shall not be responsible or liable for those costs, regardless of the conduct or outcome of the bidding process.
- 10. Language of Bid** 10.1 The Bid, as well as all correspondence and documents relating to the bid exchanged by the Bidder and the Purchaser, shall be written in English language. Supporting documents and printed literature that are part of the Bid may be in another language provided they are accompanied by an accurate translation of the relevant passages into English language, in which case, for purposes of interpretation of the Bid, such translation shall govern.
- 11. Documents Comprising the Bid** 11.1 The Bid shall comprise two Parts, namely the Technical Part and the Financial Part. These two Parts shall be submitted simultaneously.
- 11.2 **The Technical Part** shall contain the following:
- (a) Letter of Bid – Technical Part, in accordance with ITB Clause 12;
 - (b) Bid Security, in accordance with ITB Clause 19.1, if required;
 - (c) Alternative bids– Technical Part, if permissible, in accordance with ITB 13, the Technical Part of any Alternative Bid;
 - (d) written confirmation authorizing the signatory of the Bid to commit the Bidder, in accordance with ITB Clause 20.2;
 - (e) documentary evidence in accordance with ITB Clause 17 establishing the Bidder’s qualifications to perform the Contract if its bid is accepted;
 - (f) documentary evidence in accordance with ITB 17

establishing the Bidder's eligibility to bid;

- (g) documentary evidence in accordance with ITB Clause 16, that the Goods and Related Services to be supplied by the Bidder are of eligible origin;
- (h) documentary evidence in accordance with ITB Clauses 16, that the Goods and Related Services conform to the Bidding Documents;
- (i) Manufacturer's authorization form; and
- (j) any other document **required in the BDS.**

11.3 The **Financial Part** shall contain the following:

- (a) Letter of Bid – Financial Part: prepared in accordance with ITB 12 and ITB 14;
- (b) Price Schedules: completed prepared in accordance with ITB 12 and ITB 14;
- (c) Alternative Bid - Financial Part; if permissible in accordance with ITB 13, the Financial Part of any Alternative Bid; and
- (d) any other document **required in the BDS.**

11.4 The Technical Part shall not include any financial information related to the Bid price. Where material financial information related to the Bid price is contained in the Technical Part, the Bid shall be declared non-responsive.

11.5 The Bidder shall furnish in the Letter of Bid, information on commissions and gratuities, if any, paid or to be paid to agents or any other party relating to this Bid.

12. Process of Bid Submission

12.1 The Letter of Bid – Technical Part, Letter of Bid – Financial Part, and Price Schedules shall be prepared using the relevant forms furnished in Section IV, Bidding Forms. The forms must be completed without any alterations to the text, and no substitutes shall be accepted except as provided under ITB 20.2. All blank spaces shall be filled in with the information requested.

12.2 Entire Bid including the Letter of Bid and filled-up Price Schedules shall be submitted online on e-procurement system specified in ITB 7.1. Details and process of online submission of the tender and relevant documents are given in the website mentioned above. Scanned copies of documents listed in clauses 11 and 12.3 should also be uploaded on this website.

12.3 **Submission of Original Documents:** The bidders are required to separately submit (i) original demand drafts towards the cost of bid document and registration on e-procurement website (if not previously registered) (as per RFB); (ii) original bid security

in approved form; and (iii) original affidavit regarding correctness of information furnished with bid document, with the office **specified in the BDS**, before the opening of the technical part of the Bid, either by registered/speed post/courier or by hand, failing which the bids will be declared non-responsive and will not be opened. Hard copy of rest of the bid is not to be submitted.

- 13. Alternative Bids** 13.1 Unless otherwise **specified in the BDS**, alternative bids shall not be considered.
- 14. Bid Prices and Discounts**
- 14.1 The prices and discounts quoted by the Bidder in the Letter of Bid – Financial Part and in the Price Schedules shall conform to the requirements specified below.
- 14.2 All lots (Contracts) and items must be listed and priced separately in the Price Schedules.
- 14.3 The price to be quoted in the Letter of Bid – Financial Part, in accordance with ITB 12.1, shall be the total price of the bid, excluding any discounts offered.
- 14.4 The Bidder shall quote any discounts and indicate the methodology for their application in the Letter of Bid – Financial Part in accordance with ITB 12.1.
- 14.5 Prices quoted by the Bidder shall be fixed during the Bidder's performance of the Contract and not subject to variation on any account, **unless otherwise specified in the BDS**. A bid submitted with an adjustable price quotation shall be treated as nonresponsive and shall be rejected, pursuant to ITB 31. However, if in accordance with the BDS, prices quoted by the Bidder shall be subject to adjustment during the performance of the Contract, a bid submitted with a fixed price quotation shall not be rejected, but the price adjustment shall be treated as zero.
- 14.6 If so specified in ITB 1.1, bids are being invited for individual lots (Contracts) or for any combination of lots (packages). Unless otherwise **specified in the BDS**, prices quoted shall correspond to 100 % of the items specified for each lot and to 100% of the quantities specified for each item of a lot. Bidders wishing to offer discounts for the award of more than one Contract shall specify in their bid the price reductions applicable to each package, or alternatively, to individual Contracts within the package. Discounts shall be submitted in accordance with ITB 14.4 provided the bids for all lots (Contracts) are submitted and opened at the same time.
- 14.7 The terms EXW and other similar terms shall be governed by the rules prescribed in the current edition of Incoterms, published by The International Chamber of Commerce, **as specified in**

theBDS.

14.8 Prices shall be quoted as specified in the Price Schedule included in Section IV, Bidding Forms. The dis-aggregation of price components is required solely for the purpose of facilitating the comparison of bids by the Purchaser. This shall not in any way limit the Purchaser's right to Contract on any of the terms offered. In quoting prices, the Bidder shall be free to use transportation through carriers registered in any eligible country, in accordance with Section V Eligible Countries. Similarly, the Bidder may obtain insurance services from any eligible country in accordance with Section V Eligible Countries. Prices shall be entered in the following manner:

(a) **For Goods:**

- (i) the price of the Goods quoted EXW (ex-works, ex-factory, ex-warehouse, ex-showroom, or off-the-shelf, as applicable), including all duties, and GST and other taxes already paid or payable on the components and raw material used in the manufacture or assembly of the Goods;
- (ii) any GST and other taxes which will be payable in India on the Goods, if the Contract is awarded to the Bidder; and
- (iii) the price for inland transportation, insurance, and other local services required to convey the Goods to their final destination (Project Site) **specified in theBDS.**

(b) for the Related Services, other than inland transportation and other services required to convey the Goods to their final destination, whenever such Related Services are specified in the Schedule of Requirements:

- (i) the price of each item comprising the Related Services (inclusive of any applicable taxes).

14.9 Deemed Export Benefits

Bidders may like to ascertain availability of tax/duty exemption benefits, available for Contracts financed under World Bank Credits/ Loans. They are solely responsible for obtaining such benefits, which they have considered in their bid and in case of failure to receive such benefits for reasons whatsoever, the Purchaser will not compensate the bidder.

Where the bidder has quoted taking into account such benefits, it must give all information required for issue of necessary

Certificates in terms of the Government of India's relevant Notification along with its bid as per form stipulated in Section IV Bidding Forms. Where the Purchaser issues such Certificates, such taxes and duties will not be reimbursed separately.

If the Bidder has considered the Deemed Export Benefits in its bid, the Bidder shall confirm and certify that the Purchaser will not be required to undertake any responsibilities of the deemed export scheme or the benefits available during Contract execution except issuing the required certificates. Bids which do not conform to this provision or any condition by the Bidder which makes the bid subject to availability of deemed export benefits or compensation on withdrawal of or any variations in the deemed export benefits scheme will make the bid non responsive and hence liable to rejection.

15. Currencies of Bid & Payment

15.1 The Bidder shall quote the Price in Indian Rupees only.

16. Documents Establishing the Eligibility and conformity of the Goods and Related Services

16.1 To establish the eligibility of the Goods and Related Services in accordance with ITB Clause 5, Bidders shall complete the country of origin declarations in the Price Schedule Forms, included in Section IV, Bidding Forms.

16.2 To establish the conformity of the Goods and Related Services to the Bidding Documents, the Bidder shall furnish as part of its Bid the documentary evidence that the Goods conform to the technical specifications and standards specified in Section VII, Schedule of Requirements.

16.3 The documentary evidence may be in the form of literature, drawings or data, and shall consist of a detailed item by item description of the essential technical and performance characteristics of the Goods and Related Services, demonstrating substantial responsiveness of the Goods and Related Services to the technical specification, and if applicable, a statement of deviations and exceptions to the provisions of the Section VII Schedule of Requirements.

16.4 The Bidder shall also furnish a list giving full particulars, including available sources and current prices of spare parts, special tools, etc., necessary for the proper and continuing functioning of the Goods during the period **specified in the BDS** following commencement of the use of the goods by the

Purchaser.

16.5 Standards for workmanship, process, material, and equipment, as well as references to brand names or catalogue numbers specified by the Purchaser in the Schedule of Requirements, are intended to be descriptive only and not restrictive. The Bidder may offer other standards of quality, brand names, and/or catalogue numbers, provided that it demonstrates, to the Purchaser's satisfaction, that the substitutions ensure substantial equivalence or are superior to those specified in the Section VII Schedule of Requirements.

**17. Documents
Establishing the
Eligibility
& Qualifications
of the Bidder**

17.1 To establish Bidder's eligibility in accordance with ITB 4, Bidders shall complete the Letter of Bid – Technical Part, included in Section IV, Bidding Forms.

17.2 The documentary evidence of the Bidder's qualifications to perform the Contract if its bid is accepted shall establish to the Purchaser's satisfaction:

(a) that the Bidder meets each of the qualification criterion Criteria specified in Section III, Evaluation and Qualification;

(b) (i) that, if **required in theBDS**, a Bidder that does not manufacture or produce the Goods it offers to supply shall submit the Manufacturer's Authorization using the form included in Section IV, Bidding Forms to demonstrate that it has been duly authorized by the manufacturer or producer of the Goods to supply these Goods in the Purchaser's Country;

(ii) Supplies for any particular item in each schedule of the bid should be from one manufacturer only. Bids from agents offering supplies from different manufacturers for the same item of the schedule in the bid will be treated as non-responsive.

(iii) that, if **required in theBDS**, the Bidder is or will be (if awarded the Contract) represented by an Agent in the country equipped and able to carry out the Supplier's maintenance, repair and spare parts-stocking obligations prescribed in the Conditions of Contract and/or Technical Specifications;

(c) Bids from Joint Ventures are acceptable.

**18 Period of
Validity of Bids**

18.1 Bids shall remain valid for the period **specified in theBDS** after the bid submission deadline date prescribed by the Purchaser in accordance with ITB 22.1. A bid valid for a shorter period shall

be rejected by the Purchaser as non-responsive.

- 18.2 In exceptional circumstances, prior to the expiration of the bid validity period, the Purchaser may request bidders to extend the period of validity of their bids. The request and the responses shall be made in writing. If a Bid Security is requested in accordance with ITB Clause 19, it shall also be extended for a corresponding period. A Bidder may refuse the request without forfeiting its Bid Security. A Bidder granting the request shall not be required or permitted to modify its bid, except as provided in ITB Sub-Clause 18.3.
- 18.3 If the award is delayed by a period exceeding fifty-six (56) days beyond the expiry of the initial bid validity, the Contract price shall be determined as follows:
- (a) In the case of fixed price Contracts, the Contract price shall be the bid price adjusted by the factor **specified in the BDS** for each week or part of the week that has elapsed from the expiration of the initial bid validity to the date of notification of award to the successful bidder.
 - (b) In the case of adjustable price Contracts, no adjustment shall be made.
 - (c) In any case, bid evaluation shall be based on the bid Price without taking into consideration the applicable correction from those indicated above.

19 Bid Security

- 19.1 The Bidder shall furnish as part of the Technical Part of its bid, a Bid Security, if required, as **specified in the BDS**.
- 19.2 Not used.
- 19.3 The Bid Security shall be in the amount **specified in the BDS** and denominated in Indian Rupees or a freely convertible currency, and shall:
- (a) at the bidder's option, be in the form of either a certified check, demand draft, letter of credit, or a bank guarantee from a Nationalized /Scheduled Bank in India, or another security **specified in the BDS**;
 - (b) be substantially in accordance with one of the forms of Bid Security included in Section IV, Bidding Forms, or other form approved by the Purchaser prior to bid submission;
 - (c) be payable promptly upon written demand by the Purchaser in case the conditions listed in ITB Clause 19.7 are invoked;
 - (d) be submitted in its original form; copies will not be accepted;
 - (e) remain valid for a period of 45 days beyond the original validity period of the bids, or beyond any period of extension of bid validity, if so requested under ITB Clause 18.2.
- 19.4 If a Bid Security is required in accordance with ITB Sub-Clause 19.1, any bid not accompanied by a substantially responsive Bid Security shall be rejected by the Purchaser as non-responsive.
- 19.5 The Bid Security of unsuccessful Bidders shall be returned as promptly as possible upon the successful Bidder's signing the Contract and furnishing the Performance Security pursuant to ITB Clause 44.
- 19.6 The Bid Security of the successful Bidder shall be returned as promptly as possible once the successful Bidder has signed the Contract and furnished the required performance security.
- 19.7 The Bid Security may be forfeited:
- (a) if a Bidder
 - (i) withdraws its bid during the period of bid validity specified by the Bidder in the Letter of Bid (Technical Part and/or Financial Part), except as provided in ITB Sub-Clause 18.2;

or

- (ii) does not accept the correction of errors in pursuant to ITB 35,

or

- (b) if the successful Bidder fails to:

- (i) sign the Contract in accordance with ITB Clause 43; or
- (ii) furnish a Performance Security in accordance with ITB Clause 44.

19.8 Not used.

19.9 If a bid security is **not required in the BDS**, and

- (a) if a Bidder withdraws its bid during the period of bid validity specified by the Bidder on the Letter of Bid Form, except as provided in ITB 18.2, or does not accept the correction of errors pursuant to ITB 35; or
- (b) if the successful Bidder fails to sign the Contract in accordance with ITB 43; or furnish a performance security in accordance with ITB 44;

the Borrower may, **if provided for in the BDS**, declare the Bidder ineligible to be awarded a Contract by the Purchaser for a period of time **as stated in the BDS**.

20 Format and Signing of Bid

- 20.1 The Bidder shall prepare the Bid as per details given in ITB 21.
- 20.2 The bid shall be signed by a person duly authorized to sign on behalf of the Bidder. The authorization shall consist of a written confirmation **as specified in the BDS** and shall be uploaded along with the bid.
- 20.3 Not used.
- 20.4 Corrections if any in the bid can be carried out by editing the information before electronic submission on e-procurement portal.

D. Online Submission of Bids

21 Preparation of Bids

- 21.1 Bids, both Technical and Financial Parts, shall be submitted online on the e-procurement system specified in BDS 7.1. Detailed guidelines for viewing bids and submission of online bids are given on the website. The Invitation for Bids under this Project is published on this website. Any citizen or prospective bidder

can logon to this website and view the Invitation for Bids and can view the details of goods for which bids are invited. A prospective bidder can submit its bid online; however, the bidder is required to have enrolment/registration in the website and should have valid Digital Signature Certificate (DSC) in the form of smart card/e-token obtained from any authorised certifying agency of Government of India (for class of DSC **specified in BDS**). The bidder should register in the website using the relevant option available. Then the Digital Signature registration has to be done with the e-token, after logging into the website. The bidder can then login the website through the secured login by entering the password of the e-token & the user id/ password chosen during registration. After getting the bid schedules, the Bidder should go through them carefully and submit the specified documents, along with the bid, otherwise the bid will be rejected.

21.2 The completed bid comprising of documents indicated in ITB 12, should be uploaded on the e-procurement portal along with scanned copies of requisite certificates as are mentioned in different sections in the bidding document and scanned copy of the bid security.

21.3 All the documents are required to be signed digitally by the bidder. After electronic online bid submission, the system generates a unique bid identification number which is time stamped as per server time. This shall be treated as acknowledgement of bid submission.

21.4 Physical, Email, Telex, Cable or Facsimile bids will be rejected as non-responsive.

22 Deadline for Submission of Bids

22.1 Bids must be uploaded online no later than the date and time **specified in the BDS**.

22.2 The Purchaser may, at its discretion, extend the deadline for the submission of bids by amending the Bidding Documents in accordance with ITB Clause 8, in which case all rights and obligations of the Purchaser and Bidders previously subject to the deadline shall thereafter be subject to the deadline as extended.

23 Late Bids

23.1 The electronic bidding system would not allow any late submission of bids after due date & time as per server time.

24 Withdrawal, Substitution, and Modification of Bids

24.1 Bidders may modify their bids by using appropriate option for bid modification on the e-procurement portal, before the deadline for submission of bids. For this the bidder need not make any additional payment towards the cost of bid document. For bid modification and consequential re-submission, the bidder is not

required to withdraw his bid submitted earlier. The last modified bid submitted by the bidder within the bid submission time shall be considered as the bid. For this purpose, modification/withdrawal by other means will not be accepted. In online system of bid submission, the modification and consequential re-submission of bids is allowed any number of times. A bidder may withdraw his bid by using appropriate option for bid withdrawal, before the deadline for submission of bids, however, if the bid is withdrawn, re-submission of the bid is not allowed (or allowed **if specified in BDS**).

- 24.2 Bids requested to be withdrawn in accordance with ITB Sub-Clause 24.1 shall not be opened.
- 24.3 No bid may be withdrawn, substituted, or modified in the interval between the deadline for submission of bids and the expiration of the period of bid validity specified by the Bidder on the Letter of Bid (Technical Part and/or Financial Part) or any extension thereof.

**25 Public
Opening of
Technical Parts
of Bids**

- 25.1. The Purchaser shall publicly open Technical Parts of all bids received by the deadline, at the date, time and place **specified in the BDS**, in the presence of Bidder's designated representatives and anyone who chooses to attend, and this could also be viewed by the bidders online. The Financial Parts of the bids shall remain unopened in the e-procurement system, until the subsequent public opening, following the evaluation of the Technical Parts of the Bids. In all cases, original documents submitted as specified in ITB 12.3 shall be first scrutinized, and Bids that do not comply with the provisions of ITB 12.3 will be declared non-responsive and will not be opened. Thereafter, bidder's names, and such other details as the Purchaser may consider appropriate will be notified online as Technical Part bid opening summary.

In the event of the specified date of bid opening being declared a holiday for the Purchaser, the bids will be opened at the appointed time and location on the next working day.

- 25.2 The electronic summary of the bid opening will be generated and uploaded online. The Purchaser will also prepare minutes of the Bid opening, including the information disclosed and upload the same for viewing online. Only Technical Parts of Bids, alternative bids - Technical Parts if permitted in ITB 13 that are opened at Bid opening shall be considered further for evaluation.

E. Evaluation of Bids – General Provisions

- 26 Confidentiality** 26.1 Information relating to the examination, evaluation, comparison, and post-qualification of bids, and recommendation of Contract award, shall not be disclosed to bidders or any other persons not officially concerned with such process until information on Contract Award is communicated to all Bidders in accordance with ITB 42.
- 26.2 Any effort by a Bidder to influence the Purchaser in the examination, evaluation, comparison, and post-qualification of the bids or Contract award decisions may result in the rejection of its Bid.
- 26.3 Notwithstanding ITB Sub-Clause 26.2, from the time of bid opening to the time of Contract Award, if any Bidder wishes to contact the Purchaser on any matter related to the bidding process, it should do so in writing.
- 27 Clarification of Bids** 27.1 To assist in the examination, evaluation, comparison of the bids and post-qualification of the Bidders, the Purchaser may, at its discretion, ask any Bidder for a clarification of its Bid. Any clarification submitted by a Bidder in respect to its Bid, that is not in response to a request by the Purchaser shall not be considered. The Purchaser's request for clarification and the response shall be in writing. No change, including any voluntary increase or decrease, in the prices or substance of the Bid shall be sought, offered, or permitted, except to confirm the correction of arithmetic errors discovered by the Purchaser in the Evaluation of the bids, in accordance with ITB Clause 35.
- 27.2 If a Bidder does not provide clarifications of its bid by the date and time set in the Purchaser's request for clarification, its bid may be rejected.
- 28 Deviations, Reservations, Omissions** 28.1 During the evaluation of bids, the following definitions apply:
- (a) "Deviation" is a departure from the requirements specified in the Bidding Documents;
- (b) "Reservation" is the setting of limiting conditions or withholding from complete acceptance of the requirements specified in the Bidding Documents; and
- (c) "Omission" is the failure to submit part or all of the information or documentation required in the Bidding Documents.
- 29 Nonconformities, Errors and Omissions** 29.1 Provided that a Bid is substantially responsive, the Purchaser may waive any nonconformities or omissions in the Bid which do not constitute a material deviation, reservation or omission.

- 29.2 Provided that a Bid is substantially responsive, the Purchaser may request that the Bidder submit the necessary information or documentation, within a reasonable period of time, to rectify nonmaterial nonconformities or omissions in the Bid related to documentation requirements. Such omission shall not be related to any aspect of the price or substance of the Bid. Failure of the Bidder to comply with the request may result in the rejection of its Bid.
- 29.3 Provided that a Bid is substantially responsive, the Purchaser shall rectify quantifiable nonmaterial nonconformities related to the Bid Price. To this effect, the Bid Price shall be adjusted, for comparison purposes only, to reflect the price of a missing or non-conforming item or component in the manner specified **in the BDS.**

Evaluation of Technical Parts of Bids

- 30 Evaluation of Technical Parts** 30.1 In evaluating the Technical Parts of each Bid, the Purchaser shall use the criteria and methodologies listed in ITB 31, ITB 32, and Section III, Evaluation and Qualification Criteria. No other evaluation criteria or methodologies shall be permitted.
- 31 Determination of Responsiveness** 31.1 The Purchaser's determination of a bid's responsiveness is to be based on the contents of the bid itself as defined in ITB 11.
- 31.2 A substantially responsive Bid is one that meets the requirements of the Bidding Documents without material deviation, reservation, or omission. A material deviation, reservation, or omission is one that:
- (a) If accepted, would
 - (i) affect in any substantial way the scope, quality, or performance of the Goods and Related Services specified in the Contract; or
 - (ii) limit in any substantial way, inconsistent with the Bidding Documents, the Purchaser's rights or the Bidder's obligations under the Contract; or
 - (b) if rectified would unfairly affect the competitive position of other bidders presenting substantially responsive bids.
- 31.2.1 Bids from Agents, without proper authorization from the manufacturer as per Section IV, shall be treated as non-responsive.
- 31.3.1 The Purchaser shall examine the bids to confirm that all documents and technical documentation requested in ITB Clause 11 have been provided, and to determine the completeness of

each document submitted.

31.3.2 The Purchaser shall examine the bid to confirm that the Bidder has accepted all terms and conditions specified in GCC and the SCC without material deviations or reservations. Deviations from or objections or reservations to critical provisions such as those concerning Performance Security (GCC Clause 18), Warranty (GCC Clause 28), Force Majeure (Clause 32), Limitation of liability (GCC Clause 30), Governing law (GCC Clause 9) and Taxes & Duties (GCC Clause 17) will be deemed to be a material deviation. The Purchaser's determination of a bid's responsiveness is to be based on the contents of the bid itself without recourse to extrinsic evidence.

31.4 If a bid is not substantially responsive to the Bidding Documents, it shall be rejected by the Purchaser and may not subsequently be made responsive by the Bidder by correction of the material deviation, reservation, or omission.

32 Qualification of the Bidders

32.1 The Purchaser shall determine, to its satisfaction, whether all eligible Bidders, whose Bids have been determined to be substantially responsive to the bidding document, meet the Qualification Criteria specified in Section III, Evaluation and Qualification Criteria.

32.2 The determination shall be based upon an examination of the documentary evidence of the Bidder's qualifications submitted by the Bidder, pursuant to ITB 17. The determination shall not take into consideration the qualifications of other firms such as the Bidder's subsidiaries, parent entities, affiliates, Sub-Contractors (other than specialized Sub-Contractors if permitted in the bidding document), or any other firm(s) different from the Bidder.

32.3 If a Bidder does not meet the qualifying criteria specified in Section III, Evaluation and Qualification Criteria, its Bid shall be rejected by the Purchaser and may not subsequently be made responsive by correction of the material deviation, reservation, or omission.

32.4 Only Bids that are both substantially responsive to the bidding document, and meet all Qualification Criteria shall have the Financial Parts of their Bids opened at the second public opening

Public Opening of Financial Parts of Bids

33 Public Opening of Financial Parts

33.1 Following the completion of the evaluation of the Technical Parts of the Bids, and the Bank has issued its no objection (if applicable), the Purchaser shall notify in writing those Bidders who have failed to meet the Qualification Criteria and/or whose

Bids were considered non-responsive to the requirements in the bidding document, advising them of the following information:

- (a) their Technical Part of Bid failed to meet the requirements of the bidding document;
- (b) their Financial Part of the Bid shall not be opened; and
- (c) notify them of the date and time for public opening of the Financial Parts of the Bids. Financial Parts of the bids shall not be opened earlier than seven (7) days from the communication of technical evaluation results to the bidders.

33.2 The Purchaser shall, simultaneously, notify in writing those Bidders whose Technical Parts have been evaluated as substantially responsive to the bidding document and met the Qualification Criteria, advising them of the following information:

- (a) their Bid has been evaluated as substantially responsive to the bidding document and met the Qualification Criteria;
- (b) their Financial Part of Bid will be opened at the public opening of Financial Parts;
- (c) notify them of the date and time of the second public opening of the Financial Parts of the Bids, as **specified in the BDS**.

33.3 The opening date should allow Bidders sufficient time to make arrangements for attending the opening. The Financial Part of the Bid shall be opened publicly in the presence of Bidders' designated representatives and anyone who chooses to attend, and this could also be viewed by the bidders online. The bidder's names, the Bid prices, the total amount of each bid, including any discounts and Alternative Bid – Financial Part, and such other details as the Purchaser may consider appropriate will be notified online by the Purchaser at the time of bid opening.

In the event of the specified date of bid opening being declared a holiday for the Purchaser, the bids will be opened at the appointed time and location on the next working day.

33.4 The electronic summary of the bid opening will be generated and uploaded online. The Purchaser will also prepare minutes of the Bid opening, including the information disclosed and upload the same for viewing online. Only Financial Part of Bids, Financial Parts of Alternative Bids and discounts that are opened and read out at Bid opening shall be considered further for evaluation.

Evaluation of Financial Parts of Bids

- 34 Evaluation of Financial Parts**
- 34.1 To evaluate the Financial Part of each Bid, the Purchaser shall consider the following:
- (a) evaluation will be done for Items or Lots (Contracts), as specified **in the BDS**; and the Bid Price as quoted in accordance with ITB 14;
 - (b) Not used;
 - (c) price adjustment due to discounts offered in accordance with ITB 14.4;
 - (d) Not used;
 - (e) price adjustment due to quantifiable nonmaterial nonconformities in accordance with ITB 29.3; and
 - (f) the additional evaluation factors specified in Section III, Evaluation and Qualification Criteria.
- 34.2 The estimated effect of the price adjustment provisions of the Conditions of Contract, applied over the period of execution of the Contract, shall not be taken into account in Bid evaluation.
- 34.3 If this bidding document allows Bidders to quote separate prices for different lots (Contracts), the methodology to determine the lowest evaluated cost of the lot (Contract) combinations, including any discounts offered in the Letter of Bid - Financial Part, is specified in Section III, Evaluation and Qualification Criteria.
- 34.4 The Purchaser's evaluation of a Bid shall include (i) price quoted EXW including GST as applicable on the finished goods; (ii) other taxes, if any, payable on finished goods; (iii) price for inland transportation, insurance, and other local services required to convey the Goods to their Final Destination; and (iv) price for Related Services, if any.
- 34.5 The Purchaser's evaluation of a Bid may require the consideration of other factors, in addition to the Bid price quoted in accordance with ITB 14. These factors may be related to the characteristics, performance, and terms and conditions of purchase of the Goods and Related Services. The effect of the factors selected, if any, shall be expressed in monetary terms to facilitate comparison of Bids, unless otherwise specified **in the BDS** from amongst those set out in Section III, Evaluation and Qualification Criteria. The criteria and methodologies to be used shall be as specified in ITB 34.1 (f).
- 35 Correction of**
- 35.1 The e-procurement system automatically calculates the total amount

Arithmetical Errors		from unit rates and quantities and the system also automatically populates the amount in words from the amount in figures and therefore there is no scope of discrepancy and need for arithmetic correction.
36 Conversion to Single Currency	36.1	Not applicable.
37 Margin of Domestic Preference	37.1	Not applicable.
38 Comparison of Financial Parts		The Purchaser shall compare the evaluated prices of all substantially responsive bids to determine the lowest-evaluated bid, in accordance with ITB Clause 34
39 Purchaser's Right to Accept Any Bid, and to Reject Any or All Bids	39.1	The Purchaser reserves the right to accept or reject any bid, and to annul the bidding process and reject all bids at any time prior to Contract award, without thereby incurring any liability to Bidders. In case of annulment, all documents submitted and specifically, bid securities, shall be promptly returned to the Bidders.

F. Award of Contract

40 Award Criteria	40.1	Subject to ITB 39.1 the Purchaser shall award the Contract to the Bidder whose bid has been determined to be the lowest evaluated bid and is substantially responsive to the Bidding Documents, provided further that the Bidder is determined to be qualified to perform the Contract satisfactorily.
41 Purchaser's Right to Vary Quantities at Time of Award	41.1	At the time the Contract is awarded, the Purchaser reserves the right to increase or decrease the quantity of Goods and Related Services originally specified in Section VII, Schedule of Requirements, provided this does not exceed the percentages specified in the BDS , and without any change in the unit prices or other terms and conditions of the bid and the Bidding Documents.
42 Notification of Award	42.1	Prior to the expiration of the period of bid validity, the Purchaser shall notify the successful Bidder, in writing, that its Bid has been accepted. The notification letter (hereinafter called "Letter of Acceptance") shall specify the sum that the purchaser will pay in consideration of the supply of Goods (hereinafter called "the Contract Price").
Publication of Award	42.2	At the same time the Purchaser shall publish in a National website (GOI web site - http://tenders.gov.in or GoI Central Public Procurement Portal https://eprocure.gov.in/cppp/) or on the Purchaser's website with free access if available, or in the official

gazette, the results identifying the bid and lot numbers and the following information: (i) name of each Bidder who submitted a Bid; (ii) bid prices as read out at bid opening; (iii) name and evaluated prices of each Bid that was evaluated; (iv) name of bidders whose bids were rejected and the reasons for their rejection; and (v) name of the successful Bidder, and the price it offered, as well as the duration and summary scope of the Contract awarded.

Recourse to Unsuccessful Bidders

42.3 The Purchaser shall promptly respond in writing to any unsuccessful Bidder who, after Publication of Contract award, requests in writing the grounds on which its bid was not selected.

42.4 Until a formal Contract is prepared and executed, the notification of award shall constitute a binding Contract.

42.5 Upon the successful Bidder's furnishing of the performance security and signing the Contract Form pursuant to ITB Clause 43, the Purchaser will promptly notify each unsuccessful Bidder and will discharge its bid security, pursuant to ITB Clause 19.5

43 Signing of Contract

43.1 Promptly after notification, the Purchaser shall send the successful Bidder the Contract Agreement.

43.2 Within twenty-one (21) days of receipt of the Contract Agreement, the successful Bidder shall sign, date, and return it to the Purchaser.

44 Performance Security

44.1 Within twenty-one (21) days of the receipt of notification of award from the Purchaser, the successful Bidder, if required, shall furnish the Performance Security in accordance with the GCC, using for that purpose the Performance Security Form included in Section X Contract forms, or another Form acceptable to the Purchaser. Failure of the successful Bidder to submit the above-mentioned Performance Security or sign the Contract shall constitute sufficient grounds for the annulment of the award and forfeiture of the Bid Security. In that event the Purchaser may award the Contract to the next lowest evaluated Bidder, whose bid is substantially responsive and is determined by the Purchaser to be qualified to perform the Contract satisfactorily.

SECTION II - BIDDING DATA SHEET

The following specific data for the goods to be procured shall complement, supplement, or amend the provisions in the Instructions to Bidders (ITB). Whenever there is a conflict, the provisions herein shall prevail over those in ITB.

ITB Clause Reference	A. General	
ITB 1.1	<p>The Purchaser is: The Executive Engineer Burdwan Investigation & Planning Division Irrigation & Waterways Directorate Govt. of West Bengal PurtaBhawan, 3rd Floor Purba Burdwan-713103, West Bengal e-mail: eebipd2012@gmail.com</p> <p>The following Executive Engineers will implement the establishment of RTDAS in different districts of West Bengal as per Memo No. 169-IFC /IW/0/IFC-4M-52/2014(Pt-I), Dated 08.05.2017 of the Secretary to the Govt. of west Bengal, I&W Department as mentioned below:-</p>	
	Sl no.	Name of Executive Engineers & Divisions
	Name of districts	
	1	Executive Engineer, Burdwan Investigation & Planning Division, Burdwan
	2	Executive Engineer-I, Investigation & Planning Division (South), Jalsampad Bhavan, Bidhannagar, Kolkata-91
	3	Executive Engineer, Mayurakshi Head Quarter Division, Birbhum
	4	Executive Engineer, Purulia Investigation and Planning Division, Purulia
	5	Executive Engineer, KKB Division, Purba Medinipore
	6	Executive Engineer, Investigation and Planning Division (Central), Berhampore, Murshidabad
	7	Executive Engineer, Jalpaiguri Irrigation Division, Jalpaiguri
	7a	Shri Subhodip Sarkar, Research Officer, River Research Institute, Coochbehar, (Assisting EE, Jalpaiguri Irrigation Division in execution relating to establishment of RTDAS)
		Darjeeling, Jalpaiguri, Alipurduar and Coochbehar

<p>ITB 1.1</p>	<p>The name and identification number of the NCB is: Supply Installation Testing Commissioning and Maintenance of Real Time Data Acquisition System (RTDAS) with telemetry of Irrigation and Waterways Department West Bengal Under National Hydrology Project (NHP) And Integrate with Data Center located at Kolkata IFB No. WBIW/NHP/RTDAS/IFB-01/19-20</p> <p>Procurement Plan Ref. No. NHP-2018-19-WBSW-995987-GO-NCB-DE The number, identification and names of the lots (Contracts): One</p>
<p>ITB 1.2(a)</p>	<p>The Purchaser shall use the electronic-procurement system specified in BDS 7.1 to manage this Bidding process.</p>
<p>ITB 2.1</p>	<p>The Borrower is: Government of India</p> <p>Loan Agreement Amount: US\$ 175 million</p>
<p>ITB 2.1</p>	<p>The name of the Project is: <i>National Hydrology Project.</i></p>
<p>ITB 4.1</p>	<p>A Bidder may be a firm that is a private entity, a government-owned entity—subject to ITB 4.5—or any combination of such entities in the form of a joint venture (JV) under an existing agreement or with the intent to enter into such an agreement supported by a letter of intent. In the case of a joint venture, all members shall be jointly and severally liable for the execution of the Contract in accordance with the Contract terms. The JV shall nominate a Representative who shall have the authority to conduct all business for and on behalf of any and all the members of the JV during the bidding process and, in the event the JV is awarded the Contract, during Contract execution.</p> <p>Numbers of members/firms in a joint venture shall not be more than two including the lead partner.</p>
<p>ITB 4.4</p>	<p>A list of firms debarred from participating in World Bank projects is available at http://www.worldbank.org/debarr</p>
<p>B. Contents of Bidding Documents</p>	
<p>ITB 7.1</p>	<p>Electronic –Procurement System</p> <p>The Purchaser shall use the following electronic-procurement system to manage this Bidding process:</p> <p>https://wbtenders.gov.in</p>
<p>ITB 7.1a</p>	<p>A pre-bid meeting will be held: Yes</p> <p style="text-align: center;">Date of pre-bid meeting: 20/06/2019;</p> <p>Time: 11:30 HRS</p>

	<p>Address: Office of the Superintending Engineer, Investigation & Planning Circle-II, Jalasampad Bhawan, 5th Floor, Block-DF, Sector - I, Salt Lake City, Kolkata-700 091 Telephone: +91332358716 Facsimile number: +91332358716 Electronic mail address: seip2iwd@gmail.com</p> <p>Contact Persons: Sri ,Tapan Biswas Superintending Engineer Sri Manas Khan, Executive Engineer</p>																												
ITB 8.1	<p>The addendum will appear on the e-procurement system under https://wbenders.gov.in under “<i>Latest Corrigendum</i>” and email notification will be automatically sent to those Bidders who started working on this tender to their ‘<i>My Tenders</i>’ area.</p>																												
<p>C. Preparation of Bids</p>																													
ITB 11.2(j)	<p>The Bidder shall submit the following additional documents in its bid:</p> <ol style="list-style-type: none"> The following details shall also be provided by Bidders [to be submitted under ‘My Documents (OID)’ Folder] <table border="1" data-bbox="376 882 1501 1503"> <thead> <tr> <th data-bbox="376 882 469 943">Sl. No.</th> <th data-bbox="469 882 683 943">Folder Name</th> <th data-bbox="683 882 970 943">File Description</th> <th colspan="2" data-bbox="970 882 1501 943">Details</th> </tr> </thead> <tbody> <tr> <td data-bbox="376 943 469 1093" rowspan="3" style="text-align: center;">I</td> <td data-bbox="469 943 683 1093" rowspan="3" style="text-align: center;">Certificates</td> <td data-bbox="683 943 970 1093" rowspan="3" style="text-align: center;">Certificates.pdf</td> <td data-bbox="970 943 1018 981" style="text-align: center;">1</td> <td data-bbox="1018 943 1501 981">PAN Card</td> </tr> <tr> <td data-bbox="970 981 1018 1019" style="text-align: center;">2</td> <td data-bbox="1018 981 1501 1019">GST Registration Certificate</td> </tr> <tr> <td data-bbox="970 1019 1018 1093" style="text-align: center;">3</td> <td data-bbox="1018 1019 1501 1093">Latest Income Tax Return and I.T Dept. Return Acknowledgement /Receipt.</td> </tr> <tr> <td data-bbox="376 1093 469 1429" rowspan="3" style="text-align: center;">II</td> <td data-bbox="469 1093 683 1429" rowspan="3" style="text-align: center;">Company Details</td> <td data-bbox="683 1093 970 1429" rowspan="3" style="text-align: center;">Companydetails.pdf 1 Companydetails.pdf 2</td> <td data-bbox="970 1093 1018 1173" style="text-align: center;">1</td> <td data-bbox="1018 1093 1501 1173">For Proprietorship Firms (Trade Licence)</td> </tr> <tr> <td data-bbox="970 1173 1018 1285" style="text-align: center;">2</td> <td data-bbox="1018 1173 1501 1285">For Partnership Firms (Partnership Deed, Trade License, Form-VIII/ Memorandum of Registration)</td> </tr> <tr> <td data-bbox="970 1285 1018 1429" style="text-align: center;">3</td> <td data-bbox="1018 1285 1501 1429">For all Companies (Incorporation Certificate, Trade License, Memorandum of Articles of ROC, List of owners/ Directors/Board Members)</td> </tr> <tr> <td data-bbox="376 1429 469 1503" style="text-align: center;">III</td> <td data-bbox="469 1429 683 1503" style="text-align: center;">Credential of Work</td> <td data-bbox="683 1429 970 1503" style="text-align: center;">Credential.pdf 1 Credential.pdf 2</td> <td data-bbox="970 1429 1018 1503" style="text-align: center;">1</td> <td data-bbox="1018 1429 1501 1503">Work completion Certificates.</td> </tr> </tbody> </table> <ol style="list-style-type: none"> Certification of incorporation of the bidder and manufacturer The bidder shall clearly confirm that all facilities exist with him (or manufacturer, as applicable) in his factory for inspection and testing and these can be accessed by the Purchaser or his representative for inspection. Technical schedules of goods as required by technical specifications. Descriptive Documents, drawings, notes and references of operating and assembly of mechanical parts a detailed description of the Goods essential technical and performance characteristics. 	Sl. No.	Folder Name	File Description	Details		I	Certificates	Certificates.pdf	1	PAN Card	2	GST Registration Certificate	3	Latest Income Tax Return and I.T Dept. Return Acknowledgement /Receipt.	II	Company Details	Companydetails.pdf 1 Companydetails.pdf 2	1	For Proprietorship Firms (Trade Licence)	2	For Partnership Firms (Partnership Deed, Trade License, Form-VIII/ Memorandum of Registration)	3	For all Companies (Incorporation Certificate, Trade License, Memorandum of Articles of ROC, List of owners/ Directors/Board Members)	III	Credential of Work	Credential.pdf 1 Credential.pdf 2	1	Work completion Certificates.
Sl. No.	Folder Name	File Description	Details																										
I	Certificates	Certificates.pdf	1	PAN Card																									
			2	GST Registration Certificate																									
			3	Latest Income Tax Return and I.T Dept. Return Acknowledgement /Receipt.																									
II	Company Details	Companydetails.pdf 1 Companydetails.pdf 2	1	For Proprietorship Firms (Trade Licence)																									
			2	For Partnership Firms (Partnership Deed, Trade License, Form-VIII/ Memorandum of Registration)																									
			3	For all Companies (Incorporation Certificate, Trade License, Memorandum of Articles of ROC, List of owners/ Directors/Board Members)																									
III	Credential of Work	Credential.pdf 1 Credential.pdf 2	1	Work completion Certificates.																									

	<p>7. A clause-by-clause commentary on the Purchaser's technical specifications demonstrating substantial responsiveness of the Goods and Services to those specifications or a statement of deviations and exceptions to the provisions of the Technical Specifications.</p> <p>8. For purposes of the commentary to be furnished pursuant to Paragraph 6 above, the Bidder shall note that standards for workmanship, material and goods, and references to brand names or catalogue numbers designated by the Purchaser in its Technical Specifications are intended to be descriptive only and not restrictive. The Bidder may substitute alternative standards, brand names and/or catalogue numbers in its bid, provided that it demonstrates to the Purchaser's satisfaction that the substitutions ensure substantial equivalence to those designated in the Technical Specifications</p> <p>9. The documentary evidence of the goods and services eligibility shall consist of a statement in the Price Schedule on the country of origin of the goods and services offered which shall be confirmed by a certificate of origin at the time of shipment</p> <p>10. Non-manufacturer bidders will submit the manufacturer's authorization Form as per Proforma in Section IV.</p> <p>11. The following details shall also be provided by Indian Bidders:</p> <p style="margin-left: 20px;">a. Registration details of the company under GST and other laws as may be applicable.</p> <p style="margin-left: 40px;">- The bidders from outside India shall provide the corresponding details of Income Tax registration, Social Security Number, details regarding Registration under goods & services tax (as may be applicable) etc.</p> <p>12. The bidder shall disclose instance of previous past performance that may have resulted into adverse actions taken against the bidder during the last five years.</p> <p>13. All document required in Section 3: Evaluation & Qualification Criteria.</p>
--	---

ITB 11.2(k) In addition to the requirements under ITB 11.1, bids submitted by a JV shall include a copy of the Joint Venture Agreement entered into by all members. Alternatively, a letter of intent to execute a Joint Venture Agreement in the event of a successful bid shall be signed by all members and submitted with the bid, together with a copy of the proposed Agreement.

ITB 11.3(a) **Note for Bidders: Bidders have to submit filled up format of ' Letter of Bid – Financial Part' in 'Financial Folder' only.**

ITB 11.3(d)	No additional documents other than those required in ITB 11.1, ITB 11.2 and 11.3 are required to be submitted along with Financial Bid.
ITB 12	Note for Bidders: Bidders have to submit the bids on the e-procurement portal along with the relevant required documents. The rest of the forms shall be downloaded by the bidders and filled up. The filled up pages shall then be scanned and uploaded on the e-procurement portal along with the scanned copies of the supporting documents.

ITB 12.3	For submission of original documents, the Purchaser's address is: The Executive Engineer Burdwan Investigation & Planning Division Irrigation & Waterways Directorate Govt. of West Bengal PurtaBhawan, 3 rd Floor Purba Burdwan-713103, West Bengal Tel: +91342-2646799 Fax: +91342-2646799 e-mail: eebipd2012@gmail.com Country: INDIA
ITB 13.1	Alternative Bid shall not be considered.
ITB 14.5	The prices quoted by the Bidder " <i>shall not</i> " be subject to adjustment during the performance of the Contract
ITB 14.7	The Incoterms edition is Incoterms 2010.
ITB 14.8 (a) (iii)	"Final destination (Project Site)": <i>as mentioned in Schedule of Requirements.</i>
ITB 14.9	<i>As per latest instructions from Government of India.</i>
ITB 16.2	<i>Omitted.</i>
ITB 16.4	Manufacturer has to ensure that all equipment would be supported for a minimum period of 10 years after commissioning.
ITB 17.2 (b) (i)	Manufacturer's authorization is: <i>required as per proforma in Section IV.</i>
ITB 17.2 (b)iii	After Sales service is required which shall be provided by the Supplier or alternatively by its Agent in case of a foreign bidder.
ITB 18.1	The bid validity period shall be 90 days.
ITB 18.3(A)	<i>The factor shall be 1.0007692 (multiplicative) per week</i>
ITB 19.1	Bids shall include a Bid Security (issued by bank) included in Section IV Bidding Forms.
ITB 19.3	The amount of the Bid Security shall be: Rs 20,00,000/- (Rs. Twenty Lakh only)
ITB 19.3 (a)	Other types of acceptable securities are: Fixed Deposit/Time Deposit Certificate issued by a Nationalized or Scheduled Bank located in India for equivalent or higher values are acceptable provided it is pledged in favour of <i>The Executive Engineer, Burdwan I&P Division</i> and such pledging has been noted and suitably endorsed by the bank issuing the certificate
ITB 19.8	The bid security of a JV must be in the name of the legally enforceable JV that submits the bid. If the JV has not been legally constituted into a legally

	enforceable JV at the time of bidding, The bid security shall be in the names of all future members. as named in the letter of intent referred to in ITB 4.1 and ITB 11.2. The bid security of a JV must be in the name of the JV or in name of lead partner or as per JV condition
ITB 19.9	<i>Omitted</i>
ITB 20.2	The written confirmation of authorization to sign on behalf of the Bidder shall consist of: <ol style="list-style-type: none"> 1. <i>Original Power of Attorney;</i> 2. <i>Original affidavit vouching for the correctness of the information furnished and documents uploaded;</i>
ITB 20.3	In case the Bidder is a JV, the Bid shall be signed by an authorized representative of the JV on behalf of the JV, and so as to be legally binding on all the members as evidenced by a power of attorney signed by their legally authorized representatives.
	D. Online Submission and Opening of Bids
ITB 21.1	<p>Class of DSC required is: <i>Class II or III</i></p> <p>The Bid will be published online for the work specified in Invitation for Bid (IFB). The Bid is invited in Double Covers system from the registered and eligible firms through e-procurement portal of Government of West Bengal https://wbtenders.gov.in. Detailed guidelines for viewing Bids and submission of online Bids are given on the website. Any citizen or prospective Bidder can logon to this website and view the Invitation for Bids and can view the details of works for which Bids are invited. The prospective Bidder can submit Bids on line; however, the Bidder is required to have enrolment/registration in the website and should have valid Digital Signature Certificate (DSC), for signing and encryption issued by the same Certifying Authority, in the form of smart card/e-token. Prospective Bidders shall locate the Bid by typing WBIW/NHP in the search engine provided, or by logging-in using their passwords. They may also visit the official website of Irrigation & Waterways Department, Government of West Bengal website www.wbiwd.gov.in and locate the same there by clicking the “e-Procurement” link. The tender timeline is available in the critical date section of this tender published in https://wbtenders.gov.in.</p> <p><i>Online Bidder registration process:</i></p> <p>Bidders willing to take part in the process of e-procurement are required to obtain Digital Signature Certificate (DSC) at their own cost from any of the authorized ‘Certifying Authorities’ (CA) under Controller of Certifying Authorities (CCA), Department of Electronics & Information Technology (DEIT), Govt. of India (viz. NIC, n-Code Solution, Safescrypt, e-Mudhra Consumer Services Ltd, TCS, MTNL, IDRBT) or as notified by the CA /Finance Department from time to time. DSC is given as a USB e-Token. After obtaining the Class II or Class III Digital Signature Certificate (DSC) from any of the above CA, they are required to register the fact of possessing the DSC through the registration system available in the above mentioned website/s. A list of such licensed CAs’ is also available in the CCA website cca.gov.in. The prospective Contractors / Bidders may contact the e-procurement State Level Help desk located at 7th Floor, Jalasampad Bhavan, Sector-I, Bidhannagar, Kolkata-700091 through e-mail ID: irrigationhelpdesk@gmail.com or dvcsc6816@gmail.com and Telephone No. 033-23346098 on any working day, between 10.00 AM to 5.00 PM for any query on e-procurement, obtaining DSC, training on e-procurement usage, all free of cost.</p> <p><i>Electronics Bidding Process:</i></p>

	<p>The Bidding process shall consist of the following stages:</p> <ul style="list-style-type: none"> i. Downloading of Bid document: Bid document will be available for free download on https://wbtenders.gov.in. However, Bid document fees shall be payable at the time of Bid submission as stipulated in this Bid document. i. Pre-Bid meeting: <i>As specified in IFB.</i> i. Publishing of Corrigendum/Addendum: All Corrigenda/Addenda shall be published on https://wbtenders.gov.in and shall not be available elsewhere. <p>Submission of online Bids:</p> <p>Bidders have to submit their Bids along with supporting documents to support their eligibility, as required in this Bid document on https://wbtenders.gov.in by using their valid DSC e-Token with assigned PIN along with login ID and password. Details of submission procedure have been explained in the 'Bidders Manual' for participating in e-Procurements of the State Government, which is available in the Departmental website www.wbiwd.gov.in. Minimum period of time to be given to the Bidders for submission of Bid is counted from the date on which the notice inviting Bid including e-Bid is actually published in the newspaper(s). In case of publication of the Bid in more than one newspaper, all the advertisements should appear simultaneously on the same day in all newspapers. Also, uploading of the notice including Bid documents in the State Government e-Procurement portal shall be such the Bid documents are to be visible in the website https://wbtenders.gov.in as soon as the brief referral advertisement appears in the newspaper(s).</p> <p>After registration, Bidders shall submit their Technical Bid and Financial Bid online on https://wbtenders.gov.in along with online payment of Bid document fees and Bid Security. All the documents are required to be signed digitally by the bidder. After electronic on line Bid submission, the system generates a unique Bid identification number which is time stamped. This shall be treated as acknowledgement of Bid submission. It is necessary to click on "Freeze Bid" link/ icon to complete the process of Bid submission otherwise the Bid will not get submitted online and the same shall not be available for viewing/ opening during Bid opening process.</p>
<p>ITB 21.2</p>	<p>The Envelope for submitting Document as per ITB 12.3 shall bear the following: ORIGINAL DOCUMENTS AS PER CLAUSE 12.3 for IFB No. WBIW/NHP/RTDAS/IFB-01/19-20 Procurement Plan Ref. No. NHP-2018-19-WBSW-995987-GO-NCB For Supply Installation Testing Commissioning and Maintenance of Real Time Data Acquisition System (RTDAS) with telemetry of Irrigation and Waterways Department West Bengal Under National Hydrology Project (NHP) And Integrate with Data Center located at (Kolkata)West Bengal</p> <p>The Executive Engineer Burdwan Investigation & Planning Division Irrigation & Waterways Directorate Govt. of West Bengal PurtaBhawan, 3rd Floor Purba Burdwan-713103, West Bengal</p>
<p>ITB 22.1</p>	<p>The deadline for uploading of bids is: Date: 09/07/2019 Time:15:00 HRS</p> <p>Only the i) originals of Power of Attorney, ii) the bid security and iii) the Original affidavit vouching for the correctness of the information furnished shall be delivered by post/courier to the address of purchaser, by 15:00 HRS of 09/07/2019.</p>
<p>ITB 24.1</p>	<p>Re-submission of the bid is not allowed if withdrawn.</p>

	Public Opening of Technical Parts of Bids
ITB 25.1	<p>The online bid opening shall take place at:</p> <p>Address: Office of the Superintending Engineer, Investigation & Planning Circle-II, I&WD, Street Address: <i>JalasampadBhawan</i> Floor/ Room number: <i>5thFloor,Block-DF</i> City: <i>Sector-I, Bidhannagar, Kolkata</i> Country: INDIA Date:09/07/2019Time: 15:30 HRS</p>
	E. Evaluation of Bids – General Provisions
ITB 29.3	<p>The adjustment shall be based on the highest price of the item or component as quoted in other substantially responsive Bids, subject to a maximum of the estimated price of the item. If the price of the item or component cannot be derived from the price of other substantially responsive Bids, the Purchaser shall use its best estimate.</p>
	Public Opening of Financial Parts of Bids
ITB 33.2 (c)	<p>Following the completion of the evaluation of the Technical Parts of the Bids, the Purchaser will notify all Bidders of the date and time of the public opening of Financial Parts.</p> <p>The online opening of the Financial Parts of bids (for technically qualified bidders) shall take place at:</p> <p>Address: Office of the Superintending Engineer, Investigation & Planning Circle-II, I&WD, Street Address: <i>JalasampadBhawan</i> Floor/ Room number: <i>5th Floor, Block-DF</i> City: <i>Sector-I, Bidhannagar, Kolkata</i> Country: INDIA Date:<i>[to be notified later]</i> Time: <i>[to be notified later]</i></p>
	Evaluation and Comparison of Bids
ITB 34.1 a	<p><i>Evaluation will be done for all items together.</i></p> <p><i>Bids will not be evaluated for each item separately and single Contract will be concluded with the successful bidder.</i></p>
ITB 34.3	Not applicable.
ITB 34.4	Replace with following:

	<p>The Purchaser's evaluation of a bid will exclude and not take into account:</p> <p>(a) In the case of Goods manufactured in India or goods of foreign origin already located in India, GST and other similar taxes, which will be payable on the goods if a contract is awarded to the Bidder;</p> <p>(b) Not Used.</p> <p>(c) any allowance for price adjustment during the period of execution of the contract, if provided in the bid.</p> <p>But, the purchaser's evaluation of a bid will include i) price for inland transportation, insurance, and other local services required to convey the Goods to their Final Destination; and (ii) price for Related Services, if any.</p>
ITB 34.5	The adjustments are not applicable
ITB 38 & 39	
ITB 41.1	<p style="text-align: center;">F. Award of Contract</p> <p>The maximum percentage by which quantities may be increased is: 15% The maximum percentage by which quantities may be decreased is: 15%</p>

Section III. Evaluation and Qualification Criteria

This Section complements the Instructions to Bidders. It contains the criteria that the Purchaser shall use to evaluate a bid and determine whether a Bidder qualifies in accordance with ITB 32&34. No other criteria shall be used.

TECHNICAL PART

1 Qualification (ITB 32)

1.1 Qualification Criteria (ITB 32.1)

The Purchaser shall assess each Bid against the following Qualification Criteria. Requirements not included in the text below shall not be used in the evaluation of the Bidder's qualifications.

I- Financial Capability

The Bidder shall furnish documentary evidence that it meets the following financial requirement(s):

A) In case of individual Bidder

- i) Capacity to have a cash flow - The Bidder must provide a letter from a reputed bank stating the availability of liquid assets and/or credit facilities exclusively for this Contract only, of no less than **INR 200Lakhs** or its equivalent **amount in a freely convertible currency**.
- ii) The Minimum required annual turnover in respect of supply, installation and commissioning of goods for the successful Bidder in any two of the last five (5) years shall be of **INR 1000Lakhs** or its equivalent amount in a freely convertible currency . Period of 5 years shall be reckoned from 31st march of financial year preceding the year in which bid is published.
- iii) Further, bidder should be in continuous business of supplying and/ or after sale services of products similar to that specified in the 'Schedule of requirement' during the last 5 years prior to date of bid submission.
- iv) Bidder shall furnish the legal status, place of registration and principal place of business of the company or firm or partnership, etc.;
- v) Details of experience and past performance on equipment offered and on those of similar nature within the past seven years (Prior to the date of bid submission) and details of current contracts in hand and other commitments (suggested Proforma given in Section IV) to be submitted by the bidder
- vi) The bidder should furnish a brief write-up, backed with adequate data, explaining his available capacity and experience (both technical and commercial) for the supply of the required equipment within the specified time of completion after the meeting all their current commitments.
- vii) Reports on financial standing of the bidder such as profit and loss statements, balance sheets and auditor's report for the past three years, bankers certificate, etc.
- viii) A firm can submit only one bid in the same bidding process, A bidder who submits or participates in more than one bid will cause all the bids in which the bidder has participated to be disqualified.
- ix) Should possess GST Registration.

B) In case of Joint Venture (JV)

- i) Capacity to have a cash flow: The Bidders must provide a letter from a reputed bank stating the availability of liquid assets and/or credit facilities exclusively for this Contract only, of no less than **INR 200Lakhs** or equivalent **amount in a freely convertible currency** collectively.
- ii) In case of JV, the Minimum required annual turnover in respect of supply, installation and commissioning of goods for the successful Bidder in any two of the last five (5) years shall be of **INR 1000Lakhs** or its equivalent **amount in a freely convertible currency** collectively. Period of 5 years shall be reckoned from 31st march of financial year preceding the year in which bid is published. The lead partner must have minimum annual turnover of **INR 700Lakhs** or its equivalent **amount in a freely convertible currency** in any two of the last five (5) years while other partner must have minimum annual turnover of **INR 300Lakhs** or its equivalent in any two of the last five (5) years
- iii) Further, one member of Joint Venture should be in continuous business of supplying and after sale services of products similar to that specified in the 'Schedule of requirement' during the last 5 years prior to date of bid submission while other member should be in continuous business of supplying and after sale services of products similar to that specified in the 'Schedule of requirement' at least 1 year prior to date of bid submission.
- iv) All members of Joint Venture shall furnish the legal status, place of registration and principal place of business of the company or firm or partnership, etc.;
- v) Details of experience and past performance of all members of Joint Venture on equipment offered and on those of similar nature within the past seven years (Prior to the date of bid submission) and details of current contracts in hand and other commitments (suggested Proforma given in Section IV).
- vi) The lead member of Joint Venture should furnish a brief write-up, backed with adequate data, explaining their available capacity and experience (both technical and commercial) for the supply of the required equipment within the specified time of completion after the meeting all their current commitments.
- vii) Responsibilities in respect of lead firm as well as each of the Joint Venture members shall be clearly indicated in the JV agreement;
- viii) The Joint Venture agreement shall not be cancelled or amended unilaterally without consent of the Purchaser and a statement to this effect should appear in the JV agreement;
- ix) Reports on financial standing of the each JV members such as profit and loss statements, balance sheets and auditor's report for the past three years, banker's certificate, etc.
- x) Atleast one member of Joint Venture should possess GST Registration.

II- Experience and Technical Capacity of Bidder

The Bidder shall furnish documentary evidence to demonstrate that it meets the following experience requirement(s):

- i) **Hydrological, Meteorological (ARS /AWLR /AWS) stations experience**

A) In case of individual Bidder

The bidder must have supplied, tested and commissioned Hydro-Met stations with Satellite /GSM /GPRS based telemetry using equipment /sensors similar to the type specified in the “Section – VII Schedule of Requirements” and provided after sales service to the extent of at least 32 stations (comprising of minimum 1 data logger and sensor at each station) in any two of the year during a period of last 7 years from the last date of submission of bid document and should be in use satisfactorily with no adverse report for at least one year preceding the date of bid opening.

B) In case of Joint Venture (JV)

The JV partners must have supplied, tested and commissioned the Hydro-Met stations with Satellite /GSM /GPRS based telemetry using equipment /sensors similar to the type specified in the “Section – VII Schedule of Requirements” to the extent of at least 32 stations (comprising of minimum 1 data logger and sensor at each station) collectively in any two of the year during a period of last 7 years from the last date of submission of bid document. Out of which the one partner should have supplied, installed, commissioned and provided after sales service satisfactorily to the extent of at least minimum 22 stations (comprising of minimum 1 data logger and sensor at each station) in any two year during a period of last 7 years from the last date of submission of bid document and other partner should have operated and maintained satisfactorily to the extent of at least minimum 10 stations (comprising of minimum 1 data logger and sensor at each station) in any two year during a period of last 7 years from the last date of submission of bid document .

ii) Manufacturer Authorization for Hydro-Met equipment

If the bidder /JV partners is/are not the manufacturer of the hydro-met equipment (i.e. listed in table-1), the bidder/JV shall furnish a legally enforceable authorization from manufacturer in the prescribed Form [Section-IV] assuring full guarantee and warranty obligations as per GCC and SCC for the goods offered;

If the bidder or JV partner, himself is a manufacturer of the hydro-meteorological equipment (listed in Table-1), then a self-authorization suffices.

Further, bidder or JV partners should furnish the documentary evidence from the manufacturer of the hydro-meteorological equipment to establish that the manufacturer has manufactured and supplied the quantity of the hydro-meteorological equipment as per Table-1 below in any two year during a period of last 7 years from the last date of submission of bid document.

Table-1 Compliance for equipment manufacturer

S No	Item	Total quantity to be supplied as per schedule of requirement	Minimum number of required quantity in any two of last seven years
1.	Automatic Rain gauge Sensor (ARG)	44	22

2.	Radar Water Level Sensor	58	29
3.	Air Temperature and Humidity Sensor	3	5
4.	Wind Speed and Direction Sensor	3	5
5.	Atmospheric Pressure Sensor	3	5
6.	Solar Radiation Sensor	3	5
7.	Automated pan evaporimeter Equipment	3	5
8.	2 AI Data loggers with Satellite / GSM / GPRS telemetry port	98	48
9.	8 AI Data loggers with Satellite / GSM / GPRS telemetry port	7	5
10.	INSAT/Satellite transmitter	105	54
11.	GPRS / GSM modem	105	54
12.	Gate Position Sensor (Shaft Encoder Type)	27	14

III- The bidder should have after sales support in the region (within a radius of 500 km from the State Capital). If bidder does not have any after sales support office within 500 km from state Capital at the time of bidding, he shall require to be establish the same within one month after successful award of contract

IV- Even though the bidders meet the above qualifying criteria, they are subject to be disqualified if they have made misleading or false representations in the forms, statements and attachments submitted in proof of the qualification requirements; and/or record of poor performance such as, not properly completing the contract, inordinate delays in completion, litigation history, or financial failures etc.

FINANCIAL PART

2. Margin of Preference (ITB 37) – Not Applicable

3. Evaluation (ITB 30, 31, and 34)

3.1 Evaluation Criteria (ITB 34.5)

The Purchaser shall use the criteria and methodologies listed in this Section to evaluate Bids. By applying the criteria and methodologies, the Purchaser shall determine the substantially responsive lowest-evaluated bid.

The Purchaser's evaluation of a bid may take into account, in addition to the Bid Price quoted in accordance with ITB Clause 14.8, one or more of the following factors as specified in ITB Sub-Clause 34.1 (f) and in BDS referring to ITB 34.5, using the following criteria and methodologies. :

- (a) **The Purchaser's evaluation of a bid will take into account the Bid Price quoted in accordance with ITB Clause 14.8 including 5 years warranty & Operation and Maintenance period.**

3.2. Multiple Contracts (ITB 34.3)

Not Applicable.

Section IV – Bidding Forms

1A. LETTER OF BID– TECHNICAL PART

The Bidder must prepare the Letter of Bid on stationery with its letterhead clearly showing the Bidder's complete name and address.

Note: All italicized text is for use in preparing these forms and shall be deleted from the final products.

No alterations to the text except as provided in ITB20.2, shall be permitted and no substitutions shall be accepted except as provided in ITB 12.]

Date: *[insert date (as day, month and year) of Bid Submission]*

NCB No.: *[insert number of bidding process]*

Invitation for Bid No.: *[insert No of IFB]*

Alternative No.: *[insert identification No if this is a Bid for an alternative]*

To:

The Executive Engineer

Burdwan Investigation & Planning Division

Irrigation & Waterways Directorate Govt. of West Bengal

PurtaBhawan, 3rd Floor Purba Burdwan-713103, West Bengal

We, the undersigned, declare that:

- (a) We have examined and have no reservations to the Bidding Documents, including Addenda No. issued in accordance with ITB 8: *[insert the number and issuing date of each Addenda]*;
- (b) We meet the eligibility requirements and have no conflict of interest in accordance with ITB 4;
- (c) We havenot been suspended nor declared ineligible by the Purchaser based on execution of a Bid Securing Declaration in the Purchaser's country in accordance with ITB 4.6;
- (d) We offer to supply in conformity with the Bidding Documents and in accordance with the Delivery Schedules specified in the Schedule of Requirements the following Goods and Related Services *[insert a brief description of the Goods and Related Services]*;
- (e) Our bid shall be valid for the period of time specified in ITB Sub-Clause 18.1, from the date fixed for the bid submission deadline in accordance with ITB Sub-Clause 22, and it shall remain binding upon us and may be accepted at any time before the expiration of that period;
- (f) If our bid is accepted, we commit to obtain a performance security in accordance with the Bidding Documents;

- (g) We are not participating, as a Bidder or as a sub-Contractor, in more than one bid in this bidding process in accordance with ITB 4.2(e), other than alternative bids submitted in accordance with ITB 13;
- (h) We, along with any of our sub-Contractors, suppliers, consultants, manufacturers, or service providers for any part of the Contract, are not subject to, and not controlled by any entity or individual that is subject to, a temporary suspension or a debarment imposed by the World Bank Group or a debarment imposed by the World Bank Group in accordance with the Agreement for Mutual Enforcement of Debarment Decisions between the World Bank and other development banks. Further, we are not ineligible under the Purchaser's Country laws or official regulations or pursuant to a decision of the United Nations Security Council;
- (i) We are not a government owned entity/ We are a government owned entity but meet the requirements of ITB 4.5;¹
- (j) We understand that this bid, together with your written acceptance thereof included in your notification of award, shall constitute a binding Contract between us, until a formal Contract is prepared and executed;
- (k) We understand that you are not bound to accept the lowest evaluated bid or any other bid that you may receive;
- (l) We hereby certify that we have taken steps to ensure that no person acting for us or on our behalf will engage in any type of fraud and corruption; and
- (m) We undertake that, in competing for (and, if the award is made to us, in executing) the above Contract, we will strictly observe the laws against fraud and corruption in force in India namely, "Prevention of Corruption Act 1988."

Name of the Bidder ***[insert complete name of person signing the Bid]***

Name of the person duly authorized to sign the Bid on behalf of the Bidder** ***[insert complete name of person duly authorized to sign the Bid]***

Title of the person signing the Bid ***[insert complete title of the person signing the Bid]***

Signature of the person named above ***[insert signature of person whose name and capacity are shown above]***

Date signed ***[insert date of signing]*** day of ***[insert month]***, ***[insert year]***

** : Person signing the Bid shall have the power of attorney given by the Bidder to be attached with the Bid Schedules.

¹ Bidder to use as appropriate

1B. LETTER OF BID- FINANCIAL PART

The Bidder must prepare the Letter of Bid on stationery with its letterhead clearly showing the Bidder's complete name and address.

Note: All italicized text is for use in preparing these forms and shall be deleted from the final products.

No alterations to the text except as provided in ITB 20.2, shall be permitted and no substitutions shall be accepted except as provided in ITB 12.]

Date: *[insert date (as day, month and year) of Bid Submission]*

NCB No.: *[insert number of bidding process]*

Invitation for Bid No.: *[insert No of IFB]*

Alternative No.: *[insert identification No if this is a Bid for an alternative]*

To:

The Executive Engineer

Burdwan Investigation & Planning Division

Irrigation & Waterways Directorate Govt. of West Bengal

, PurtaBhawan, 3rd Floor Purba Burdwan-713103, West Bengal

We, the undersigned Bidder, hereby submit the second part of our Bid, the Financial Part. In submitting our Financial Part we make the following additional declarations:

(a) Our bid shall be valid for the period of time specified in ITB Sub-Clause 18.1, from the date fixed for the bid submission deadline in accordance with ITB Sub-Clause 22, and it shall remain binding upon us and may be accepted at any time before the expiration of that period;

(b) The total price of our Bid, excluding any discounts offered in item (c) below, is:

In case of only one lot, total price of the Bid **[insert the total price of the bid in words and figures];**

In case of multiple lots, total price of each lot [insert the total price of each lot in words and figures];

In case of multiple lots, total price of all lots (sum of all lots) [insert the total price of all lots in words and figures];

(c) The discounts offered and the methodology for their application are:

(i) The discounts offered are: [Specify in detail each discount offered.]

(ii) The exact method of calculations to determine the net price after application of discounts is shown below: [Specify in detail the method that shall be used to apply the discounts]; Discounts.

- (d) The following commissions, gratuities, or fees have been paid or are to be paid with respect to the bidding process or execution of the Contract: *[insert complete name of each Recipient, its full address, the reason for which each commission or gratuity was paid and the amount and currency of each such commission or gratuity]*

Name of Recipient	Address	Reason	Amount
_____	_____	_____	_____
_____	_____	_____	_____
_____	_____	_____	_____
_____	_____	_____	_____

(If none has been paid or is to be paid, indicate “none.”)

- (e) We understand that this bid, together with your written acceptance thereof included in your notification of award, shall constitute a binding Contract between us, until a formal Contract is prepared and executed.

Name of the Bidder *[insert complete name of person signing the Bid]*

Name of the person duly authorized to sign the Bid on behalf of the Bidder** *[insert complete name of person duly authorized to sign the Bid]*

Title of the person signing the Bid *[insert complete title of the person signing the Bid]*

Signature of the person named above *[insert signature of person whose name and capacity are shown above]*

Date signed *[insert date of signing]* day of *[insert month]*, *[insert year]*

** : Person signing the Bid shall have the power of attorney given by the Bidder to be attached with the Bid Schedules.

2. BIDDER INFORMATION FORM

[The Bidder shall fill in this Form in accordance with the instructions indicated below. No alterations to its format shall be permitted and no substitutions shall be accepted.]

Date: *[insert date (as day, month and year) of Bid Submission]*

NCB No.: *[insert number of bidding process]*

Page _____ of _____ pages

1. Bidder's Legal Name <i>[insert Bidder's legal name]</i>
2. Bidder's actual or intended Country of Registration: <i>[insert actual or intended Country of Registration]</i>
3. Bidder's Year of Registration: <i>[insert Bidder's year of registration]</i>
4. Bidder's Legal Address in Country of Registration: <i>[insert Bidder's legal address in country of registration]</i>
5. Bidder's Authorized Representative Information Name: <i>[insert Authorized Representative's name]</i> Address: <i>[insert Authorized Representative's Address]</i> Telephone/Fax numbers: <i>[insert Authorized Representative's telephone/fax numbers]</i> Email Address: <i>[insert Authorized Representative's email address]</i>
6. Attached are copies of original documents of: <i>[check the box(es) of the attached original documents]</i> <input type="checkbox"/> Articles of Incorporation or Registration of firm named in 1, above, in accordance with ITB Sub-Clauses 4.3. <input type="checkbox"/> In case of government owned entity from the Purchaser's country, documents establishing legal and financial autonomy and compliance with commercial law and not dependent agency of borrower or sub-borrower or purchaser, in accordance with ITB Sub-Clause 4.5. <input type="checkbox"/> Included are the organizational chart, a list of Board of Directors, and the beneficial ownership

3. FORM OF AFFIDAVIT FOR CORRECTNESS OF INFORMATION AND DOCUMENTS SUBMITTED WITH BID

[Reference ITB 20.2]

[This affidavit should be on a non-judicial stamp paper of Rs.10/- and shall be attested by Magistrate/ Sub-Judge/ Notary Public]

I, *(name of the authorised representative of the Bidder)* solemnly affirm and state as under:

1. I hereby certify that all the information and documents furnished with the Bid submitted online in response to IFB number date issued by *(authority inviting bids)* for *(name and identification of Goods & Related Services)* are true and correct.
2. *I hereby certify that I have been authorised by *(the Bidder)* to sign on their behalf, the Bid mentioned in paragraph 1 above.

Deponent

Place:

Date:

**This sub-paragraph is not applicable if the Bidder is an individual and is signing the Bid on his own behalf.*

4. Joint Venture Partner Information Form

[The Bidder shall fill in this Form in accordance with the instructions indicated below].

Date: *[insert date (as day, month and year) of Bid Submission]*

NCB No.: *[insert number of bidding process]*

Page _____ of _____ pages

1. Bidder's Legal Name: <i>[insert Bidder's legal name]</i>
2. JV's Party legal name: <i>[insert JV's Party legal name]</i>
3. JV's Party Country of Registration: <i>[insert JV's Party country of registration]</i>
4. JV's Party Year of Registration: <i>[insert JV's Part year of registration]</i>
5. JV's Party Legal Address in Country of Registration: <i>[insert JV's Party legal address in country of registration]</i>
6. JV's Party Authorized Representative Information Name: <i>[insert name of JV's Party authorized representative]</i> Address: <i>[insert address of JV's Party authorized representative]</i> Telephone/Fax numbers: <i>[insert telephone/fax numbers of JV's Party authorized representative]</i> Email Address: <i>[insert email address of JV's Party authorized representative]</i>
7. Attached are copies of original documents of: <i>[check the box(es) of the attached original documents]</i> <input type="checkbox"/> Articles of Incorporation or Registration of firm named in 2, above, in accordance with ITB Sub-Clauses 4.1 and 4.2. <input type="checkbox"/> In case of government owned entity from the Purchaser's country, documents establishing legal and financial autonomy and compliance with commercial law, in accordance with ITB Sub-Clause 4.5.

5. Price Schedule Forms

*[The Bidder shall fill in these Price Schedule Forms in accordance with the instructions indicated. The list of line items in column 1 of the **Price Schedules** shall coincide with the List of Goods and Related Services specified by the Purchaser in the Schedule of Requirements.]*

Note: *Bidders are required to populate the Excel file containing the BOQ (uploaded along with the NIQ) and upload it in the requisite financial folder for submission of the bid*

A. PRICE SCHEDULE FOR SUPPLY OF GOODS AS PER SCHEDULE OF REQUIREMENT

							Date: _____ NCB No: _____ Alternative No: _____ Page No. _____ of _____			
Name of the Bidder/ Bidding Firm / Company :							Tender Inviting Authority: Name of Work: Contract No: WBIW/NHP/RTDAS/IFB-01/2019-20 Name of the Bidder/ Bidding Firm / Company :			
PRICE SCHEDULE (DOMESTIC TENDERS - RATES ARE TO GIVEN IN RUPEES (INR) ONLY) (This BOQ template must not be modified/replaced by the bidder and the same should be uploaded after filling the relevant columns, else the bidder is liable to be rejected for this tender. Bidders are allowed to enter the Bidder Name and Values only)										
1	2	3	4	5	6	7	8	9	10	11
Line Item No	Description of Goods	Country of Origin	Delivery Date	Quantity	Unit	Unit price EXW	Total EXW price per line item (Col. 5x7)	Price per line item for inland transportation, insurance and other services required to convey the Goods to their final destination (ITB 14.8 (a)(iii))	Total GST and other taxes payable per item if Contract is awarded (in accordance with ITB 14.8(a)(ii))	Total Price per line item excluding GST (Col. 8+9)
1.	(ARG) RTDAS Station of I&WDWEST BENGAL									
1a	Automated Rain Gauge (ARG) Stations Equipment set with necessary hardware as per technical specifications		4 months from date of signing of Contract	41	Nos.					
1b	Data Logger with 2 AI channels with INSAT, GSM& GPRS based telemetry including antenna and all necessary equipment for data transmission as per technical specifications.		4 months from date of signing of Contract	41	Nos.					

1c	Solar panel with all connectors, cables and conduit for cables as per technical specifications.		4 months from date of signing of Contract	41	Nos.					
1d	Battery, charger regulator with all interconnecting connectors, cables for DCP as per technical specifications		4 months from date of signing of Contract	41	Nos.					
1e	NEMA4X OR Equivalent Enclosure box to suit master unit equipment with locking, other ancillary equipment, fittings earthing, lightning arrestor with all connectors, cables and conduit for cables, mast to mount DCP, sensor mount complete as per technical specifications		4 months from date of signing of Contract	41	Nos.					
2.	(AWS) RTDAS Station of I&WD WEST BENGAL									
2a	Automated Rainfall Stations (ARS) Sensor Equipment set necessary hardware as per technical specifications.		4 months from date of signing of Contract	03	Nos.					
2b	Air Temperature & Relative Humidity sensor, cable with Radiation shield, Equipment set necessary hardware as per technical specifications		4 months from date of signing of Contract	03	Nos.					
2c	Wind speed & wind direction sensor and cable set necessary hardware as per technical specifications		4 months from date of signing of Contract	03	Nos.					
2d	Atmospheric Pressure sensor and cable set necessary hardware as per technical specifications		4 months from date of signing of Contract	03	Nos.					
2e	Solar Radiation sensor and cable set necessary hardware as per technical specifications		4 months from date of signing of Contract	03	Nos.					

2f	Automated pan evaporimeter Equipment set necessary hardware as per technical specifications		4 months from date of signing of Contract	03	Nos.					
2g	Data Logger with 8 AI channels with INSAT, GSM & GPRS based telemetry including antenna and all necessary equipment for data transmission as per technical specifications.		4 months from date of signing of Contract	03	Nos.					
2h	Solar panel with all connectors, cables and conduit as per technical specifications		4 months from date of signing of Contract	03	Nos.					
2i	Battery, charger regulator with all interconnecting connectors, cables for DCP as per technical specifications		4 months from date of signing of Contract	03	Nos.					
2j	NEMA4X OR Equivalent Enclosure box to suit master unit equipment with locking, other ancillary equipment, fittings earthing, lightning arrestor with all connectors, cables and conduit for cables, 10mts tower with guy rope to mount DCP, sensor mount complete as per technical specifications		4 months from date of signing of Contract	03	Nos.					
3.	(AWLR) RTDAS Station of I&WD WEST BENGAL									
3a	Automated Water Level Recorder (non-contact RADAR) for River /Canal/Reservoir having 35m range with all necessary hardware as per technical specifications		4 months from date of signing of Contract	56	Nos.					
3b	Data Logger with 2 AI channels with INSAT, GSM & GPRS based telemetry including antenna and all necessary equipment for data transmission as per technical specifications.		4 months from date of signing of Contract	56	Nos.					

3c	Solar panel with all connectors, cables and conduit as per technical specifications		4 months from date of signing of Contract	56	Nos.					
3d	Battery, charger regulator with all interconnecting connectors, cables for DCP as per technical specifications		4 months from date of signing of Contract	56	Nos.					
3e	NEMA4X OR Equivalent Enclosure box to suit master unit equipment with locking, other ancillary equipment, fittings earthing, lightening arrestor with all connectors, cables and conduit for cables, mast to mount DCP, sensor mount complete as per technical specifications		4 months from date of signing of Contract	56	Nos.					
4.	(AWLR+ Gate Sensors) RTDAS Station of I&WD WEST BENGALHinglow Reservoir (Hinglow Dam)									
4a	Automated Water Level Recorder(non-contactRADAR) for River /Canal/Reservoir having 35m range with all necessary hardware as per technical specifications		4 months from date of signing of Contract	01.	Nos.					
4b	Shaft Encoder based rotary position Type Gate Position Sensors for indication and monitoring of Spillway gates, Intake Gates, Silt flushing gates including cabling& conduits as per technical specifications		4 months from date of signing of Contract	11	Nos.					
4c	Data Logger with 8 AI channels with INSAT, GSM &GPRS based telemetry including antenna and all necessary equipment for data transmission as per technical specifications		4 months from date of signing of Contract	02	Nos.					
4d	Solar panel with all connectors, cables and conduit as per technical specifications		4 months from date of signing of Contract	02	Nos.					

4e	Battery, charger regulator with all interconnecting connectors, cables for DCP as per technical specifications		4 months from date of signing of Contract	02	Nos.					
4f	NEMA4X OR Equivalent Enclosure box to suit master unit equipment with locking, other ancillary equipment, fittings earthing, lightening arrestor with all connectors, cables and conduit for cables, mast to mount DCP, sensor mount complete as per technical specifications		4 months from date of signing of Contract	02	Nos.					
4g	LED Running Text Display unit to be integrated with RTDAS datalogger to display the Hydro-met Data string in running text for indoor and outdoor application with cable, fixing arrangement, accessories complete as technical per specifications		4 months from date of signing of Contract	01	Nos.					
5.	(AWLR+ Gate Sensors) RTDAS Station of I&WD WEST BENGAL Kangsabati Reservoir (Mukutmanipur Dam)									
5a	Automated Water Level Recorder (non-contact RADAR) for River/Canal/Reservoir having 0-35m range with all necessary hardware as per technical specifications		4 months from date of signing of Contract	01	Nos.					
5b	Shaft Encoder based rotary position Type Gate Position Sensors for indication and monitoring of Spillway gates/Intake Gates/ Silt flushing gates including cabling & integration with datalogger as per technical specifications.		4 months from date of signing of Contract	16	Nos.					
5c	Data Logger with 2 AI channels with INSAT, GSM & GPRS based telemetry including antenna and all necessary equipment for data transmission as per technical specifications.		4 months from date of signing of Contract	01	Nos.					
5d	Data Logger with 8 AI channels with INSAT, GSM & GPRS based telemetry including antenna and all necessary equipment for data transmission as per		4 months from date of signing of Contract	02	Nos.					

	technical specifications.									
5e	Solar panel with all connectors, cables and conduit as per technical specifications		4 months from date of signing of Contract	03	Nos.					
5f	Battery, charger regulator with all interconnecting connectors, cables for DCP as per technical specifications		4 months from date of signing of Contract	03	Nos.					
5g	NEMA4X OR Equivalent Enclosure box to suit master unit equipment with locking, other ancillary equipment, fittings earthing, lightening arrestor with all connectors, cables and conduit for cables, mast to mount DCP, sensor mount complete as per technical specifications		4 months from date of signing of Contract	03	Nos.					
5h	LED Running Text Display unit to be integrated with RTDAS datalogger to display the Hydro-met Data string in running text for indoor and outdoor application with cable, fixing arrangement, accessories complete as technical per specifications		4 months from date of signing of Contract	01	Nos.					
6	Set of Data Center Equipment to collect and store the data received from proposed DCPs established across the state of West Bengal to the central data center located at Bidhannagar, Kolkata									
6a	Server along with server rack, Monitor and 3 KVA online UPS as per technical specifications		4 months from date of signing of Contract	1	Set					
6b	Computer Node (Workstation) along with Monitor and necessary accessories as per technical specifications		4 months from date of signing of Contract	1	Set					
6c	IT Hardware which includes required Static IP, Router, Switch, firewall system and A3 colour printer as per technical specifications and necessary accessories.		4 months from date of signing of Contract	1	Set					

6d	55" LED Display System as per technical specifications		4 months from date of signing of Contract	1	Set					
6e	High speed synchronous internet connection (min. 8 mbps upload and 8 mbps download) for five years.		4 months from date of signing of Contract	1	Set					
6f	GSM & GPRS data receiving system with all ancillary equipment, as per technical specifications.		4 months from date of signing of Contract	1	Set					
						TOTALPRICE Rs. (A)				
						GST Rs.				

Name of Bidder [insert complete name of Bidder] Signature of Bidder [signature of person signing the Bid] Date [insert date]

B. PRICE AND COMPLETION SCHEDULE - RELATED SERVICES

	Prices in Rs	Date: _____					
		NCB No: _____					
		Alternative No: _____					
		Page N ^o _____ of _____					
Tender Inviting Authority:							
Name of Work:							
Contract No: WBIW/NHP/RTDAS/IFB-01/2019-20							
Name of the Bidder/ Bidding Firm / Company :							
PRICE SCHEDULE (DOMESTIC TENDERS - RATES ARE TO GIVEN IN RUPEES (INR) ONLY) (This BOQ template must not be modified/replaced by the bidder and the same should be uploaded after filling the relevant columns, else the bidder is liable to be rejected for this tender. Bidders are allowed to enter the Bidder Name and Values only)							
1	2	3	4	5	6	7	8
Service No	Description of Services	Delivery Date at place of Final destination	Quantity	Unit	Unit price (excluding GST)	Total GST and other taxes payable per item if Contract is awarded (in accordance with ITB 14.8(a)(ii))	Total Price per Service excluding GST (Col. 4*6)
	Installation of the systems including civil works which also include Performance and supervision of the on-site assembly and/or start-up of the supplied Goods						
S-1	(ARG) RTDAS Station of I&WD WEST BENGAL						
S- 1a	Installation testing & Commissioning of Automated Rain Gauge (ARG) Stations Equipment set with necessary hardware including	09 months from date of signing	41	Nos.			

	associated civil works as per technical specifications.	of Contract					
S-1b	Installation testing & Commissioning of Data Logger with 2 AI channels with INSAT, GSM & GPRS based telemetry including antenna and all necessary equipment for data transmission as per technical specifications.	09 months from date of signing of Contract	41.	Nos.			
S-1c	Installation testing & Commissioning of solar panel with all connectors, cables and conduit as per technical specifications	09 months from date of signing of Contract	41	Nos.			
S-1d	Installation testing & commissioning of Battery, charger regulator with all interconnecting connectors, cables for DCP as per technical specifications	09 months from date of signing of Contract	41.	Nos.			
S-1e	Installation testing & commissioning of NEMA4X OR Equivalent Enclosure box to suit master unit equipment with locking, other ancillary equipment, fittings earthing, lightning arrestor with all connectors, cables and conduit for cables, mast to mount DCP, sensor mount complete as per technical specifications	09 months from date of signing of Contract	41	Nos.			
S-1f	Installation of Chain link Fencing (5m*5m) *2m including associated civil works for independent ARG sensors (line item no. S-1) only, along with lockable gates for external protection of ARG and DCP at remote stations as mentioned in Schedule of Requirements.	09 months from date of signing of Contract	41	Nos.			

S-2	(AWS) RTDAS Station of I&WD WEST BENGAL						
	AWS includes below equipment's						
S-2a	Installation testing & Commissioning of Automated Rainfall Stations (ARS) Sensor Equipment set necessary hardware as per technical specifications.	09 months from date of signing of Contract	03	Nos.			
S-2b	Installation testing & Commissioning of Air Temperature & Relative Humidity sensor, cable with Radiation shield, Equipment set necessary hardware as per technical specifications	09 months from date of signing of Contract	03	Nos.			
S-2c	Installation testing & Commissioning of Wind speed & wind direction sensor and cable set necessary hardware as per technical specifications	09 months from date of signing of Contract	03	Nos.			
S-2d	Installation testing & Commissioning of Atmospheric Pressure sensor and cable set necessary hardware as per technical specifications	09 months from date of signing of Contract	03	Nos.			
S-2e	Installation testing & Commissioning of Solar Radiation sensor and cable set necessary hardware as per technical specifications	09 months from date of signing of Contract	03	Nos.			
S-2f	Installation testing & Commissioning of Automated pan evaporimeter Equipment set necessary hardware as per technical specifications	09 months from date of signing of Contract	03	Nos.			

S-2g	Installation testing & Commissioning of Data Logger with 8 AI channels with INSAT, GSM & GPRS based telemetry including antenna and all necessary equipment for data transmission as per technical specifications.	09 months from date of signing of Contract	03	Nos.			
S-2 g	Installation testing & Commissioning of solar panel with all connectors, cables and conduit for cables as per technical specifications	09 months from date of signing of Contract	03	Nos.			
S-2 i	Installation testing & commissioning of Battery, charger regulator with all interconnecting connectors, cables for DCP as per technical specifications	09 months from date of signing of Contract	03	Nos.			
S-2 j	Installation testing & commissioning of NEMA4X OR Equivalent Enclosure box to suit master unit equipment with locking, other ancillary equipment, fittings earthing, lightning arrester with all connectors, cables and conduit for cables, 10mts tower with guy rope to mount DCP, sensor mount complete as per technical specifications	09 months from date of signing of Contract	03	Nos.			
S-2k	Installation of Chain Link Fencing (10m*10m)*2m including associated civil works for independent AWS stations (line item no. S-2) only, along with lockable gates for external protection of AWS and DCP at remote stations as mentioned in Schedule of Requirements.	09 months from date of signing of Contract	03	Nos.			
S-3	(AWLR) RTDAS Station of I&WD WEST BENGAL						

S-3a	Installation testing & Commissioning of Automated Water Level Recorder (non-contact RADAR) for River /Canal/Reservoir having 35m range with all necessary hardware including associated civil works & mounting arrangements as per technical specifications.	09 months from date of signing of Contract	56	Nos.			
S-3b	Installation testing & Commissioning of Data Logger with 2 AI channels with INSAT, GSM & GPRS based telemetry including antenna and all necessary equipment for data transmission as per technical specifications.	09 months from date of signing of Contract	56	Nos.			
S-3 c	Installation testing & Commissioning of solar panel with all connectors, cables and conduit as per technical specifications	09 months from date of signing of Contract	56	Nos.			
S-3 d	Installation testing & commissioning of Battery, charger regulator with all interconnecting connectors, cables for DCP as per technical specifications	09 months from date of signing of Contract	56	Nos.			
S-3 e	Installation testing & commissioning of NEMA4X OR Equivalent Enclosure box to suit master unit equipment with locking, other ancillary equipment, fittings earthing, lightning arrestor with all connectors, cables and conduit for cables, mast to mount DCP, sensor mount complete as per technical specifications	09 months from date of signing of Contract	56	Nos.			
S-4	(AWLR+ Gate Sensors) RTDAS Station of I&WD WEST BENGALHinglow Reservoir (Hinglow Dam)						
S-4a	Installation testing & Commissioning of Automated Water Level Recorder (non-contact	09 months from date of signing	01	Nos.			

	RADAR) for River /Canal/Reservoir having 35m range with all necessary hardware including associated civil works& mounting arrangements as per technical specifications.	of Contract					
S-4b	Installation testing & Commissioning of Shaft Encoder based rotary position type, Gate Position Sensors for indication and monitoring of Spillway gates, Intake Gates, Silt flushing gates including cabling as per technical specifications.	09 months from date of signing of Contract	11	Nos.			
S-4d	Installation testing & Commissioning of Data Logger 8 AI channels with INSAT, GSM & GPRS based telemetry including antenna and all necessary equipment for data transmission as per technical specifications.	09 months from date of signing of Contract	02	Nos.			
S-4e	Installation testing & Commissioning of solar panel, charger regulator, batteries, earthing&lightening arrestor with all connectors, NEMA4X box to suit master unit with locking, cables and conduit for cables, mast & associated Civil works to mount DCP as per technical specifications.	09 months from date of signing of Contract	02	Nos.			
S-4f	Installation testing & commissioning of Battery, charger regulator with all interconnecting connectors, cables for DCP as per technical specifications	09 months from date of signing of Contract	02	Nos.			
S-4g	Installation testing & commissioning of NEMA4X OR Equivalent Enclosure box to suit master unit equipment with locking, other ancillary equipment, fittings earthing, lightening arrestor with all connectors, cables and conduit for cables, mast to mount DCP, sensor mount	09 months from date of signing of Contract	02	Nos.			

	complete as per technical specifications						
S-4h	Installation, Testing & Commissioning of LED Running Text Display unit to be integrated with RTDAS datalogger to display the Hydro-met Data string in running text for indoor and outdoor application with cable, fixing arrangement, accessories complete as technical per specifications	09 months from date of signing of Contract	01	Nos.			
S-5	(AWLR+ Gate Sensors) RTDAS Station of I&WD WEST BENGAL Kangsabati Reservoir (Mukutmanipur Dam)						
S-5a	Installation testing & Commissioning of Automated Water Level Recorder (non-contact RADAR) for River /Canal/Reservoir having 35m range with all necessary hardware including associated civil works& mounting arrangements as per technical specifications.	09 months from date of signing of Contract	01	Nos.			
S-5b	Installation testing & Commissioning of Shaft Encoder based rotary position type, Gate Position Sensors for indication and monitoring of Spillway gates, Intake Gates, Silt flushing gates including cabling as per technical specifications.	09 months from date of signing of Contract	16	Nos.			
S-5c	Installation testing & Commissioning of Data Logger with 2 AI channels with INSAT, GSM & GPRS based telemetry including antenna and all necessary equipment for data transmission as per technical specifications.	09 months from date of signing of Contract	01	Nos.			
S-5d	Installation testing & Commissioning of Data Logger 8 AI channels with INSAT, GSM & GPRS based telemetry including antenna and all necessary equipment for data transmission as per technical specifications.	09 months from date of signing of Contract	02	Nos.			

S-5e	Installation testing & Commissioning of solar panel, charger regulator, batteries, earthing&lightening arrestor with all connectors, NEMA4X box to suit master unit with locking, cables and conduit for cables, mast & associated Civil works to mount DCP as per technical specifications.	09 months from date of signing of Contract	03	Nos.			
S-5f	Installation testing & commissioning of Battery, charger regulator with all interconnecting connectors, cables for DCP as per technical specifications	09 months from date of signing of Contract	03	Nos.			
S-5g	Installation testing & commissioning of NEMA4X OR Equivalent Enclosure box to suit master unit equipment with locking, other ancillary equipment, fittings earthing, lightning arrestor with all connectors, cables and conduit for cables, mast to mount DCP, sensor mount complete as per technical specifications	09 months from date of signing of Contract	03	Nos.			
S-5h	Installation, Testing & Commissioning of LED Running Text Display unit to be integrated with RTDAS datalogger to display the Hydro-met Data string in running text for indoor and outdoor application with cable, fixing arrangement, accessories complete as technical per specifications	09 months from date of signing of Contract	01	Nos.			
S-6	Set of Data Center Equipment to collect and store the data received from proposed DCPs established across the state of West Bengal to the central data center located at Bidhannagar, Kolkata						

S-6a	Installation testing & Commissioning of Server for data reception and storage along with server rack, Monitor and 3 KVA online UPS as per technical specifications	6 months from date of signing of Contract	01	Nos.			
S-6b	Installation, Testing & Commissioning of Computer Node (Workstation) along with Monitor and necessary accessories as per technical specifications	6 months from date of signing of Contract	01	Nos.			
S-6c	Installation testing & Commissioning of IT Hardware which includes required Static IP, Router, Switch, firewall system and A3 Size colour printer and necessary accessories as per technical specifications	6 months from date of signing of Contract	01	Nos.			
S-6d	Installation testing & Commissioning of 55" LED Display System as per technical specifications	6 months from date of signing of Contract	01	Nos.			
S-6e	Installation testing & Commissioning for high speed synchronous internet connection (min. 8 mbps upload and 8 mbps download) for Five years	6 months from date of signing of Contract	01	Nos.			
S-6f	Installation testing & Commissioning of GSM & GPRS data receiving system with all ancillary equipments as per technical specifications	6 months from date of signing of Contract	01	Nos.			

S-7	<p>Operation & Maintenance and Comprehensive Warranty for RTDAS with Telemetry system as specified in Schedule of Requirement along with accessories, installed at designated locations within West Bengal and Data Center equipments after final acceptance of RTDAS systems. This includes replacement of material / goods& consumable as & when required at bidders cost. The cost of Communication for GSM & GPRS telemetry for data transmission shall be borne by bidder. The license fee as applicable for DOT for INSAT transmission shall be borne by purchaser.</p> <p><u>This also includes availability of minimum One Service Engineer shall be placed at State Data Center for Operation and Maintenance of RTDAS system with Telemetry for entire warranty period of 5 years (refer GCC clause 28.3).</u></p>	Continuou s activity for five years after successful commissio ning and Final acceptance certificate of RTDAS	1	Job			
S-8	<p>Training of the purchaser's personnel at the supplier's plant and/or/onsite in assembly, startup, operation, maintenance and/or repair of the supplied goods. Course topics will include sensor calibration, data logger configuration, data downloading, data retrieval, collection, Trouble shooting, processing maintenance requirements and procedure for equipment configuration, installation, site testing and commissioning including training kit containing course material in soft and hard copies as per technical specification</p>	Continuou s activity	8	Nos.			
					Total Price Rs. (B)		

		GST Rs.		
		Total Bid Price (A + B) Rs.		
Grand Total of GST	Quoted GST in Words	XXXX	XXXX	
Grand Total	Quoted Rate in Words	XXXX		XXXX

Name of Bidder *[insert complete name of Bidder]* Signature of Bidder *[signature of person signing the Bid]* Date *[insert date]*

6. Forms of Bid Security

Form of Bid Security - Bank Guarantee

[Guarantor letterhead or SWIFT identifier code]

Bank Guarantee No.....*[insert guarantee reference number]*

Date.....*[insert date of issue of the guarantee]*

WHEREAS, _____ *[name of Bidder]*² (hereinafter called "the Applicant") has submitted his Bid dated _____ *[date]* or will submit his Bid for the supply of _____ *[name of Contract]* (hereinafter called "the Bid") under Invitation for Bids No.....*[insert number]* (hereinafter called "the IFB")

KNOW ALL PEOPLE by these presents that We _____ *[name of bank]* of _____ *[name of country]* having our registered office at _____ (hereinafter called "the Bank") are bound unto _____ *[name of Purchaser]* (hereinafter called "the Purchaser ") in the sum of _____³ for which payment well and truly to be made to the said Purchaser the Bank binds itself, his successors and assigns by these presents.

SEALED with the Common Seal of the said Bank this _____ day of _____ 20____.

THE CONDITIONS of this obligation are:

- (1) If after Bid opening the Applicant (a) withdraws his bid during the period of Bid validity specified in the Letter of Bid; or (b) does not accept the correction of the Bid Price pursuant to ITB 35;

or

- (2) If the Applicant having been notified of the acceptance of his bid by the Purchaser during the period of Bid validity:
 - (a) fails or refuses to execute the Contract Agreement in accordance with the Instructions to Bidders, if required; or
 - (b) fails or refuses to furnish the Performance Security, in accordance with the Instruction to Bidders.

²*In the case of a JV, the bidder should be stated as "a Joint Venture consisting of, and".*

³*The Applicant should insert the amount of the guarantee in words and figures denominated in Indian Rupees. This figure should be the same as shown in Clause 19.1 of the Instructions to Bidders.*

we undertake to pay to the Purchaser up to the above amount upon receipt of his first written demand, without the Purchaser having to substantiate his demand, provided that in his demand the Purchaser will note that the amount claimed by him is due to him owing to the occurrence of one or any of the four conditions, specifying the occurred condition or conditions.

This Guarantee will remain in force up to and including the date _____⁴ days after the deadline for submission of Bids as such deadline is stated in the Instructions to Bidders or as it may be extended by the Purchaser, notice of which extension(s) to the Bank is hereby waived. Any demand in respect of this guarantee should reach the Bank not later than the above date.

DATE _____ SIGNATURE OF THE BANK _____

WITNESS _____ SEAL _____

[signature, name, and address]

Note: All italicized text (including footnotes) is for use in preparing this form and shall be deleted from the final product.

⁴45 days after the end of the validity period of the Bid.

7. MANUFACTURER'S AUTHORIZATION

[The Bidder shall require the Manufacturer to fill in this Form in accordance with the instructions indicated. This letter of authorization should be on the letterhead of the Manufacturer and should be signed by a person with the proper authority to sign documents that are legally binding on the Manufacturer. The Bidder shall include it in its bid, if so indicated in the BDS.]

Date: *[insert date (as day, month and year) of Bid Submission]*
NCB No.: *[insert number of bidding process]*
Alternative No.: *[insert identification No if this is a Bid for an alternative]*

To:
The Executive Engineer
Burdwan Investigation & Planning Division
Irrigation & Waterways Directorate Govt. of West Bengal
PurtaBhawan, 3rd Floor Purba Burdwan-713103, West Bengal

WHEREAS

We *[insert complete name of Manufacturer]*, who are official manufacturers of *[insert type of goods manufactured]*, having factories at *[insert full address of Manufacturer's factories]*, do hereby authorize *[insert complete name of Bidder]* to submit a bid the purpose of which is to provide the following Goods, manufactured by us *[insert name and or brief description of the Goods]*, and to subsequently negotiate and sign the Contract against the above IFB.

We hereby extend our full guarantee and warranty in accordance with Clause 28 of the General Conditions of Contract, with respect to the Goods offered by the above firm against this IFB.

We as a manufacturer of *[insert type of goods manufactured]* confirm to provide the spare & service support for a minimum period of 10 years after commissioning

Signed: *[insert signature(s) of authorized representative(s) of the Manufacturer]*

Name: *[insert complete name(s) of authorized representative(s) of the Manufacturer]*

Title: *[insert title]*

Duly authorized to sign this Authorization on behalf of: *[insert complete name of Bidder]*

Dated on _____ day of _____, _____ *[insert date of signing]*

Note – Modify this format suitably in cases where manufacturer's warranty and guarantee are not applicable for the items for which bids are invited. If the supply consists of number of items, indicate the specific item (s) for which alone the above authorization is required.

8. DECLARATION FOR CLAIMING TAX/DUTY EXEMPTION⁵

(Name of the Project)

Bid No.

Description of item to be supplied

.....
.....

.....

(Information for issue of certificate for claiming exemption of Tax/ Duty in terms of Government of India's relevant notification)

(Bidder's Name and Address):

**To
(Name of
Purchaser)**

.....

Dear Sir:

1. We confirm that we are solely responsible for obtaining deemed export benefits which we have considered in our bid and in case of failure to receive such benefits for reasons whatsoever, Purchaser will not compensate us.
2. We are furnishing below the information required by the Purchaser for issue of necessary certificate in terms of Government of India's relevant notification.

(i) Ex-factory price per unit on which the tax/duty is payable: *Rs.

(ii) No of Units to be supplied:

(iii) Total cost on which the tax/duty is payable (Rs.)

*(The requirements listed above are as per
Current notifications. These may be modified,
as necessary, in terms of the rules in force)*

⁵This declaration refers to ITB 14.9 and shall be retained only if ITB 14.9 is retained. The format may be modified as per the latest instructions of Government of India.

(Signature) _____
(Printed Name) _____
(Designation) _____
(Common Seal) _____

** Please attach details item-wise with cost,if there are more than one items. The figures indicated should tally with what is given in the price schedule.*

9. PERFORMA FOR PERFORMANCE STATEMENT

[Please see ITB Clause 36.2 and Section III-
Evaluation and Qualification Criteria]

Proforma for Performance Statement (for a period of last three/five years)

Bid No. _____ Date of opening _____ Time
_____ Hours

Name of the Firm _____

<u>Order placed by (full address of Purchaser)</u>	<u>Order No. and date</u>	<u>Description and quantity of ordered equipment</u>	<u>Value of order</u>	<u>Date of completion of delivery</u>		<u>Remarks indicating reasons for late delivery, if any</u>	<u>Has the equipment been satisfactorily functioning? (Attach a certificate from the Purchaser/Consignee)</u>
				As per Contract	Actual		
1	2	3	4	5	6	7	8

Signature and seal of the Bidder _____

SECTION V. – ELIGIBLE COUNTRIES

PublicInformationCenter

**Eligibility for the Provision of Goods, Works and Non Consulting Services in
Bank-Financed Procurement**

In reference to ITB 4.7 and 5.1, for the information of the Bidders, at the present time firms, goods and services from the following countries are excluded from this bidding process:

Under ITB 4.7(a) and 5.1: *None*

Under ITB 4.7(b) and 5.1: *None*

SECTION VI. BANK POLICY - CORRUPT AND FRAUDULENT PRACTICES

Guidelines for Procurement of Goods, Works, and Non-Consulting Services under IBRD Loans and IDA Credits & Grants by World Bank Borrowers, dated January 2011.

“Fraud and Corruption:

1.16 It is the Bank’s policy to require that Borrowers (including beneficiaries of Bank loans), bidders, suppliers, Contractors and their agents (whether declared or not), sub-Contractors, sub-consultants, service providers or suppliers, and any personnel thereof, observe the highest standard of ethics during the procurement and execution of Bank-financed Contracts.⁶ In pursuance of this policy, the Bank:

- (a) defines, for the purposes of this provision, the terms set forth below as follows:
 - (i) “corrupt practice” is the offering, giving, receiving, or soliciting, directly or indirectly, of anything of value to influence improperly the actions of another party;⁷
 - ii) “fraudulent practice” is any act or omission, including a misrepresentation, that knowingly or recklessly misleads, or attempts to mislead, a party to obtain a financial or other benefit or to avoid an obligation;⁸
 - (iii) “collusive practice” is an arrangement between two or more parties designed to achieve an improper purpose, including to influence improperly the actions of another party;⁹
 - (iv) “coercive practice” is impairing or harming, or threatening to impair or harm, directly or indirectly, any party or the property of the party to influence improperly the actions of a party;¹⁰
 - (v) "obstructive practice" is:

⁶ In this context, any action to influence the procurement process or contract execution for undue advantage is improper.

⁷ For the purpose of this sub-paragraph, “*another party*” refers to a public official acting in relation to the procurement process or contract execution. In this context, “*public official*” includes World Bank staff and employees of other organizations taking or reviewing procurement decisions.

⁸ For the purpose of this sub-paragraph, “party” refers to a public official; the terms “benefit” and “obligation” relate to the procurement process or contract execution; and the “act or omission” is intended to influence the procurement process or contract execution.

⁹ For the purpose of this sub-paragraph, “parties” refers to participants in the procurement process (including public officials) attempting either themselves, or through another person or entity not participating in the procurement or selection process, to simulate competition or to establish bid prices at artificial, non-competitive levels, or are privy to each other’s bid prices or other conditions.

¹⁰ For the purpose of this sub-paragraph, “party” refers to a participant in the procurement process or contract execution.

- (aa) deliberately destroying, falsifying, altering, or concealing of evidence material to the investigation or making false statements to investigators in order to materially impede a Bank investigation into allegations of a corrupt, fraudulent, coercive or collusive practice; and/or threatening, harassing or intimidating any party to prevent it from disclosing its knowledge of matters relevant to the investigation or from pursuing the investigation, or
 - (bb) acts intended to materially impede the exercise of the Bank’s inspection and audit rights provided for under paragraph 1.16(e) below.
- (b) will reject a proposal for award if it determines that the bidder recommended for award, or any of its personnel, or its agents, or its sub-consultants, sub-Contractors, service providers, suppliers and/or their employees, has, directly or indirectly, engaged in corrupt, fraudulent, collusive, coercive, or obstructive practices in competing for the Contract in question;
 - (c) will declare mis-procurement and cancel the portion of the loan allocated to a Contract if it determines at any time that representatives of the Borrower or of a recipient of any part of the proceeds of the loan engaged in corrupt, fraudulent, collusive, coercive, or obstructive practices during the procurement or the implementation of the Contract in question, without the Borrower having taken timely and appropriate action satisfactory to the Bank to address such practices when they occur, including by failing to inform the Bank in a timely manner at the time they knew of the practices;
 - (d) will sanction a firm or individual, at any time, in accordance with the prevailing Bank’s sanctions procedures,¹¹ including by publicly declaring such firm or individual ineligible, either indefinitely or for a stated period of time:
 - (i) to be awarded a Bank-financed Contract; and (ii) to be a nominated¹²;
 - (e) will require that a clause be included in bidding documents and in Contracts financed by a Bank loan, requiring bidders, suppliers and Contractors, and their sub-Contractors, agents, personnel, consultants, service providers, or suppliers, to permit the Bank to inspect all accounts, records, and other

¹¹ A firm or individual may be declared ineligible to be awarded a Bank financed contract upon: (i) completion of the Bank’s sanctions proceedings as per its sanctions procedures, including, inter alia, cross-debarment as agreed with other International Financial Institutions, including Multilateral Development Banks, and through the application the World Bank Group corporate administrative procurement sanctions procedures for fraud and corruption; and (ii) as a result of temporary suspension or early temporary suspension in connection with an ongoing sanctions proceeding. See footnote 14 and paragraph 8 of Appendix 1 of these Guidelines.

¹² A nominated sub-contractor, consultant, manufacturer or supplier, or service provider (different names are used depending on the particular bidding document) is one which has either been: (i) included by the bidder in its pre-qualification application or bid because it brings specific and critical experience and know-how that allow the bidder to meet the qualification requirements for the particular bid; or (ii) appointed by the Borrower.

documents relating to the submission of bids and Contract performance, and to have them audited by auditors appointed by the Bank.”

PART 2 - SUPPLY REQUIREMENTS

SECTION VII – SCHEDULE OF REQUIREMENTS

1. List of Goods and Delivery Schedule

Line Item No	Description of Goods	Quantity	Physical Unit	Final (Site)Destination as specified in BDS	Delivery (As per Incoterm) date		
					Earliest Delivery Date	Latest Delivery Date	Bidder's offered Delivery date
1.	(ARG) RTDAS Station of I&WDWEST BENGAL						
1a	Automated Rain Gauge (ARG) Stations Equipment set with necessary hardware as per technical specifications	41	Nos.	As per list of Installation sites for RTDAS system	4 months from date of signing of Contract	4 months from date of signing of Contract	
1b	Data Logger with 2 AI channels with INSAT, GSM & GPRS based telemetry including antenna and all necessary equipment for data transmission as per technical specifications.	41	Nos.	As per list of Installation sites for RTDAS system	4 months from date of signing of Contract	4 months from date of signing of Contract	
1c	Solar panel with all connectors, cables and conduit as per technical specifications.	41	Nos.	As per list of Installation sites for RTDAS system	4 months from date of signing of Contract	4 months from date of signing of Contract	
1d	Battery, charger regulator with all interconnecting connectors, cables for DCP as per technical specifications	41	Nos.	As per list of Installation sites for RTDAS system	4 months from date of signing of Contract	4 months from date of signing of Contract	
1e	NEMA4X OR Equivalent Enclosure box to suit master unit equipment with locking, other ancillary equipment, fittings earthing, lightening arrestor with all connectors, cables	41	Nos.	As per list of Installation sites for RTDAS system	4 months from date of signing of Contract	4 months from date of signing of Contract	

	and conduit for cables, mast to mount DCP, sensor mount complete as per technical specifications						
2.	(AWS) RTDAS Station of I&WD WEST BENGAL						
	AWS includes below equipment's						
2a	Automated Rainfall Stations (ARS) Sensor Equipment set necessary hardware as per technical specifications.	03	Nos.	As per list of Installation sites for RTDAS system	4 months from date of signing of Contract	4 months from date of signing of Contract	
2b	Air Temperature & Relative Humidity sensor, cable with Radiation shield, Equipment set necessary hardware as per technical specifications	03	Nos.	As per list of Installation sites for RTDAS system	4 months from date of signing of Contract	4 months from date of signing of Contract	
2c	Wind speed & wind direction sensor and cable set necessary hardware as per technical specifications	03	Nos.	As per list of Installation sites for RTDAS system	4 months from date of signing of Contract	4 months from date of signing of Contract	
2d	Atmospheric Pressure sensor and cable set necessary hardware as per technical specifications	03	Nos.	As per list of Installation sites for RTDAS system	4 months from date of signing of Contract	4 months from date of signing of Contract	
2e	Solar Radiation sensor and cable set necessary hardware as per technical specifications	03	Nos.	As per list of Installation sites for RTDAS system	4 months from date of signing of Contract	4 months from date of signing of Contract	

2f	Automated pan evaporimeter Equipment set necessary hardware as per technical specifications	03	Nos.	As per list of Installation sites for RTDAS system	4 months from date of signing of Contract	4 months from date of signing of Contract	
2g	Data Logger with 8 AI channels with INSAT, GSM & GPRS based telemetry including antenna and all necessary equipment for data transmission as per technical specifications.	03	Nos.	As per list of Installation sites for RTDAS system	4 months from date of signing of Contract	4 months from date of signing of Contract	
2h	Solar panel with all connectors, cables and conduit as per technical specifications	03	Nos.	As per list of Installation sites for RTDAS system	4 months from date of signing of Contract	4 months from date of signing of Contract	
2i	Battery, charger regulator with all interconnecting connectors, cables for DCP as per technical specifications	03	Nos.	As per list of Installation sites for RTDAS system	4 months from date of signing of Contract	4 months from date of signing of Contract	
2j	NEMA4X OR Equivalent Enclosure box to suit master unit equipment with locking, other ancillary equipment, fittings earthing, lightening arrestor with all connectors, cables and conduit for cables, 10mts tower with guy rope to mount DCP, sensor mount complete as per technical specifications	03	Nos.	As per list of Installation sites for RTDAS system	4 months from date of signing of Contract	4 months from date of signing of Contract	
3.	(AWLR) RTDAS Station of I&WD WEST BENGAL						
3a	Automated Water Level Recorder (non-contact RADAR) for River /Canal/Reservoir having 35m range with all necessary hardware as per technical specifications	56	Nos.	As per list of Installation sites for RTDAS system	4 months from date of signing of Contract	4 months from date of signing of Contract	

3b	Data Logger with 2 AI channels with INSAT, GSM & GPRS based telemetry including antenna and all necessary equipment for data transmission as per technical specifications.	56	Nos.	As per list of Installation sites for RTDAS system	4 months from date of signing of Contract	4 months from date of signing of Contract	
3c	Solar panel with all connectors, cables and conduit as per technical specifications	56	Nos.	As per list of Installation sites for RTDAS system	4 months from date of signing of Contract	4 months from date of signing of Contract	
3d	Battery, charger regulator with all interconnecting connectors, cables for DCP as per technical specifications	56	Nos.	As per list of Installation sites for RTDAS system	4 months from date of signing of Contract	4 months from date of signing of Contract	
3e	NEMA4X OR Equivalent Enclosure box to suit master unit equipment with locking, other ancillary equipment, fittings earthing, lightening arrestor with all connectors, cables and conduit for cables, mast to mount DCP, sensor mount complete as per technical specifications	56	Nos.	As per list of Installation sites for RTDAS system	4 months from date of signing of Contract	4 months from date of signing of Contract	
4.	(AWLR+ Gate Sensors) RTDAS Station of I&WD WEST BENGAL Hinglow Reservoir (Hinglow Dam)						
4a	Automated Water Level Recorder (non-contact RADAR) for River /Canal/Reservoir having 35m range with all necessary hardware as per technical specifications	01	Nos.	As per list of Installation sites for RTDAS system	4 months from date of signing of Contract	4 months from date of signing of Contract	
4b	Shaft Encoder based rotary position Type Gate Position Sensors for indication and monitoring of Spillway gates, Intake Gates, Silt flushing gates including cabling& conduits as per technical specifications	11	Nos.	As per list of Installation sites for RTDAS system	4 months from date of signing of Contract	4 months from date of signing of Contract	
4d	Data Logger with 8 AI channels with INSAT,	02	Nos.	As per list of	4 months from	4 months from date	

	GSM & GPRS based telemetry including antenna and all necessary equipment for data transmission as per technical specifications			Installation sites for RTDAS system	date of signing of Contract	of signing of Contract	
4e	Solar panel with all connectors, cables and conduit as per technical specifications	02	Nos.	As per list of Installation sites for RTDAS system	4 months from date of signing of Contract	4 months from date of signing of Contract	
4f	Battery, charger regulator with all interconnecting connectors, cables for DCP as per technical specifications	02	Nos.	As per list of Installation sites for RTDAS system	4 months from date of signing of Contract	4 months from date of signing of Contract	
4g	NEMA4X OR Equivalent Enclosure box to suit master unit equipment with locking, other ancillary equipment, fittings earthing, lightening arrestor with all connectors, cables and conduit for cables, mast to mount DCP, sensor mount complete as per technical specifications	02	Nos.	As per list of Installation sites for RTDAS system	4 months from date of signing of Contract	4 months from date of signing of Contract	
4h	LED Running Text Display unit to be integrated with RTDAS datalogger to display the Hydro-met Data string in running text for indoor and outdoor application with cable, fixing arrangement, accessories complete as technical per specifications	01	Nos.	As per list of Installation sites for RTDAS system	4 months from date of signing of Contract	4 months from date of signing of Contract	
5.	(AWLR+ Gate Sensors) RTDAS Station of I&WD WEST BENGAL Kangsabati Reservoir (Mukutmanipur Dam)						
5a	Automated Water Level Recorder (non-contact RADAR) for River/Canal/Reservoir having 35m range with all necessary hardware as per technical specifications	01	Nos.	As per list of Installation sites for RTDAS system	4 months from date of signing of Contract	4 months from date of signing of Contract	
5b	Shaft Encoder based rotary position Type	16	Nos.	As per list of	4 months from	4 months from date	

	Gate Position Sensors for indication and monitoring of Spillway gates/Intake Gates/Silt flushing gates including cabling & integration with datalogger as per technical specifications.			Installation sites for RTDAS system	date of signing of Contract	of signing of Contract	
5c	Data Logger with 2 AI channels with INSAT, GSM & GPRS based telemetry including antenna and all necessary equipment for data transmission as per technical specifications.	01	Nos.	As per list of Installation sites for RTDAS system	4 months from date of signing of Contract	4 months from date of signing of Contract	
5d	Data Logger with 8 AI channels with INSAT, GSM & GPRS based telemetry including antenna and all necessary equipment for data transmission as per technical specifications.	02	Nos.	As per list of Installation sites for RTDAS system	4 months from date of signing of Contract	4 months from date of signing of Contract	
5e	Solar panel with all connectors, cables and conduit as per technical specifications	03	Nos.	As per list of Installation sites for RTDAS system	4 months from date of signing of Contract	4 months from date of signing of Contract	
5f	Battery, charger regulator with all interconnecting connectors, cables for DCP as per technical specifications	03	Nos.	As per list of Installation sites for RTDAS system	4 months from date of signing of Contract	4 months from date of signing of Contract	
5g	NEMA4X OR Equivalent Enclosure box to suit master unit equipment with locking, other ancillary equipment, fittings earthing, lightning arrester with all connectors, cables and conduit for cables, mast to mount DCP, sensor mount complete as per technical specifications	03	Nos.	As per list of Installation sites for RTDAS system	4 months from date of signing of Contract	4 months from date of signing of Contract	
5h	LED Running Text Display unit to be integrated with RTDAS datalogger to display	01	Nos.	As per list of Installation sites for	4 months from date of signing of	4 months from date of signing of	

	the Hydro-met Data string in running text for indoor and outdoor application with cable, fixing arrangement, accessories complete as technical per specifications			RTDAS system	Contract	Contract	
6	Set of Data Center Equipment to collect and store the data received from proposed DCPs established across the state of West Bengal to the central data center located at Bidhannagar, Kolkata						
6a	Server along with server rack, Monitor and 3 KVA online UPS as per technical specifications	01	Set	As per list of Installation sites for RTDAS system	4 months from date of signing of Contract	4 months from date of signing of Contract	
6b	Computer Node (Workstation) along with Monitor and necessary accessories as per technical specifications	01	Set	As per list of Installation sites for RTDAS system	4 months from date of signing of Contract	4 months from date of signing of Contract	
6c	IT Hardware which includes required Static IP, Router, Switch, firewall system and A3 colour printer as per technical specifications and necessary accessories.	01	Set	As per list of Installation sites for RTDAS system	4 months from date of signing of Contract	4 months from date of signing of Contract	
6d	55" LED Display System as per technical specifications	01	No.	As per list of Installation sites for RTDAS system	4 months from date of signing of Contract	4 months from date of signing of Contract	
6e	High speed synchronous internet connection (min. 8 mbps upload and 8 mbps download) for five years.	01	No.	As per list of Installation sites for RTDAS system	4 months from date of signing of Contract	4 months from date of signing of Contract	
6f	GSM & GPRS data receiving system with all ancillary equipment, as per technical specifications.	01	No.	As per list of Installation sites for RTDAS system	4 months from date of signing of Contract	4 months from date of signing of Contract	

2.LIST OF RELATED SERVICES {[ITB CLAUSE 14.8B]} AND COMPLETION SCHEDULE

Service No	Description of Services (excludes inland transportation and other services required in India to convey the goods to their final destination)	Quantity	Physical Unit	Place where Services shall be performed	Final Completion Date of Services
1	2	3	4	5	6
	Installation of the systems including civil works which also include Performance and supervision of the on-site assembly and/or start-up of the supplied Goods				
S-1	(ARG) RTDAS Station of I&WD WEST BENGAL				
S-1a	Installation testing & Commissioning of Automated Rain Gauge (ARG) Stations Equipment set with necessary hardware including associated civil works as per technical specifications.	41	Nos.	West Bengal as per table in Schedule of Requirement.	09 months from date of signing of Contract
S-1b	Installation testing & Commissioning of Data Logger with 2 AI channels with INSAT, GSM & GPRS based telemetry including antenna and all necessary equipment for data transmission as per technical specifications.	41	Nos.	West Bengal as per table in Schedule of Requirement.	09 months from date of signing of Contract
S-1c	Installation testing & Commissioning of solar panel with all connectors, cables and conduit as per technical specifications	41	Nos.	West Bengal as per table in Schedule of Requirement.	09 months from date of signing of Contract
S-1d	Installation, Testing & Commissioning of Battery, charger regulator with all interconnecting connectors, cables for DCP as per technical specifications	41	Nos.	West Bengal as per table in Schedule of Requirement.	09 months from date of signing of Contract
S-1e	Installation, Testing & Commissioning of NEMA4X or equivalent Enclosure box to suit master unit equipment with locking, other	41	Nos.	West Bengal as per table in Schedule of Requirement.	09 months from date of signing of Contract

	ancillary equipment, fittings earthing, lightening arrestor with all connectors, cables and conduit for cables, mast to mount DCP, sensor mount complete as per technical specifications				
S-1f	Installation of Chain link Fencing (5m*5m) *2m including associated civil works for independent ARG sensors (line item no. S-1) only, along with lockable gates for external protection of ARG and DCP at remote stations as mentioned in Schedule of Requirements	41	Nos.	West Bengal as per table in Schedule of Requirement.	09 months from date of signing of Contract
S-2	(AWS) RTDAS Station of I&WD WEST BENGAL				
	AWS includes below Equipment's				
S-2a	Installation testing & Commissioning of Automated Rainfall Stations (ARS) Sensor Equipment set necessary hardware as per technical specifications.	03	Nos.	West Bengal as per table in Schedule of Requirement.	09 months from date of signing of Contract
S-2b	Installation testing & Commissioning of Air Temperature & Relative Humidity sensor, cable with Radiation shield, Equipment set necessary hardware as per technical specifications	03	Nos.	West Bengal as per table in Schedule of Requirement.	09 months from date of signing of Contract
S-2c	Installation testing & Commissioning of Wind speed & wind direction sensor and cable set necessary hardware as per technical specifications	03	Nos.	West Bengal as per table in Schedule of Requirement.	09 months from date of signing of Contract
S-2d	Installation testing & Commissioning of Atmospheric Pressure sensor and cable set necessary hardware as per technical specifications	03	Nos.	West Bengal as per table in Schedule of Requirement.	09 months from date of signing of Contract

S-2e	Installation testing & Commissioning of Solar Radiation sensor and cable set necessary hardware as per technical specifications	03	Nos.	West Bengal as per table in Schedule of Requirement.	09 months from date of signing of Contract
S-2f	Installation testing & Commissioning of Automated pan evaporimeter Equipment set necessary hardware as per technical specifications	03	Nos.	West Bengal as per table in Schedule of Requirement.	09 months from date of signing of Contract
S-2g	Installation testing & Commissioning of Data Logger with 8 AI channels with INSAT, GSM & GPRS based telemetry including antenna and all necessary equipment for data transmission as per technical specifications.	03	Nos.	West Bengal as per table in Schedule of Requirement.	09 months from date of signing of Contract
S-2 h	Installation testing & Commissioning of solar panel with all connectors, cables and conduit as per technical specifications	03	Nos.	West Bengal as per table in Schedule of Requirement.	09 months from date of signing of Contract
S-2 i	Installation, Testing & Commissioning of Battery, charger regulator with all interconnecting connectors, cables for DCP as per technical specifications	03	Nos.	West Bengal as per table in Schedule of Requirement.	09 months from date of signing of Contract
S-2 j	Installation, Testing & Commissioning of NEMA4X or equivalent Enclosure box to suit master unit equipment with locking, other ancillary equipment, fittings earthing, lightning	03	Nos.	West Bengal as per table in Schedule of Requirement.	09 months from date of signing of Contract

	arrester with all connectors, cables and conduit for cables, 10mts tower with guy ropeto mount DCP, sensor mount complete as per technical specifications.				
S-2 k	Installation of Chain Link Fencing (10m*10m)*2m including associated civil works for independent AWS stations (line item no. S-2) only, along with lockable gates for external protection of AWS and DCP at remote stations as mentioned in Schedule of Requirements.	03	Nos.	West Bengal as per table in Schedule of Requirement.	09 months from date of signing of Contract
S-3	(AWLR) RTDAS Station of I&WD WEST BENGAL				
S-3a	Installationtesting & Commissioning of Automated Water Level Recorder (non-contact RADAR) for River /Canal/Reservoir having 35m range with all necessary hardware including associated civil works & mounting arrangements as per technical specifications.	56	Nos.	West Bengal as per table in Schedule of Requirement.	09 months from date of signing of Contract
S-3b	Installation testing & Commissioning of Data Logger with 2 AI channels with INSAT, GSM & GPRS based telemetry including antenna and all necessary equipment for data transmission as per technical specifications.	56	Nos.	West Bengal as per table in Schedule of Requirement.	09 months from date of signing of Contract
S-3 c	Installation testing & Commissioning of solar panel, charger regulator, batteries, earthing&lightening arrester with all connectors, NEMA4X box to suit master unit with locking, cables and conduit for cables, mast/tower& associated Civil works to mount DCP as per technical specifications	56	Nos.	West Bengal as per table in Schedule of Requirement.	09 months from date of signing of Contract

S-3 d	Installation, Testing & Commissioning of Battery, charger regulator with all interconnecting connectors, cables for DCP as per technical specifications	56	Nos.	West Bengal as per table in Schedule of Requirement.	09 months from date of signing of Contract
S-3 e	Installation, Testing & Commissioning of NEMA4X or equivalent Enclosure box to suit master unit equipment with locking, other ancillary equipment, fittings earthing, lightning arrestor with all connectors, cables and conduit for cables, mast to mount DCP, sensor mount complete as per technical specifications	56	Nos.	West Bengal as per table in Schedule of Requirement.	09 months from date of signing of Contract
S-4	(AWLR+ Gate Sensors) RTDAS Station of I&WD WEST BENGAL Hinglow Reservoir (Hinglow Dam)				
S-4a	Installation testing & Commissioning of Automated Water Level Recorder (non-contact RADAR) for River /Canal/Reservoir having 35m range with all necessary hardware including associated civil works& mounting arrangements as per technical specifications.	01	No.	West Bengal as per table in Schedule of Requirement.	09 months from date of signing of Contract
S-4b	Installation testing & Commissioning of Shaft Encoder based rotary position type, Gate Position Sensors for indication and monitoring of Spillway gates, Intake Gates, Silt flushing gates including cabling as per technical specifications.	11	Nos.	West Bengal as per table in Schedule of Requirement.	09 months from date of signing of Contract
S-4d	Installation testing & Commissioning of Data Logger 8 AI channels with INSAT, GSM & GPRS based telemetry including antenna and all necessary equipment for data transmission as per technical specifications.	02	Nos.	West Bengal as per table in Schedule of Requirement.	09 months from date of signing of Contract

S-4e	Installation testing & Commissioning of solar panel, charger regulator, batteries, earthing&lightening arrestor with all connectors, NEMA4X box to suit master unit with locking, cables and conduit for cables, mast & associated Civil works to mount DCP as per technical specifications.	02	Nos.	West Bengal as per table in Schedule of Requirement.	09 months from date of signing of Contract
S-4f	Installation, Testing & Commissioning of Battery, charger regulator with all interconnecting connectors, cables for DCP as per technical specifications	02	Nos.	West Bengal as per table in Schedule of Requirement.	09 months from date of signing of Contract
S-4g	Installation, Testing & Commissioning of NEMA4X or equivalent Enclosure box to suit master unit equipment with locking, other ancillary equipment, fittings earthing, lightening arrestor with all connectors, cables and conduit for cables, mast to mount DCP, mount complete as per technical specifications	02	Nos.	West Bengal as per table in Schedule of Requirement.	09 months from date of signing of Contract
S-4h	Installation, Testing & Commissioning of LED Running Text Display unit to be integrated with RTDAS datalogger to display the Hydro-met Data string in running text for indoor and outdoor application with cable, fixing arrangement, accessories complete as technical per specifications	01	Nos.	West Bengal as per table in Schedule of Requirement.	09 months from date of signing of Contract
S-5	(AWLR+ Gate Sensors) RTDAS Station of I&WD WEST BENGAL Kangsabati Reservoir (Mukutmanipur Dam)				
S-5a	Installation testing & Commissioning of Automated Water Level Recorder (non-contact RADAR) for River /Canal/Reservoir having 35m range with all necessary hardware including	01	No.	West Bengal as per table in Schedule of Requirement.	09 months from date of signing of Contract

	associated civil works& mounting arrangements as per technical specifications.				
S-5b	Installation testing & Commissioning of Shaft Encoder based rotary position type, Gate Position Sensors for indication and monitoring of Spillway gates, Intake Gates, Silt flushing gates including cabling as per technical specifications.	16	Nos.	West Bengal as per table in Schedule of Requirement.	09 months from date of signing of Contract
S-5c	Installation testing & Commissioning of Data Logger with 2 AI channels with INSAT, GSM & GPRS based telemetry including antenna and all necessary equipment for data transmission as per technical specifications.	01	No.	West Bengal as per table in Schedule of Requirement.	09 months from date of signing of Contract
S-5d	Installation testing & Commissioning of Data Logger 8 AI channels with INSAT, GSM & GPRS based telemetry including antenna and all necessary equipment for data transmission as per technical specifications.	02	Nos.	West Bengal as per table in Schedule of Requirement.	09 months from date of signing of Contract
S-5e	Installation testing & Commissioning of solar panel with all connectors, cables and conduit as per technical specifications.	03	Nos.	West Bengal as per table in Schedule of Requirement.	09 months from date of signing of Contract
S-5f	Installation, Testing & Commissioning of Battery, charger regulator with all interconnecting connectors, cables for DCP as per technical specifications	03	Nos.	West Bengal as per table in Schedule of Requirement.	09 months from date of signing of Contract
S-5g	Installation, Testing & Commissioning of NEMA4X or equivalent Enclosure box to suit master unit equipment with locking, other ancillary equipment, fittings earthing, lightning arrester with all connectors, cables and conduit for cables, mast to mount DCP, sensor mount	03	Nos.	West Bengal as per table in Schedule of Requirement.	09 months from date of signing of Contract

	complete as per technical specifications				
S-5h	Installation, Testing & Commissioning of LED Running Text Display unit to be integrated with RTDAS datalogger to display the Hydro-met Data string in running text for indoor and outdoor application with cable, fixing arrangement, accessories complete as technical per specifications	01	Nos.	West Bengal as per table in Schedule of Requirement.	09 months from date of signing of Contract
S-6	Set of Data Center Equipment to collect and store the data received from proposed DCPs established across the state of West Bengal to the central data center located at Bidhannagar, Kolkata				
S-6a	Installation testing & Commissioning of Server along with server rack, Monitor and 3 KVA online UPS as per technical specifications	01	No.	West Bengal as per table in Schedule of Requirement.	6 months from date of signing of Contract
S-6b	Installation, Testing & Commissioning of Computer Node (Workstation) along with Monitor and necessary accessories as per technical specifications	01	No.	West Bengal as per table in Schedule of Requirement.	6 months from date of signing of Contract
S-6c	Installation testing & Commissioning of IT Hardware which includes required Static IP, Router, Switch, firewall system and A3 Size colour printer and necessary accessories as per technical specifications	01	No.	West Bengal as per table in Schedule of Requirement.	6 months from date of signing of Contract
S-6d	Installation testing & Commissioning of 55" LED Display System as per technical specifications	01	No.	West Bengal as per table in Schedule of Requirement.	6 months from date of signing of Contract
S-6e	Installation testing & Commissioning for high speed synchronous internet connection (min. 8	01	No.	West Bengal as per table in Schedule of Requirement.	6 months from date of signing of Contract

	mbps upload and 8 mbps download) for Five years				
S-6f	Installation testing & Commissioning of GSM & GPRS data receiving system with all ancillary equipments as per technical specifications	01	No.	West Bengal as per table in Schedule of Requirement.	6 months from date of signing of Contract
S-7	Operation & Maintenance and Comprehensive Warranty for RTDAS with Telemetry system as specified in Schedule of Requirement along with accessories, installed at designated locations within West Bengal and Data Center equipments after final acceptance of RTDAS systems. This includes replacement of material / goods & consumable as & when required at bidders cost. The cost of Communication for GSM & GPRS telemetry for data transmission shall be borne by bidder. The license fee as applicable for DOT for INSAT transmission shall be borne by purchaser. This also includes availability of minimum One Service Engineer shall be placed at State Data Center for Operation and Maintenance of RTDAS system with Telemetry for entire warranty period of 5 years.	01	Lot	West Bengal as per table in Schedule of Requirement.	5 years after successful commissioning and final acceptance certificate of RTDAS
S-8	Training of the purchaser's personnel at the supplier's plant and/or/onsite in assembly, startup, operation, maintenance and/or repair of the supplied goods. Course topics will include sensor calibration, data logger configuration, data downloading, data retrieval, collection, Trouble shooting, processing maintenance requirements and procedure for equipment configuration, installation, site testing and commissioning including training kit containing course material	08	Year	West Bengal as per table in Schedule of Requirement.	During O & M and warranty period of 5 years

	in soft and hard copies as per technical specification				
--	--	--	--	--	--

Details of Hydro-meteorological Equipment to be installed							
RIVER GAUGES							
Sl. No.	Name of the Site	River/ Tributary	District / Taluka	Lattitude (N)	Longitude (E)	Type of site	Sensor Type
1	Alipurduar	Kaljani	Alipurduar	26.480157	89.515881	Road Bridge	Radar
2	NH-31D Crossing	Mujnai	Alipurduar	26.519988	89.170432	Road Bridge	Radar
3	Coochbehar	Torsa	Coochbehar	26.251310	89.611339	Road Bridge	Radar
4	Dharla Aqueduct	Dharla	Jalpaiguri	26.691721	88.736939	Hydraulic Structure	Radar
5	Hill Curt Road	Mahananda	Darjeeling	26.719813	88.419856	Road Bridge	Radar
6	Raiganj	Kulik	Uttar Dinajpur	25.636022	88.122259	Road Bridge	Radar
7	Makdampur	Nagar	Uttar Dinajpur	25.708746	88.046213	Road Bridge	Radar
8	Balurghat	Atreyee	DakshinDinajpur	25.228237	88.772224	Road Bridge	Radar
9	Gangarampur	Punarbhaba	DakshinDinajpur	25.405787	88.513281	Road Bridge	Radar
10	Bansihari	Tangon	DakshinDinajpur	25.395970	88.416595	Road Bridge	Radar
11	Englishbazar	Mahananda	Malda	25.014936	88.144409	Road Bridge	Radar
12	Bankura	Dwarakeswar	Bankura	23.212857	87.076035	Road Bridge	Radar
13	Bankura	Gandheswari	Bankura	23.237074	87.084168	Road Bridge	Radar
14	Illambazar	Ajay	Birbhum	23.615138	87.531678	Road Bridge	Radar
15	Bansloi Road Bridge	Bansloi	Birbhum	24.479712	87.861192	Road Bridge	Radar
16	Paikar	Pagla	Birbhum	24.436354	87.898999	Road Bridge	Radar
17	Katwa	Ajay	PurbaBurdwan	23.654644	88.134791	Road Bridge	Radar
18	Burdwan	Damodar	PurbaBurdwan	23.211614	87.848477	Road Bridge	Radar
19	Randiha Weir	Damodar	PaschimBurdwan	23.372641	87.475325	Hydraulic Structure	Radar
20	Guskara	Kunur	PurbaBurdwan	23.285303	88.141147	Road Bridge	Radar
21	Champadanga	Damodar	Hooghly	22.840060	87.969621	Road Bridge	Radar

22	Arambag	Dwarakeswar	Hooghly	22.887077	87.775808	Road Bridge	Radar
23	Muchighata	Hurhura	Hooghly	22.635565	87.899648	Road Bridge	Radar
24	Amta	Amta Channel	Howrah	22.573748	87.998360	Road Bridge	Radar
25	Bakshi	Short Cut Channel	Howrah	22.531268	87.897570	Road Bridge	Radar
26	Bazarshow	Babla	Murshidabad	23.839582	88.161487	River Bank	Radar
27	Berhampore	Bhagirathi	Murshidabad	24.100421	88.244311	Road Bridge	Radar
28	Sankoghat	Dwarka	Murshidabad	24.156346	88.017066	Road Bridge	Radar
29	Ranagram	Dwarka	Murshidabad	24.016806	88.093360	Road Bridge	Radar
30	Tarapur	Kuia	Murshidabad	23.839406	87.968376	Road Bridge	Radar
31	Hanskhali	Churni	Nadia	23.355547	88.607073	Road Bridge	Radar
32	Swarupganj	Hooghly	Nadia	23.385263	88.367727	River Bank	Radar
33	Krishnanagar	Jalangi	Nadia	23.413683	88.471300	Road Bridge	Radar
34	Ghusighata	Bidyadhari	North 24 Parganas	22.524207	88.687412	Road Bridge	Radar
35	Gaighata	Jamuna	North 24 Parganas	22.931127	88.732460	Road Bridge	Radar
36	Tentulia	Ichamati	North 24 Parganas	22.787288	88.852451	Road Bridge	Radar
37	Barisha	Chandia	PaschimMedinipur	22.245505	87.703644	Road Bridge	Radar
38	Khukurdah	Durbachati	PaschimMedinipur	22.473935	87.750782	Road Bridge	Radar
39	Dehati	Kaliaghai	PaschimMedinipur	22.090965	87.495089	Road Bridge	Radar
40	Sal Dahari	Kangsabati	PaschimMedinipur	22.488876	87.558162	River Bank	Radar
41	Khirpai	Ketia	PaschimMedinipur	22.720523	87.602071	Road Bridge	Radar
42	Kapastikri	Old Cossye	PaschimMedinipur	22.498421	87.558884	River Bank	Radar
43	Tabageria	New Cossye	PaschimMedinipur	22.484145	87.579123	River Bank	Radar
44	Goura	Palashpai	PaschimMedinipur	22.545484	87.854500	Road Bridge	Radar
45	Bandar	Rupnarayan	PaschimMedinipur	22.661713	87.731618	River Bank	Radar
46	Banka	Shilabati	PaschimMedinipur	22.727636	87.577081	Road Bridge	Radar
47	Garhbeta	Shilabati	PaschimMedinipur	22.886163	87.361286	Road Bridge	Radar
48	Ghatal	Shilabati	PaschimMedinipur	22.661713	87.731618	Road Bridge	Radar

49	Narghat	Haldi	PurbaMedinipur	22.135447	87.890932	Road Bridge	Radar
50	Moyna	New Cossye	PurbaMedinipur	22.248224	87.798520	Road Bridge	Radar
51	Panskura	New Cossye	PurbaMedinipur	22.395875	87.712793	Road Bridge	Radar
52	Kalinagar	Rasulpur	PurbaMedinipur	21.916866	87.786026	Road Bridge	Radar
53	Petuaghat	Rasulpur	PurbaMedinipur	21.795455	87.881636	River Bank	Radar
54	Budhpur	Cossye	Purulia	22.531268	87.897570	Road Bridge	Radar
55	Dabra	Kumari	Purulia	22.573748	87.998360	Road Bridge	Radar
56	Diamond harbour	Hooghly	South 24-Pargans	22.193544	88.181347	River Bank	Radar

Details of Hydro-meteorological Equipment to be installed
RAIN GAUGES & AWS

Sl. No.	Name of the Site	River / Tributary	District / Taluka	Latitude (N)	Longitude (E)	Sensor Type	Remarks
1	Banarhat	Jaldhaka	Jalpaiguri	26.794000	89.02525	ARG	
2	Dalkhola	Mahananda	North Dinajpur	25.876231	87.844303	ARG	New Site
3	Karnajora	Kulik	North Dinajpur	25.653618	88.154161	ARG	New Site
4	Balurghat	Atreyee	South Dinajpur	25.518834	88.09345	ARG	
5	Bishnupur	Dwarakeswar	Bankura	23.080000	87.320000	ARG	New Site
6	Indus	Dwarakeswar	Bankura	23.150587	87.621309	ARG	
7	Kenduadihi	Dwarakeswar	Bankura	23.230267	87.050337	ARG	
8	Taldangra	Shilabati	Bankura	22.999655	87.099753	ARG	
9	Shyambati	Kopai	Birbhum	23.694512	87.681606	ARG	
10	Paikar	Pagla	Birbhum	24.432831	87.910331	ARG	
11	Satkahania	Ajay	PaschimBurdwan	23.596498	87.500395	ARG	
12	Memari	Behula	PurbaBurdwan	23.173334	88.095281	ARG	
13	Galsi	Damodar	PurbaBurdwan	23.344731	87.682500	AWS	
14	Manteswar	Khari	PurbaBurdwan	23.306178	88.136978	ARG	New Site
15	Gushkara	Kunur	PurbaBurdwan	23.482142	87.720728	ARG	
16	Raina	Mundeswari	PurbaBurdwan	23.002687	87.858034	ARG	
17	Champadanga	Damodar	Hooghly	22.836581	87.970381	ARG	
18	Arambag	Dwarakeswar	Hooghly	22.889978	87.779453	ARG	
19	Singur	Ghea	Hooghly	22.820612	88.224939	ARG	
20	Amta	Amta Channel	Howrah	22.572492	88.001253	ARG	
21	Domjur	Saraswati	Howrah	22.649848	88.191212	ARG	

22	Salar	Babla	Murshidabad	23.771800	88.183231	ARG	
23	Kandi	Mayurakshi	Murshidabad	23.951253	88.041917	ARG	
24	Swarupganj	Bhagirathi	Nadia	23.415383	88.390032	ARG	
25	Majdiha	Bhagirathi	Nadia	23.404031	88.712432	ARG	
26	Salt Lake	Bidyadhari	North 24 Parganas	22.590617	88.417589	AWS	New Site
27	Tentulia	Ichamati	North 24 Parganas	22.789750	88.854534	ARG	
28	Hijli	Kaliaghai	PaschimMedinipur	22.302765	87.303007	ARG	New Site
29	Sabang	Kaliaghai	PaschimMedinipur	22.173553	87.599134	ARG	
30	Ghatal	Rupnarayan	PaschimMedinipur	22.664131	87.738594	ARG	
31	Amlagora	Shilabati	PaschimMedinipur	22.847276	87.33489	ARG	
32	Chandrakona	Shilabati	PaschimMedinipur	22.732016	87.516456	ARG	New Site
33	Pirorgari	Shilabati	PaschimMedinipur	22.856260	87.001822	ARG	New Site
34	Salboni	Shilabati	PaschimMedinipur	22.642119	87.318483	ARG	New Site
35	Kesiapata	Subarnarekha	PaschimMedinipur	22.208892	87.133575	ARG	
36	Itamogra	Haldi	PurbaMedinipur	22.113286	87.945075	ARG	
37	Panskura	Kangsabati	PurbaMedinipur	22.395875	87.712793	ARG	
38	Egra	Pichabani	PurbaMedinipur	21.900021	87.537202	ARG	New Site
39	Itaberia	Rasulpur	PurbaMedinipur	21.998417	87.670433	ARG	New Site
40	Ramchandrapur	Damodar	Purulia	23.586845	86.826762	ARG	New Site
41	Kashipur	Dwarakeswar	Purulia	23.434136	86.667866	ARG	New Site
42	Kenda	Kangsabati	Purulia	23.195514	86.515855	ARG	New Site
43	Tatko	Kangsabati	Purulia	22.929089	86.512748	AWS	New Site
46	Uttarbhag	Sundarban	South 24 Parganas	22.343076	88.514740	ARG	

Proposed Automated Reservoir Monitoring Sites (AWLR, AWS)						
Sl. No.	Name of the Reservoir	River / Tributary	Location	District	Latitude (N)	Longitude (E)
1	Hinglow	Hinglow	Hinglow	Birbhum, West Bengal	23.822585	87.193983
2	Kangsabati	Kangsabati	Mukutmanipur	Bankura, West Bengal	22.965221	86.786532

3. TECHNICAL SPECIFICATIONS

Introduction

Irrigation and Waterways Department (IWD), Govt. of West Bengal is entrusted with the surface water resources planning, development and management. A large number of major, medium and minor water resources development projects (reservoirs, barrages and weirs) have been constructed within West Bengal. However, although the reservoirs of Damodar Valley Project are situated within the neighboring State of Jharkhand, but their operations are mainly intended for flood and irrigation management in West Bengal. The other reservoirs like Kangsabati and Hinglow, are mainly envisaged to resolve the issues like irrigation and domestic uses and are operated with rigid schedules as single entities based on the historical hydro-meteorological Data and experience gained. These methods are often not adequate for establishing optimal operational decisions, especially where integrated operation of multiple reservoirs for flood management is contemplated. In addition, manual Data observation and transmission results in a considerable time lag, between Data observed in field and its communication to decision making level which sometime leaves little time, for proper flood and irrigation management.

The Ministry of Water Resources (MoWR), Government of India (GoI) has initiated 'National Hydrology Project (NHP)' (www.indiawrm.org) in which 'Real Time Data Acquisition System (RTDAS)' has been planned for different River basins of West Bengal as one step forward for development of 'Hydrological Information System (HIS)' for surface water resources in the State. The RTDAS includes installation of Automated Rainfall Stations with INSAT, GSM /GPRS Telemetry, Automated River Gauge Stations with INSAT, GSM /GPRS Telemetry, Automated Reservoir Monitoring Systems with INSAT, GPRS/GSM Telemetry for major Dams alongwith establishment of State Data Center have also been included in NHP for the purpose of proper Flood and Irrigation management within the State.

The key objectives of the RTDAS consist of the following:

1. Install new equipment capable of providing measurements in real time at proposed RTDAS stations.
2. Provide the number of rainfall, River water level (stage) and River discharge, reservoir water level and outflow discharge and weather stations to provide improved assessments of hydrologic conditions in different River basins in West Bengal.
3. Utilize a combination of INSAT, GSM & GPRS Data communications to relay Data in real time.
4. Contract for station installation and maintenance to assure the proper operation of RTDAS.
5. Contract for extensive training for I&WD staff to fully understand the operation of the equipment in the event of operation and maintenance of RTDAS.
6. Establish real time Data Center.

1. General Technical Concept

The concept of implementation on which the present technical specifications and special conditions are based intends to acquire the state of art technology available for setting up automated Data Collection Platform (DCP), Data storage, processing and Data communication technologies with the requirements of high availability and sustainability required by such an important project. Emphasis is provided on a robust and reliable technology. The Data acquisition system will comprise of two segments, the Data acquisition segment and the Data communication segment. Data acquisition segment and Data communication segment co-operate automatically in an integrated manner to complete the cyclic function of Data collection. The Data acquisition segment comprises of sensor, Data acquisition controller/ Data logger and an integrated power controller. The Data communication segment comprises of the Data communication equipment at site, all intermediate components and the network controller / web server at Data Processing Center.

It is preferred that the rechargeable battery used at site gets uninterruptedly recharged by a solar panel attached to the system. Under the project, Data transmission has been proposed using **INSAT, GSM & GPRS** technology. Accordingly, the sites have been chosen verifying the coverage of Telecom network. This methodology has been chosen keeping in view its advantages over the other systems in respect of investment, maintenance and reliability. The Bidder shall ensure that the system remains operational even under extreme conditions of weather. The failure of transmission due to temporary disturbances in the network must be taken care of by providing adequate storage in the Data logger and ensuring subsequent relay immediately after the network is restored. Two-ways communication facility and event notification through SMS is highly desirable in the system to be provided by the Bidder. Uninterrupted Data recording must be guaranteed for long periods during which regular maintenance visits may not be possible.

Maintenance is an integral part of any system and a system that has the challenges of unattended operation in remote, exposed areas stresses the need for a well thought out approach to maintenance. The corrective maintenance will be required for Data collection issues, whether they may be component failures or due to environmental issues.

To minimize corrective maintenance and to increase the performance of the monitoring network, a well-organized preventative maintenance plan is highly recommended. The preventative maintenance is required for all system components as well as the infrastructure in place to house the electronic Data collection components. It is recognized that the maintenance of a monitoring network is often grossly underestimated as well as underperformed task. This leads to reduced life expectancy of the equipment and possibly the collection of misleading Data during the period of operation. A strong maintenance plan will be the foundation for sustaining Purchaser's monitoring network operation over the expected lifetime of the technology, which is considered to be 10 years.

The State of West Bengal has proposed the Data communication will be GSM /GPRS and INSAT, which is based on the crucial nature of the Data and/or availability of INSAT.

The Technical Specifications consist of the installation of the RTDAS for the different River basins in West Bengal. This shall include the design, manufacture, factory testing, deliver to site, installation (including the associated interface wiring/termination), commissioning and site acceptance testing, supply of mandatory spares, training and documentation.

Data Collection Platforms (DCP), monitoring system hardware and shall interface and be fully integrated and tested with the Earth Receiving Station. The requirements are given below in respect of each major component of the system. The Bidder shall ensure that the fundamental requirements stated in this document are not compromised. Further details are also provided in Inspections and Tests.

The RTDAS should have the following monitoring systems for the Hydro-met network

- ARG with INSAT, GSM & GPRS Telemetry: 41 Nos.
- AWS with INSAT, GSM & GPRSTelemetry:03Nos.
- AWLR- Radar Sensors with INSAT, GSM & GPRS Telemetry: 58 Nos. (Total AWLR is 56 nos +2 nos for Automated Reservoir Monitoring)
-
- Gate sensor: 27nos.Data Centre equipment's establishment: 01 Nos.

GENERAL

Real Time Hydro-Met data acquisition network which will be implemented under this project provides key data required for forecasting Inflows into the Basin and other related activities. A Real Time Data Acquisition System (**RTDAS**) will consist of a telemetry network of Automatic rainfall stations, automated weather station and water levels along rivers/reservoirs which will be installed to provide inputs to the **RTDAS**. The concept of implementation on which the present technical specifications and special conditions are based intends to combine the advantages of modern Data Loggers, data storage, processing and data communication technologies with the requirements of high availability and sustainability required by such an important project. Preference will be given to robust, reliable technology. The real-time data acquisition system networks have the greatest possible reliability, thus minimizing the maintenance to the extent possible.

The sensors like Automatic Rain Gauge (ARG) sensor, Automatic Weather Station (AWS), Pan evaporimeter, Automatic Water Level Recorder (AWLR), Gate Sensors should be combined within a single station which will eliminate the costs of **INSAT, GPRS & GSM** communication and the recurring costs associated with these devices. This specifically means that it is encouraged to combine data from multiple instruments through the use of wired or wireless technology to minimize the number of **INSAT, GSM & GPRS** data transmission systems.

The Technical Specifications consists of the installation of the real time data acquisition system for the.(Ganga, Brahamaputra and Subarnarekha) River basins includes the design, manufacture, factory testing, deliver to site, installation (including the associated interface wiring/termination), knowledge transfers and other accessories, commissioning and site acceptance testing, supply of mandatory spares, training and documentation.

2.0 DESIGN PRINCIPLES

The following basic principles have been applied to the design of the real time hydrological data acquisition system network for the(Ganga, Brahamaputra and Subarnarekha) **River basin**

- Installation of Water Level Recording Sensors which will have the primary function of measuring water levels at the installed locations Rivers (GD Stations / Reservoirs)
- Installation of gate sensors for measuring the gate position of reservoir gates, Reservoir data collection station/ network shall transmit this data as telemetered data in real time along with other AWLR sensors data.
- Installation of AWS with Hydro-meteorological Sensors which will have the primary function of measuring metrological data at the installed locations. Weather stations will be fully automated and transmit data in real time.
- Installation of Automatic Rain Gauge (ARG) Station with Tipping Bucket rain gauge (TBRG) Sensors which will have the primary function of measuring Rain fall data at the installed locations
- Recoded data at field stations will be transmitted through INSAT to Earth Receiving Stations (ERS) at New Delhi/Jaipur/Burla and from ERS to E-SWIS software for further processing. Simultaneously GSM/GPRS data from field stations will be communicated to the dedicated server computer provided at State Data Center (SDC) at Bidhannagar, Kolkata, and then from SDC to e-SWIS software at Delhi via internet for further processing. The processed data shall be transferred to the State Data Centre, at Bidhannagar, Kolkata via internet & e-SWIS cloud.
- Stations or sensors in close proximity to each other will be combined to reduce the number of reporting stations. This is especially important to save the recurring **INSAT, GSM & GPRS** charges.

3.0 SCOPE OF WORK

- 1) Complete supply, installation, testing, commissioning of remote stations including associated civil works, sensors, data logger, software, hardware and ancillaries' equipment, solar panel, mounting poles, masts, towers, cables, electrical and network cabling, lightning arrestors, earthing etc. complete.
- 2) Technical design, supply, installation, testing, commissioning of the real time hydrological data collection network and establish data communications using **INSAT** telemetry between the remote stations and the Earth Receiving Station at

New Delhi/Jaipur/Burla and GSM/GPRS between remote station to the dedicated computer server provided at Data Center Bidhannagar, Kolkata or at E-SWIS server. This includes, but is not limited to acquiring service, and maintaining all aspects of the service during the warranty period as well as the maintenance period.

- 3) Establish a GSM & GPRS receiving system along with all required data resection arrangement at State DataCenters, Kolkata to collect GSM & GPRS data. This shall include a required hardware & computer that will support the reception of the GSM & GPRS Data stream. This consists of acquiring all hardware and software, installation, configuration.
- 4) Providing server with monitor and 5 years data backup facility (8 TB), 55" LED Display, online 3KVA UPS and computer node, internet connection with requisite public IP address, firewalls and other required networking components with network wiring at state data centre, Bidhannagar, Kolkata that will support the reception of GSM, GPRS data directly from remote station & INSAT data from CWC ERS through Internet
- 5) Assure the collection, storage/backup and seamless flow of Real Time Data from all types of automated sensors to ERS at New Delhi and Bidhannagar.
- 6) Perform on-site assembly, start-up of the supplied goods.
- 7) Complete commissioning integration, testing & organization of the whole system. Bidder is responsible for, interfaces between the sensors and the DCP, DCP and transmission equipment and that between ERS, modelling centers & E-SWIS software, and ensure compatible data format as per bid document and trouble-free operation of system.
- 8) Provide operation & maintenance services during Five (5) years warranty period to include all components at the remote stations as well as all newly acquired equipment in the data center.
- 9) Provide installation and maintenance reports as required by the Purchaser and any delay is not acceptable in time schedule provided by supplier.
- 10) Supply on-site spares to repair any part of the remote stations upon determination of malfunction or failure. This includes, but is not limited to, DCP, sensors, batteries, solar panel and other accessories etc. required in seamless operation of the real time data acquisition system.
- 11) Supply detailed operation and maintenance manual for each component in the system and compile Knowledge and working supply type Manual for training purpose (including multimedia training kits).
- 12) Provide classroom and field trainings on the acquisition system to the sufficient number of personnel from **Irrigation & Waterways Department, West Bengal**. This includes operation and maintenance procedures. Training will have to be imparted at selected field locations as selected by the Purchaser. Provide formal and on-the-job training to purchaser's personnel at the plant & onsite. This includes startup, operation, maintenance and/or repair of

the supplied goods. Course topics will include sensor calibration, data logger configuration, data downloading, data retrieval, collection, Trouble shooting, processing maintenance requirements and procedure for equipment configuration, installation, site testing and commissioning including training kit containing course material in soft and hard copies.

- 13) Onsite Calibration and validation of the installed system shall be performed on half yearly basis which shall be continuous process during the entire warranty period .This will include calibration of gate sensors to obtain discharge passing through gates for dams/weirs and calibration of canals against water level to obtain discharge data.
- 14) All selected sites should conform to the extent practical to **WMO** guidelines. The purchaser will be responsible for obtaining permission to use property. River stage Reservoir Stage and weather data will be logged every 1 hour and transmit data based on a schedule set in the data logger (e.g. once an hour) and/or in case of GSM/GPRS communication the data transmission on an event (e.g. a measurement reaching programmed threshold values).
- 15) The remote stations (DCPs) shall store the data for at least one year.
- 16) To provide necessary facility to generate daily report of RTDAS data at specified time and in the specified format as prescribed by Engineer-in-charge
- 17) Bidder shall supply a detailed operation and maintenance manual for each appropriate unit of supplied goods and compile Knowledge and working supply type Manual for training purpose (including multimedia training kits).
- 18) To provide necessary facility to generate daily report of RTDAS data at specified time and in the specified format as prescribed by **Irrigation & Waterways Department, West Bengal**.
- 19) A guarantee by the manufacturer that all equipment being provided will have maintenance & Spare support for a minimum of ten years from the date of issuance of final acceptance certificate by engineer in charge including Warranty and Operation & Maintenance period;

4.0 GENERAL FEATURES/ SPECIFICATIONS

- i. It is imperative that all instrumentation, other equipment shall operate effectively with the DCP's and the DCP's in turn shall operate effectively with the satellite equipment and other systems of ERS. In addition, the input/output protocols of individual items of equipment (AWS, AWLR, ARG, DCP's, solar power arrangements, etc.) shall interface accurately. For this purpose, the interfaces between the sensors and the DCP, DCP and transmission equipment and that between ERS and modelling centers are ensured to be compatible and trouble free.
- ii. The specific electrical, electronic and mechanical design parameters mentioned in case of individual sensors are indicative of a typical design and variations therein can be considered provided the output, resolution accuracy and ruggedness against environment are not compromised in any manner. In such

- cases where the supplier proposes to deviate from the specifications a full technical justification shall be provided. The Purchaser is not bound to accept such justification.
- iii. It shall be the Suppliers responsibility to ensure that the installation is robust and shall continue to work in extreme weather conditions.
 - iv. Reliability of operation during normal and extreme weather conditions is imperative.
 - v. The sensors and all accessories and facilities shall be fully compatible with the data acquisition and transmission system. The sensors and DCP's shall form a complete automated data acquisition storage and transmission system.
 - vi. In case of any of the sensors, the equipment is supplied with certain optional features which are required to be ordered separately and are not included as a part of the offer; the same shall be clearly mentioned in the bid along with the functions of such features. The purchaser shall be provided with all necessary information which shall enable him to take an informed decision at the time of entering into the Contract as to the ordering any such feature or otherwise.
 - vii. The Bidder shall enclose technical literature with photographs in respect of all the sensors, datalogger and other equipment being quoted. The features which are mentioned in the literature but are not being quoted as a part of the current system shall be clearly brought out in the bid. In the event of failure of the Bidder to explicitly mention any such exclusion, it shall be taken as inclusion of all features mentioned in the bid as a part of the supply and the Bidder shall have to provide all such features/ accessories without claim of extra cost to the purchaser.
 - viii. Although all accessories and fixtures required for installation of the equipment & their specifications have been specified in technical specifications however, bidder shall ensure the satisfactory performance & functioning of RTDAS system complete, for this if any accessory or item s are required that shall be provided by bidder, the cost towards that is deemed to be included in the cost tendered by the bidder, no extra cost shall be paid to the bidder on this account.
 - ix. Bidders shall give general layout of all the installations including all civil works for types of stations and materials including that for the equipment at the time of bidding. Afterwards, the successful Bidder shall furnish the details of all the mounting arrangements, including civil works. Indian Standard codes of practice shall be followed for all civil works and mounting arrangements.
 - x. The security arrangement provisions for sensors installed in the open ground like Chain-Link fencing, locking etc. shall be provided by the Bidder.
 - xi. Security of installed equipment's including theft and vandalism will be the responsibility of the Bidder till successful installation, commissioning, two stages of site acceptance testing.
 - xii. All fixings shall be non-corrodible.
 - xiii. The Bidder has to specify how the calibration will be carried out and has to use his own calibration equipment during the period of warranty.

- xiv. Ensure that all software licenses and maintenance agreements are in the name of Purchaser and should seek full support and updates for such software for the duration of the **Warranty** Period. Also, all the software licenses should be valid for the design life of the system, that is 10 years from date of commissioning.

5.0 EQUIPMENT ARRANGEMENT AT REMOTE STATIONS

5.1 Automated Water Level Recorder(AWLR) for River /Reservoir:

The Automatic Water Level Recorder (AWLR) station shall be equipped with all necessary equipment's and peripherals including the following:

- i. Data Collection Platform (DCP) mounted inside an enclosure which will house the following items.
 - Data Logger with INSAT, GSM & GPRS Transmission facilities with built-in display.
 - Battery for power requirements
 - Pre-wiring and configuration.
 - Solar panel-based power supply system.
 - Antenna's (INSAT, GPS, GSM / GPRS) & required accessories
- ii. Installation of suitable range of Non- contact type Water Level Radar sensor for Automatic Water Level Recorder (AWLR) station with all fittings, accessories and cables and conduits.
- iii. At selected at stations, installation of Gate position sensor with all fittings, accessories and cables. Gate position sensor data shall be integrated with the AWLR datalogger and transmit.
- iv. Mast / tripod to mount DCP at the site (alternatively, where walled enclosure or tower is available, same can be mounted on the same.
- v. Mast / tripod for solar panel & INSAT antenna. (provided locally by the Bidder). Mast can be shared with the DCP mast also.
- vi. Civil works for mast (provided locally by the Bidder).
- vii. Conduit for cables GI Flexible conduits and HDPE pipe conduits.
- viii. Power & signal cables with cable conduits.
- ix. Grounding and lightning protection (provided locally by the Bidder)
- x. All necessary hardware required for the system to operate properly.

5.2 Automatic Rain Gauge:

The Automatic Rain Gauge shall be equipped with all necessary equipment's and peripherals including the following:

- i. Data Collection Platform (DCP) mounted inside an enclosure which will house the following items.
 - o Datalogger with INSAT, GSM & GPRS facilities for transmission of data with built in display.
 - o Battery for power requirements
 - o Pre-wiring and configuration.
 - o Solar panel-based power supply system.
 - o Antenna's (INSAT, GPS, GSM / GPRS)& required accessories.
- ii. Automatic Rain Gauge station will have Tipping Bucket Rain Gauge (TBRG) sensor with all fittings, accessories and cables. The rain gauge will be installed as per the WMO guidelines.
- iii. Mast /tripod to mount DCP at the site (alternatively, where walled enclosure or tower is available, same can be mounted on the same).
- iv. Mast/ tripod for solar panel & INSAT antenna. (provided locally by the Bidder)
- v. Mast can be shared with the DCP mast also.
- vi. Associated Civil works for installation of Rain Gauge(provided locally by the Bidder).
- vii. Conduit for cables GI Flexible conduits and HDPE pipe conduits.
- viii. Chain -Link fencing for ARS (5m * 5 m* 2 mheight) and gate with lock if required(provided locally by the Bidder).
- ix. Power & Signal cables with conduits.
- x. Grounding and lightning protection(provided locally by the Bidder).
- xi. All necessary hardware required for the system to operate properly.
- xii. The installation should be made as per WMO guidelines at standard height.

5.3 Automatic Weather Stations (AWS) with Pan Evaporimeter:

The Automatic Weather Station (AWS) shall be equipped with all necessary equipment's and peripherals including the following:

- i. Data Collection Platform (DCP) mounted inside an enclosure which will house the following items.
 - o Datalogger with INSAT, GSM & GPRS facilities for transmission of data with built in display
 - o Battery for power requirements
 - o Pre-wiring and configuration.

- Solar panel-based power supply system.
 - Antenna's (INSAT, GSP, GSM / GPRS)& required accessories.
- ii. Installation of Rainfall, Wind Speed & Wind Direction, Air Temperature & Relative Humidity, Solar Radiation, Air pressure sensor and standard size PAN evaporation sensor with all fittings, accessories and cables.
 - iii. Wooden Platform for installation of PAN
 - iv. Civil works for installation of PAN
 - v. Triangular Tower of 10m height with guy rope support & required mounting hardware to mount DCP & required sensors as per WMO guidelines for meteorological equipment's. (provided locally by the Bidder)
 - vi. Tower can be shared with the DCP mast also Tower can be shared with the DCP, solar panel & INSAT antenna.
 - vii. Associated civil Works for 10m Tower and guy support (provided locally by the Bidder).
 - viii. Conduit for cables GI Flexible conduits and HDPE pipe conduits.
 - ix. Chain-Link fencing (10m * 10m*2m height) and gate with lock if required (provided locally by the Bidder)
 - x. Power cables with conduits.
 - xi. Grounding and lightning protection (provided locally by the Bidder)
 - xii. All necessary hardware required for the system to operate properly.
 - xiii. Installation should be made as per WMO guidelines at standard height.

5.4 Automated Pan Evaporimeter System

- It consists of Evaporation Pan Standard National Weather Service Class A type for measurement of water evaporation.
- It is used to determine the evaporation rate by measuring the changing water level in an evaporation pan. A standard National Weather Service Class A Evaporation Pan is to be used. The Evaporation gauge is connected to the pan using the stainless-steel pipe and fittings.
- Wooden Platform for installation of PAN
- Civil works for installation of PAN
- Evaporation Pan Gauge shall be integrated with the AWLR /AWS data logger.

5.5 Shaft Encoders for Gate Positioning System

This category describes the requirement for sensors placed on gates such as spillway gates and irrigation outlets to measure gate openings. The measured gate opening will be used along with water elevation to determine accurate discharge passed through the gates.

Suitable sensors shall be provided for exact measurement & indication of position of

spillway radial gates, intake gates & silt flushing gates. These sensors shall be equipped with suitable shaft couplings and electronic circuits to transmit the signals to the datalogger for indication & for further processing. All sensors are to be mounted in the outdoor locations. Hence, suitable protection class of the enclosures shall be ensured. Minimum IP65 protection class shall be provided. Suitable safe & reliable arrangements of coupling with the lifting motors of gates shall be provided. It shall be ensured that there is no slippage between the motor shaft & the transducers.

The reservoirs namely Hinglow and Kangsabati will be provided both with spillway gate sensors and irrigation outlet sensors.

Bidder shall be responsible for all civil works related to the installation of the sensor, though plans for civil works must be approved by the Purchaser prior to the acquisition, installation and commissioning of the sensor. Regardless of the sensor solution, the flows past the gates must be accurate to within 5% of the actual flow.

The Shaft encoders for indication of reservoir gate position shall be equipped with all necessary equipment's and peripherals including the following

- i. Data Collection Platform (DCP) mounted inside an enclosure which will house the following items.
 - Datalogger with INSAT, GSM & GPRS facilities for transmission of data with built in display
 - Battery for power requirements
 - Pre-wiring and configuration.
 - Solar panel-based power supply system.
 - Antenna's (INSAT, GSP, GSM / GPRS)& required accessories.
- ii. Shaft Encoder based Rotary position sensor with all fittings, suitable shaft couplings, accessories and cables and conduits.
- iii. Mast/ tripod for DCP, solar panel & INSAT antenna.
- iv. Conduit for cables GI Flexible conduits and HDPE pipe conduits.
- v. Power & signal cables with cable conduits.
- vi. Grounding and lightning protection
- vii. All necessary hardware required for the system to operate properly.

5.6 TELEMETRY

The data communications employed on RTDAS network will use INSAT and GSM / GPRS radio communications. Both telemetry systems should work simultaneously for redundancy. It will be the responsibility of the bidder to confirm radio path and mobile network coverage. The bidder will be ultimately responsible for establishing data communication at all sites.

The bidder will provide all associated civil works related to the installation of the antenna, including cabling, wiring and other such infrastructure.

5.7 STATE DATA CENTER (SDC)

The State data center (SDC) is will be established at Data Centre Bidhannagar. The SDC will receive INSAT data from ERS at New Delhi/Jiapur/Burlathroughinternet and cloud service of e- SWIS.TheGSM/GPRS receiving station at SDC will receive GSM/GPRS data directly from remote stations. Both the type of data willbestored in the same data base server at SDC. Necessary equipment such as , , Server for GSM &GPRS data reception, High End workstation / Computer system, 55” LED Display, etc. will be installed at State data center,Bidhannagar.. The system shall be able to accept coded SMS messages from manually operated remote stations and as a back-up to the RTDAS systems.The components include GPRS communication system and workstation fordata collection /application /storage backup for the collection, quality. This infrastructure includes all networking devices to connect the equipment via INTRANET to the Web. The space needed for SDC will be provided by the purchaser.

5.8 GSM &GPRS Data Collection Station

- The GSM & GPRS data collection station shall be established at Bidhannagar.
- The GSM &GPRS data collection station will be able to interrogate the DCPs based on a schedule of the State’s choice and as implemented by the bidder.
- The GSM &GPRS Data Collection Station will also be able to receive data sent by the remote RTDAS stations whether the data is sent via SMS text or over GPRS internet connectivity.
- In case of failure of INSAT telemetry of remote RTDAS sites, the provision for polling the data by GPRS telemetry so that missing of data is avoided.
- The bidder will provide all civil works related to the installation of the antenna, including cabling, wiring and other such infrastructure required to operate the GSM & GPRS Data collection station.

5.9INSTALLATION REQUIREMENTS FOR RTDAS

SITE PREPARATION AND INSTALLATION

- The purchaser will provide details of the installation sites before the scheduled installation date to allow the Bidder to perform site inspection and construction of suitable structures before the installation of the hardware.
- The location of antenna, sensors and related civil work will be decided by the respective Site Engineer-in-chargeDependingon the site and river flow conditions.
- The Bidder should complete the required works at the site for proper installation of the equipment before receipt of the equipment.

- These are the basic guidelines for installation of RTDAS system however it may vary as per site conditions, in case of variation from installation guidelines stated below drawings shall be approved by engineer-in charge prior to the start of installation work

1. SPECIFICATIONS FOR INSTALLATION

i) Automatic Rainfall Station

ARG stations will require a hardened enclosure on a structure (pipes, mast, and tower) to make the enclosure stable. The enclosure will be mounted 1.5 m above the ground. The rain gauge will be placed away from objects such that the rain gauge orifice is no closer than the 2 times the difference in height (top of the rain gauge to the top of the nearby objects) to other objects. Latest IS standards & WMO guidelines are required to be followed for ARG installation.

ii) Automatic Water Level Recorder (AWLR) for River and Reservoir

SAFETY REQUIREMENTS

- The sensor and its accessories should be protected from theft. The bidder is encouraged for minor modifications in installation of sensor and its accessories so as to minimize the chances of theft. Mortise lock is proposed to avoid theft. Due care must be taken while modifying the installations. In no case the basic principle and working of sensor is allowed to disturb.
- Radar sensors should be mounted such that they have a direct vertical shot to the water surface with no obstruction of their beams. Beam spread must be determined based on manufacturer's specification and the maximum expected distance to be measured at low flows. Consideration should be made in designing the mounting structure to allow for easy access to the instrument for maintenance
- Framework support to attach Radar sensor to Bridge Tower.
- Framework support made of fabrication of M.S. Angle 50mm x 50mm x 5mm with gusset plate 8mm thick (0.85m x 0.3m) including welding, riveting, anticorrosive paint, colour etc. complete as per FIG

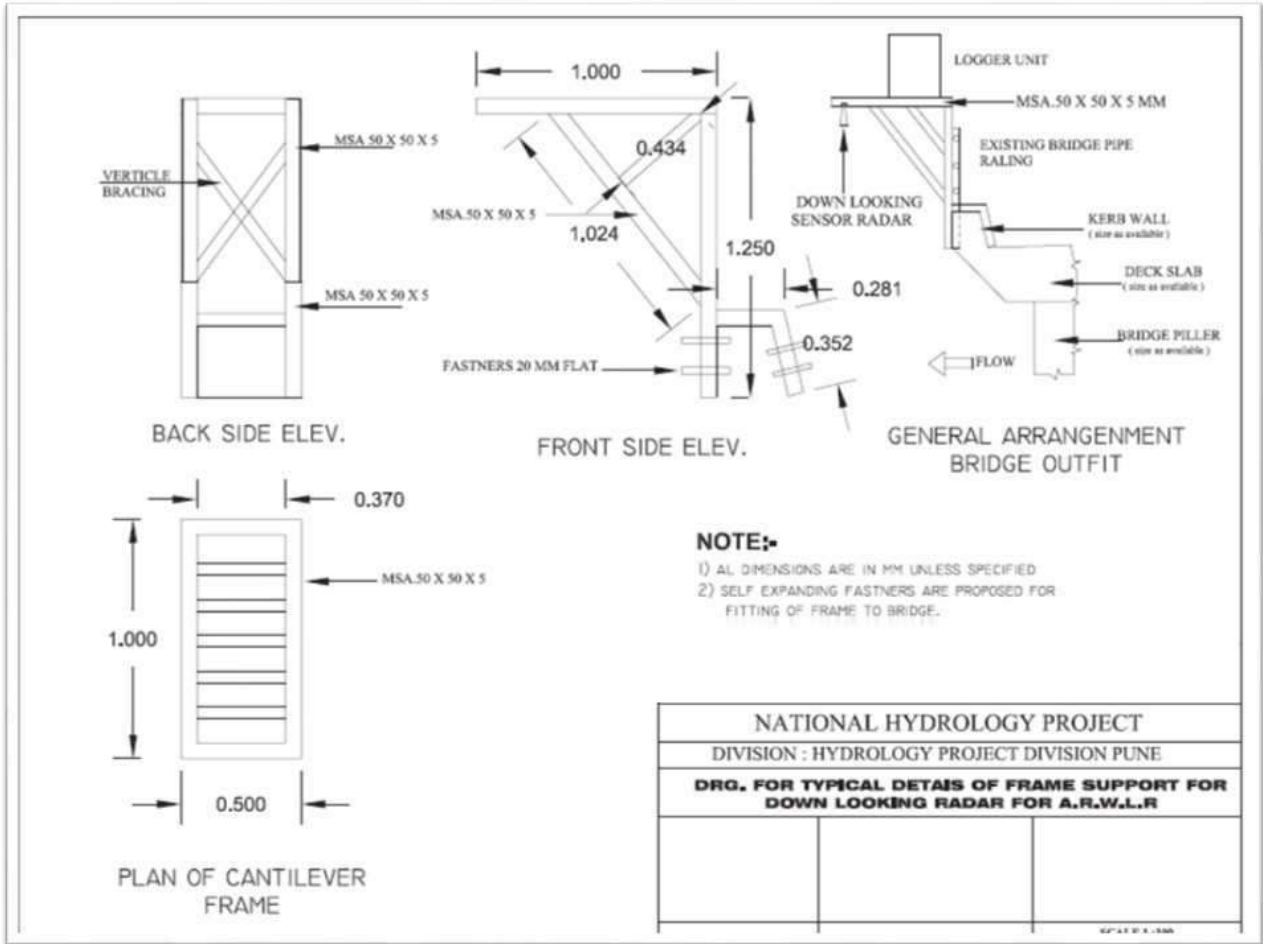

iii) Automatic Weather Station

AWS stations will be placed in open fields and away from any obstructions which may disturb the measurements. WMO guidelines will be followed during the installation and precise site selection. The AWS stations will require a 10mts tower. The hardened enclosure will be attached to the tower at 1.5 m about the ground. Then Air Temperature/Relative humidity and Solar Radiation sensor will be mounted at ~1.5 m above the ground and sufficiently away from any objects that may produce long wave radiation. The wind speed/direction sensor will be place that the top of the 10 m tower. The rain gauge will be placed away from the tower, at least 3 m from the tower, and no closer than the 2 times the difference in height (top of the rain gauge to the top of the nearby objects) to other objects. .Latest IS standards & WMO guidelines are required to be followed for AWS installation.

iv) Specifications for Civil Works

Common Enclosure for Site

Area of the ARG and AWLR Station should be ideally 5m * 5m * 2m height. If a rare condition demands then even lesser area (5 m * 4 m) can be demarcated in consultation with officials.

Area for Automatic Weather Station (AWS) should be ideally 10m * 10m * 2m height, If a rare condition demands then even lesser area (8m * 8m) can be demarcated in consultation with officials.

The approach to the site should be made free of obstacles like bushes; trees etc. and a suitable cement path must be laid to approach the platform.

Following are the common specification for civil works for all the Telemetry sites.

Fencing for site

- The height of the fencing for the site must be 2 meters from the ground level.
- The fencing must be made over a Concrete foundation which is 230mm above ground level.
- Fencing angle should be of size 40mm x 40mm x 6mm and pre-coated with red-oxide.
- The total length of the fencing angle should be 2.8 meters i.e. (2.0m above ground level + 0.8 m below ground level)
- Two MS angles must be used diagonally at each of the four corner angles of the site. The angles can be attached (with welding or the other appropriate means) from the middle of the existing corner angle to the ground. The depth of the support will remain the same as of main angle.
- The dimensions of the fencing angle foundation should be 450mm x 450mm (length X width) and at a depth of 800mm. The foundation should be square shaped. Distance between each fencing angle should be 1.5 to 2 meters.

Chain-link

- Dimensions of GI Chain-link: 3 inches x 3 inches and of Gauge: 10 (3 mm diameter).
- GI chain-link mesh must be stretched and welded/fixed properly on the fencing angles.
- A pipe or angle must be fixed on the upper part of the fencing to have a neat finishing and at the same time to avoid loosening of the fencing over a period of time.
- The chain-link fencing should be fastened with the help of screws fitted on the fencing angles. Alternately it may be welded neatly at four equidistant positions of 0.5 m each.

Gate

- Dimensions: 1 m X 2 m (Width x Height) with locking facility
- The gate must be fabricated by MS Angle whose dimensions should be minimum 40mm x 40mm x 6mm
- Suitable locking facility with 3 keys for safety purposes is mandatory. Standard locks should be used.
- Gate and MS Angle must be well painted with white / silver colour.
- Gate should have proper support of MS angles with additional support of crossed MS angles. Alternately gate should be fixed with the support of RCC pillars.

Rain Gauge and WL sensor Foundation

- Rain gauge foundation must be of dimensions 450mm x 450mm (length x width) and 800mm deep.
- The rain gauge may be located so that it is at a minimum distance of 2 m away from obstructions on all four sides.
- The raised platform should be 230mm above the ground level.
- The orphic rim of rain gauge should be 1.0 to 1.2 meters above ground level. In the case of flood prone areas, the base plate on which the rain gauge is mounted should be placed 1.0 m above ground level. The location must be decided after discussion with Field Officer.

Mast Foundation

- Foundation Dimensions: 750mm X 750mm (length x width) and 1.2m deep. The raised platform of the foundation must be 300 mm above the ground level.
- The height of the mast should be minimum 3 meters above raised platform.

10mts Tower Foundation

- The 10m triangular tower foundation must be of dimensions 900mm X 900mm (length x width) and 1.5m deep. The raised platform of the foundation must be 300mm above the ground level.
- Proper guy rope support (three Nos) with foundation (for 10mts Tower). The foundation for the Anchor Rod which holds the guy rope must be of dimensions 450mm X 600mm (length x width) at the ground level and min 1.2m deep
- The DCP, sensors and Antenna will be mounted on a 10-meter triangular tower, which should cater for fitments of assemblies for sensors, DCP, antenna and other accessories. The tower will have 3 sections of 3 meter height and one top section of 1-meter height. The tower should be made of MS Pipe and should be light as well as robust enough to withstand weight of at least two

persons (200 Kgs). This tower with complete accessories will be part of the supplies and will be galvanized to avoid rusting and long life in outdoor conditions.

Proportions for concrete foundations

- Concrete pillar foundations for the (RTDAS) mast/tripod/tower, fencing angle should be made in the volumetric mixing proportions as follows:
- Concrete foundation: 1 (Cement): 2 (Sand): 4 (Metal)
- Fine plastering: 1 (Cement): 3 (Sand)
- Concrete Pillar must be cemented to achieve smooth finish above the ground level.
- After 8 hours, these foundations should be cured with water at least 3 times a day for four days.

Local Earthing

- Material required: Salt: 20 Kg; Charcoal: 20 Kg; Sand 100 Kg
- The lightning arrestor rod is made of copper which is mounted on the top most part of the RTDAS Mast / Tripod /tower.
- It should be of thickness 12 mm and of one-meter length with a connected copper wire of 6mm thickness (gauge). At the other end of copper wire is the Earthing rod of dimensions 15mm thickness and 1.8-meter length, which is buried into the ground.
- On the bottom of earthing rod, one copper plate of dimensions 300mm x 300mm should be connected. RTDAS Data logger enclosure should also be grounded with local earthing.
- A pit of 1200- 1500 mm depth, 600 x 600 mm wide at bottom (like a cone shaped pit) has to be dug.
- After leveling the bottom of the pit, uniform layer in the sequence of 150 mm of Salt + 150 mm Charcoal + 150mm Sand is filled. Such sequence is repeated 3 times till the earth pit is filled to the top. The copper earthing rod is placed in the center of the pit. The pit is closed and leveled.

Painting

- The tower, fencing angles, chain-link fencing and gate should be properly painted with one coat of red lead oxide primer & two coats of silver paint every year to avoid rusting.
- All concrete foundations shall be painted using white cement paint every year.

6.0 TECHNICAL SPECIFICATION

6.1 Radar Type Water Level Sensor (0-35m)

Functional Requirement: To measure the water level

Design Requirements: The equipment offered should conform to the following technical specifications:

Feature	Value
Site Conditions	
Ambient Temperature	From -5 to +60 Degree Celsius
Humidity	0 to 100 %
Altitude	0 to 2500 meter
Sensor	
Sensor Type	Microwave non-contact sensor
Range	35meters
Resolution	3 mm or better
Accuracy	0.02 % FSO
Output Interface	SDI-12 / RS-485 / 4-20mA
Power Supply	To be powered by Solar Panel provided by bidder with DCP
Beam angle	Less than 16degrees
General Features	
HousingMaterial	Corrosion Resistance (Stainless steel / Aluminum /PVC/UV stabilized ABS with metal casing)
Enclosure	The Sensor shall be easy to dismount and replace in the event of malfunction.
Tools	Complete tool kit for operation and routine maintenance
Manuals	Full Documentation and maintenance manual in English
Accessories	Sensor Mounting support, cables and other accessories as required
Protection	NEMA 4 or IP67 or better
Horizontal Mounting/Installation Arrangements	Above FRL, below a bridge girder wherever available otherwise horizontal cantilever arrangement from a mast/wall/pedestal to be provided
Radar Sensor should have inbuilt diagnostic feature & averaging function	

6.2 Automatic weather stations with PAN Evaporimeter

FUNCTIONAL REQUIREMENT: To measure the weather parameter

DESIGN REQUIREMENTS: The equipment offered should conform to the following technical Specifications:

Feature	Value
Site Conditions	
Ambient Temperature	From -5to +60° C
Humidity	5 to 100 %
Altitude	0 to 2500 meter
Air Temperature Sensor	
Sensor Type	Platinum resistance or better or equivalent
Range	-5 to 60 Degree Celsius
Resolution	0.1°C
Accuracy	Within ±0.2°C in the entire working range
Response Time	10 secs or lesser
Relative Humidity Sensor	
Sensor Type	Capacitive/ Solid State Humidity Sensor
Range	0 to 100 %
Resolution	1%
Accuracy	±3% or better
Response time	10 secs or lesser
General	
Self-aspirated	To ensure continuous supply of air. Free from turbulence, water droplets and radiation
Power Supply	To be powered by solar power provided by bidder.
Accessories	All accessories for mounting the instrument at ~1.5mts height above the ground levele.g. special cross arm clamps or flag, if any shall be provided
Output Interface	SDI-12/ RS-485/ Analog
Wind Speed and Direction Sensor	
Sensor Type	Ultrasonic sensor (No moving Parts)
Range	0-60 m/s for speed and 0–360 degrees for direction or better

Resolution	0.1m/s for Speed; ± 1 degree for Direction
Accuracy	Wind speed $\pm 2\%$ ± 0.1 m/s (up to 20 m/s) and $\pm 3\%$ (for 20 to 60 m/s) Wind Direction $\pm 1^\circ$ or better
Response time	Less than 1 second lag in operating range
Mounting	All accessories for mounting the instrument at 10mts height above the ground level, e.g. special cross arm clamps or flag if any shall be provided.
Output Interface	SDI-12 / RS-232/ RS-485
Air Pressure Sensor	
Sensor Type	Temperature Compensated
Range	600 to 1100 hPa
Resolution	± 0.1 hPa
Accuracy	± 0.2 hPa
Power Supply	To be powered by solar power provided by bidder
Output Interface	SDI-12 / RS-232/ RS-485
Solar Radiation Sensor	
Sensor Type	Silicon Pyranometer
Threshold	120 W/m ² of direct solar irradiance
Methodology	Alternate shading of sensor to account for sky radiation or Sunshine duration shall be computed in datalogger
Spectral Range	400nm to 1100 nm
Range	0-2000 W/Square meter
Resolution	1 W/Square meter
Accuracy (Including Temperature Compensation)	3% or better
General Features	
Material	Corrosion Resistance Metal (Stainless steel / Aluminum)
Tools	Complete tool kit for operation and routine maintenance
Manuals	Full Documentation and maintenance manual in English
Accessories	All accessories for mounting the instrument at ~1.5mts height above the ground level e.g. special cross arm clamps or flag, if any, shall be provided.
Output Interface	SDI-12/RS-485/4-20 mA/Analog
Evaporation- Pan specification	

Operating temperature	-5 to 60 degrees Celsius
Operating Humidity	5 to 100 %
Altitude	0 to 2500 meter
General Features	
Measurement	Evaporation Pan with water level sensor
Sensor Type	Shaft Encoder / ultrasound radar / Float & pulley type As Specified by IS:5973 which known as the modified Class A Panevaporimeter
Diameter of the pan	1.2 m or more
Accuracy	± 1% FSO
Resolution	1mm
Power Supply	To be powered by solar power provided by bidder
Accessories	As required for complete installation of the sensors and equipment
Material	The pan is made of Copper or anti corrosive stainless-steel, tinned inside and painted white outside.
Covering	The top of the pan is covered with a hexagonal wire net of GI to protect water in the pan from birds
Platform	Rot resistance, timber treated with creosote or other effective Wood preservative
Measurement range	150mm
Output Interface	SDI-12 / RS-485 / 4-20 mA / Analog

6.3 Automatic Rain Gauge

FUNCTIONAL REQUIREMENT:

- Rainfall shall be measured using the tipping bucket method and shall be able to record cumulative rainfall.
- A spout filter shall prevent ingress of insects and debris.
- IMD/WMO certification is required.

Feature	Value
Site Conditions	
Ambient Temperature	From -5to +60 Degree C
Humidity	5 to 100 %
Altitude	0 to 2500 meter
Sensor	

Sensor Type	Tipping Bucket type with reed switch
Range	250 mm/h or better
Resolution	0.5 mm or better
Accuracy (Intensity)	2% or better, ± 2 mm
General Features	
Output Interface	SDI12/ RS-485 / 4-20 mA/Switching closure output
Power Supply	To be powered by solar power provided by bidder
Material	Corrosion Resistance Metal (Stainless steel/ Aluminum)
Enclosure	NEMA 4 or IP65
Tools	Complete tool kit for operation and routine maintenance
Manuals	Full Documentation and maintenance manual in English
Accessories	Sensor Mounting support, cables and other accessories as required
Certification	IMD/ WMO certification shall be provided.

Note: Bidder shall provide spout filter and bird cage to prevent ingress of insects and debris , And with Bubble Spirit Level and adjustable legs for horizontal alignment of tipping bucket mechanism

6.4 Gate Position Measuring System (Shaft Encoder Type)

FUNCTIONAL REQUIREMENT: Gate sensors shall be installed on gates to measure gate opening.

DESIGN REQUIREMENTS: The equipment offered should conform to the following technical Specifications:

Feature	Value
Site Conditions	
Ambient Temperature	From -5 °C to +60 °C
Humidity	5 to 100 %
Altitude	0 to 2500meters
Sensor	
Sensor Type	Shaft Encoder based rotary optical/magnetic Absolute encoder position sensor
Range	1-20 meters
Resolution	3 mm or less

Accuracy	0.025 % FSO
Output Interface	SDI-12 / RS-485 / 4-20 mA
Hardware/ Ports/accessories	Communication ports compatible with data logger,
General Features	
Power Supply	To be powered by Solar power system provided by bidder
Material	Corrosion Resistance Metal (Stainless steel or Aluminium)
Enclosure	Outdoor environment with corrosion resistant material Lockable (key) box provided by the supplier to be mounted on Gate sensor, with IP65 or better
Tools	Complete tool kit for operation and routine maintenance
Manuals	Full Documentation and maintenance manual in English
Accessories&Mounting	Wiring from sensor to Datalogger must be through HDPE/ GI Pipe Conducting and flexible metallic conduiting wherever applicable, Sensor mounting support/clamps, limit switches& cabling etc.
Process connections	through suitable coupling
Manufacturer's Calibration Certificate	Required

6.5 Data Logger with 8 AI channels

Feature	Value
Site Conditions	
Ambient Temperature	From -5 to +60 Degree C
Humidity	5 to 100 %
Altitude	0 to 2500meter
Sensor Interface	
Analogue Inputs	8-Analogue Input Channels 4 to 20 mA, 100% over range withstand (Analog input channels are required in datalogger, if any sensor offered by bidder requires Analog interface to integration with datalogger)
SDI Port	One SDI-12 Interface port
Serial Port for sensor interface	One RS-232 for sensor Interface One RS-485 for sensor Interface port
Pulse Input	1Input for Rain Gauge impulse

Input - Output Interfaces	
Data Transfer	USB stick option for Data transfer
Port for Configuration	One Serial Port (RS-232 /USB) for communication with Laptop for programming
Port for Telemetry	2 Ports for Communication with Telemetry (GSM,GPRS and INSAT) device Both telemetry systems should work simultaneously for redundancy.
Display Port	Port for connecting external display screen for data in running text
Computer Software	
Operating System	Windows software for system configuration / communication
Version	English language version
Licenses	All required licenses shall be included
Analog to Digital Converter	
Resolution	16 bit or better
Conversion Accuracy	± 1 LSB
Sample intervals	1 Sec to 24 hours (user scalable)
General Features	
Flash memory	Non-volatile Flash memory that can store one year of data. & expandable upto a minimum 1GB Via USB/SD Card.
Resolution	A/D resolution ≥ 16 bit
Recording Interval	Individual recording intervals for each sensor/parameter
Firmware Operating System	Multi-tasking operating system - must log data and transmit at same time
Display	Inbuilt Digital Display for viewing current data and setting values
Power Supply	Shall be powered by solar Power supply to be provided by bidder with DCP, low current drain (quiescent ≤ 10.0 mA)
Battery Voltage	Monitoring of battery voltage level
Internal battery	Internal battery backup for clock, lithium battery, storage 2 years
Charge Controller	Internal or External
User Permissions	Different user levels, system of user rights / passwords, access restricted to unauthorized personnel
Internal clock	Internal clock with drift less than 1 second per Week
Keypad	For displaying or transferring data to memory stick, configuration of data logger and sensors
Real time clock	GPS synchronized & timing in IST format required
System integrity	System integrity check procedures

Enclosure	for wall-mounting in a shelter / enclosure with IP65 (NEMA 4 or equivalent) protection or better
Accessories	Serial cable + adaptor (if required). All accessories (fixing units, etc.) as required
Tools	complete tool kit for installation and routine maintenance giving full detail (number of pieces and type)
Manuals	full documentation and maintenance instructions in English (1 copy per station).
GSM /GPRS MODEM	
Ambient Site Conditions	
Operating Temperature	From -5 to +60° C
Performance	Data Reception availability of 95% or better
Form factor	The GSM /GPRS modem should either be integral part of data logger specified above, or it should be supplied as independent unit compatible with supplied data logger
Specific Features	
Communication Direction	Utilize GPRS network for two-way connection with FTP, TCP/IP (INTERNET) connection and SMS
Transmission trigger	Data collection to be triggered by interrogation from Data Center, or by event-based transmission triggered by remote site
Power Saving	Ability to disable interrogation system in order to save power at remote site
Communication Protocol	Data transmission to execute HTTP Post, FTP, SMS to transmit and receiving data to the Data Center
Accessories	All associated equipment, including Antenna all cables and mounting hardware
Antennafeatures	
Frequency range	900 MHz: 824-960 MHz/1800MHz:1710-1880 MHz, 4G and better
Impedance	50 ohms
VSWR	≤ 2.0
Radiation	Omni-directional
Operating temperature	-5 to + 60 degrees Celsius
Connector	SMA or suitable RF connector adaptable to GSM/GPRS modem
Cable length	As required at site

6.6 Data logger with 2 AI channels

Feature	Value
Site Conditions	
Ambient Temperature	From -5to +60 Degree C
Humidity	5 to 100 %
Altitude	0 to 2500meter
Sensor Interface	
Analogue Inputs	2-Analogue Input Channels 4 to 20 mA, 100% over range withstand (Analog input channels are required in datalogger, if any sensor offered by bidder requires Analog interface to integration with datalogger)
SDI Port	One SDI-12 Interface port
Serial Port for sensor interface	One RS-232 / RS-485 for sensor Interface port
Pulse Input	1 Input for Rain Gauge impulse
Input - Output Interfaces	
Data Transfer	USB stick option for Data transfer
Port for Configuration	One Serial Port (RS-232 /USB) for communication with Laptop for programming
Port for Telemetry	2 Ports for Communication with Telemetry (GSM,GPRS and INSAT) device Both telemetry systems should work simultaneously for redundancy.
Display Port	Port for connecting external display screen for data in running text
Computer Software	
Operating System	Windows software for system configuration / communication
Version	English language version
Licenses	All required licenses shall be included
Analog to Digital Converter	
Resolution	16 bit or better
Conversion Accuracy	± 1 LSB
Sample intervals	1 Sec to 24 hours (user scalable)
General Features	
Flash memory	Non-volatile Flash memory that can store one year of data. &expandable upto1GB Via USB/SD Card.

Resolution	A/D resolution ≥ 16 bit
Recording Interval	Individual recording intervals for each sensor/parameter
Firmware Operating System	Multi-tasking operating system - must log data and transmit at same time
Display	Inbuilt Digital Display for viewing current data and setting values
Power Supply	Shall be powered by solar Power supply to be provided by bidder with DCP , low current drain (quiescent $\leq 10.0\text{mA}$)
Battery Voltage	Monitoring of battery voltage level
Internal battery	Internal battery backup for clock, lithium battery, storage 2 years
Charge Controller	Internal or External
User Permissions	Different user levels, system of user rights / passwords, access restricted to unauthorized personnel
Internal clock	Internal clock with drift less than 1 second per Week
Keypad	For displaying or transferring data to memory stick, configuration of data logger and sensors
Real time clock	GPS synchronized & timing in IST format required
System integrity	System integrity check procedures
Enclosure	for wall-mounting in a shelter / enclosure with IP65 (NEMA 4 or equivalent) protection or better
Accessories	Serial cable + adaptor (if required) for notebook connection. All accessories (fixing units, etc.) as required
Tools	complete tool kit for installation and routine maintenance giving full detail (number of pieces and type)
Manuals	full documentation and maintenance instructions in English (1 copy per station).
GSM/GPRS MODEM	
Ambient Site Conditions	
Operating Temperature	From -5 to +60 ^o C
Performance	Data Reception availability of 95% or better
Form factor	The GSM /GPRS modem should either be integral part of data logger specified above, or it should be supplied as independent unit compatible with supplied data logger
Specific Features	
Communication Direction	Utilize GPRS network for two-way connection with FTP, TCP/IP (INTERNET) connection and SMS
Transmission trigger	Data collection to be triggered by interrogation from Data Center, or by event-based transmission triggered by remote site
Power Saving	Ability to disable interrogation system in order to save power at

	remote site
Communication Protocol	Data transmission to execute HTTP Post, FTP, SMS to transmit and receiving data to the Data Center
Accessories	All associated equipment, including Antenna all cables and mounting hardware
Antenna features	
Frequency range	900 MHz: 824-960 MHz/1800MHz:1710-1880 MHz, 4G and better
Impedance	50 ohms
VSWR	≤ 2.0
Radiation	Omni-directional
Operating temperature	-5 to + 60 degrees Celsius
Connector	SMA or suitable RF connector adaptable to GSM/GPRS modem
Cable length	As required at site

6.8 Specifications for LED Running Text Display Unit

Functional Requirement: To be interfaced with datalogger to display the Hydro-Meteorological parameters test string

Design Requirements: LED Running Text Display unit should be used in Indoor and outdoor application and offered equipment should conform to the following technical Specifications:

Feature	Specification
Site Conditions	
Ambient Temperature	From -5 to +60 °C
Humidity	5 to 100 %
Altitude	0 to 2500 meter
General Features	
Size	4' (W) X 7" (H) or better
Pixel Pitch	8 mm or narrower
Maximum brightness	2000 cd/m2 meter
Colour	Red / Amber
Viewing Distance	≥10m
Optimum View Angle	Horizontal 120°; Vertical 60°
Ingression proof	IP 65 or better
Text Lines	One Line display

Refresh rate	300 to 2000 hertz
Input Voltage	220 ± 20 Volt AC
LED life	50,000 hours or better
Communication Port	Digital port RS-485 or RS-232 (user settable) Display unit should be interface with display port of RTDAS datalogger to display the Hydro-Meteorological Data string in running text with user selectable speed.
Programming	Configuration Through software to be part of supply

7.0 DATA COLLECTION PLATFORM

7.1 Functional Requirement

1. The system shall automatically collect the observations from attached sensors, process and store them into its memory and transmit through GSM /GPRS communication link to central station as per the preprogrammed measurement interval, and also system shall transmit hourly basis data of every full hour IST to the ERS through satellite at preprogrammed transmission time
2. The DCP shall also continuously monitor the status of the instruments, power supply and communication. In the event of failure of an instrument or disruption of any of the power sources, an alarm shall be sent back to the State data center.
3. The sensor's signal conditioning unit should be an integral part of the system.
4. The number of analog/ digital/ SDI-12 /RS-232 / RS-485 channels in the data logger must be compatible to the sensors being supplied and also for other battery monitoring systems
5. The System shall have provision to easily include and change the following information in field as mandatory requirements:
 - Unique station identification code.
 - Time of observation and Transmission.
 - Sensor identification
 - Data transmission time for INSAT & GSM/ GPRS communication
 - Programmable Sensor data measurement interval
 - Configuration of Measurement, logging & GPRS/GSM data transmission interval
 - Gain, offset, Datum parameterization for all sensors
 - Configuration of FTP server & mobile number of data center.
6. Parameterization & configuration of RTDAS stations remotely through GPRS/ GSM communication shall be available
7. The system shall have an integrated microprocessor-based data acquisition and

storage system having adequate hardware configuration and software support to serve as an interface between sensors and the communication link to perform tasks as stated below.

8. Providing necessary electrical power to the sensors and conversion of electrical output signals from the sensors into engineering value based on calibration information stored in the memory. Full compatibility with all types of sensors provided in the package is mandatory.
9. Storage of observed data along with time for all the parameters in the memory. Memory capacity to retain at least 365 days data is required. Data shall be available even if the power supply to the system has failed (RAM Backup battery) for one year
10. The stored data shall be retrievable via serial port to a PC/ laptop or USB device. The downloaded data shall be provided in the prescribed format provided for GSM/GPRS in technical specifications
11. Full compatibility with all types of sensors provided in the packages shall be mandatory.
12. The system should be stand alone and all programming functions / setups to be carried out through system keypad and display independent of a PC / Laptop.
13. The system should be capable of continuous updating of the values of sensed parameters and post processing the instantaneous values into average values over a specified period of time for transmission to the DCP with earth receiving station.
14. Management of DCP transmitter to optimize the battery consumption
15. The system shall provide a complete health status of the battery, transmitter and other components
16. The system shall support the following functions:
 - Easy programming set up.
 - Multi-tasking capability.
 - User friendly software programming.
 - The system shall have self-diagnostic facility and be capable of displaying station ID / sensor ID code and messages of the display panel for general identification of the fault. It should have facility to monitor these code and other health status through an external laptop / PC.
 - Setup shall be organized in a tree of menus and sub menus. Protection of setup parameters and data through password should be supported by the system. In addition, the DCP shall support the manual entry of data through keyboard and its display.
 - Data including the setup and program files shall be transferable from the system via. serial port to PC and SD card or other suitable memory device and vice versa. The scripts / software for configuration of datalogger should be part of supply.

- Facility for Pooling of data via GPRS shall available in datalogger
17. The DCP shall be housed in a weather proof and temper proof housing of NEMA 4 or equivalent type enclosure of steel or fiber glass
 18. DCP Should be supplied with Software for configuration and troubleshooting
 19. The data logger shall be programmable locally in field via laptop / PC.
 20. The DCP shall be located in a place specified by the Engineer-in-charge at each site and shall be generally one meter above Highest Flood Level (HFL) attained at that site. The DCP at each site shall be located in such a way it is easily approachable even in floods.
 21. The surge suppression in form of fuse or other appropriate device shall be provided for all interfaces to protect the data logger from the surges emanating from the sensors.
 22. Datalogger shall have a provision to display, store and transmit the water level with respect to MSL or with respect to zero level/bed level (user selectable).
 23. The datalogger shall store data in memory, in case of GPRS/GSM communication failure. The data shall be transferred automatically once GPRS/GSM communication is retained. This will ensure no data loss during no communication also.

7.2 Technical Specification

7.2.1 INSAT Radio

FUNCTIONAL REQUIREMENT: To transmit data

DESIGN REQUIREMENTS: The equipment offered should conform to the following technical Specifications:

Feature	Value
Operating Temperature	From -5 to +60 ⁰ C
Environment Relative Humidity	0 to 100 %
Carrier Frequency	402 – 403 MHz
Carrier Settability	In steps of 100Hz from 402.0 MHz to 403.0 MHz
Modulator	PCM/BPSK
Data coding	NRZ (L)
Output Power	3-10Watt, user settable
Data Bit Rate	4.8 kbps
Frequency Stability	
a. Long Term	Transmit frequency inaccuracy including aging of oscillator should not exceed ± 400 Hz per year. Oscillators/synthesizer should have provision to adjust for the long-term drift.
b. for temperature	± 1 ppm or better (-40 to +55 degrees Celsius)
Signal Bandwidth	6.0 KHz maximum or better
Power Stability	± 1 dB

Spurious	-60dB or better
Harmonics	-40dB or better
Antenna cable	LMR 400 grade or better
Performance	Data Reception availability of 99% or better
Form factor	The Transmitter should either be integral part of data logger specified above, or it should be supplied as independent unit compatible with supplied data logger
Operating Power	Switched 12V DC controlled by data logger
Yagi Antenna	
Polarization	LHCP or RHCP, switchable in field
Gain	Minimum 11 dbi or better
Center Frequency	402-403 MHz
Mounting	Proper mounting and Pointing arrangement for 360-degree azimuth and elevation adjustment
Operating Wind speed	250 kmph
Wind Survival	300 kmph
Material	Rust-proof and Oxidation-proof
Specific Features	
Satellite System	INSAT Radio System to be Used on the INSAT Satellite operated by ISRO
Certification	Certificate of acceptance required by ISRO or IMD as part of the bid package
Accessories	All associated equipment, including GPS, GPS Antenna, INSAT Antenna, all cables and mounting hardware

8.0 TRANSMITTER & ANTENNA

The INSAT transmitter should be an internal or external component of DCU. It should have necessary hardware and software to receive data from the data logger and transmit in TDMA mode. The transmitter should have the capability to handle data transmission to the DRTs located on any of the INSAT series of satellites. The selection of frequency and mode of transmission shall be through software settings only. No hardware changes for switching from one satellite DRT to another are acceptable.

8.1 Antenna features

- i. The tenderer shall ensure compatibility of the antenna in the entire system and also ensure achievement of objectives given in the telemetry link calculations to be provided by the tenderer.
- ii. The antenna should not allow accumulation of rain water, there by degrading its performance.
- iii. The antenna shall have a proper mounting and pointing arrangement suitable for transmission to any one of INSAT satellites-based DRTs (located anywhere in the geostationary arc from 45°E to 115°E longitude). The tenderer shall also provide suitable templates and fixtures/ tools for reorienting of the antenna towards any satellite by the field personnel as and when required.

- iv. Proper lightning and surge protection shall be provided to protect all the equipment connected to the antenna from atmospheric hazards. This arrangement shall be in addition to the general arrangement already covered under general scope of the work.
- v. Antenna to be designed with an optimum size so that it could be easily transported to remote and inaccessible places. Mounting of antenna should take care of Azimuth and Elevation changes. Systems have to operate in harsh and saline conditions and adaptable to tropical conditions.
- vi. The following technical features shall be supplied by the tenderer in addition to the technical information being provided by him as part of the Tender.

- a. Polarization : LHCP and RHCP (Switchable in field)
- b. Gain : Minimum 11 dBi or better
- c. Center frequency : 402.50 MHz
- d. 3dB Beam width : 40°
- e. VSWR : 1.2: 1
- f. Impedance : 50 ohms
- g. Axial Ratio : To be specified by tenderer
- h. Operating wind speed : 250 kmph
- i. Wind Survival : 300 kmph
- j. Material : Rust-proof and oxidation-proof for use in coastal and saline areas
- k. Connector type : Compatible
- l. Mounting : Should have engraved elevation angle marking
- m. Operating temperature : -10°C to +60°C
- n. Operating Relative Humidity : 0 to 100% RH
- o. Weight : Light weight
- p. Size : Small, portable
- q. Operating rain rate : 100 mm/hr and water proof
- r. Mounting /Installation arrangements : Mounting shall be done on a mast with sufficient foundation and structural strength

9.0 INSAT COMMUNICATION SYSTEM

9.1 Time Division Multiple Access (TDMA) Scheme

Each TDMA type of transmitting system shall have a unique GPS synchronized time of transmission which must be stamped on the body of the system by the manufacturer. The burst data format is shown in Fig (1). However, CRC is added to the data frame and half rate convolution coded. It is then appended with CR & BTR preamble and UW and transmitted in TDMA mode. Burst duration is 186 milli sec.

The TDMA frame format is shown in Fig (2). TDMA technique is an open loop system with timing derived from GPS receiver which is part of the RTDAS system. TDMA frame duration is one hour. The one hour frame is divided into 2 time windows, each of 30-minute duration. Each RTDAS system is assigned 1-second time slot in first 30-minute slot and the repeat transmission is after 30 minutes, which falls in the next time slot.

The one second frame is worked out taking into account the following details:

- 20 millisecond differential propagation delay over coverage area.
- RTC clock accuracy around 150 milliseconds per day – GPS receiver updates RTC once every twenty-four hours to conserve battery power of RTDAS system.
- GPS receiver accuracy of less than 1 microsecond
- Guard time required in the present burst receiver at Hub station.

9.2 Features of ISRO TDMA transmission

Features of ISRO TDMA transmission scheme are provided for general guidance. However international norms applicable for TDMA may be followed.

- Total number of RTDAS that could be accommodated in a single carrier is 1800.
- By including CRC in the data frame, data validity could be ensured.
- With preserving BCH coding of SID, data quality could be checked and valid data retrieved even for the bad CRC.
- By preserving present SID (Station Identification Code) structure of IMD, SID for all users of DRT could be standardized. The SID consists of 21 bits (9 bits for user type, 2 bits for priority, and 10 bits for Platform ID)
- With Forward error correction convolution coding, better data quality is ensured.
- With one repeat transmission, reliability of data reception is improved.

1	CRC CODE GENERATION	Polynomial; CRC-CCITT-16 $X^{16}+X^{12}+X^5+1$
2	DATA SCRAMBLING	Polynomial: $1+X^{-1}+X^{-15}$ Initial State: 6959 (Hex)
3	CONVOLUTION ENCODING	Convolution Coding ½ Rate, Constraint Length K=7 Polynomial: G1=133(Octal), G2=171(Octal)
4	HEADER DETAILS	CR: 192 Symbols (all '0's) BTR: 64 Symbols (all '1's) UW: 64 Symbols (07EA CDDA 4E2F 28C2 (Hex)) Note: UW transmitted with LSB first of every byte, starting from 07EA. (See Fig.1)
5	RF DATA ENCODING	Differential coding (NRZ-L) is done for the entire burst (Preamble and the convolution

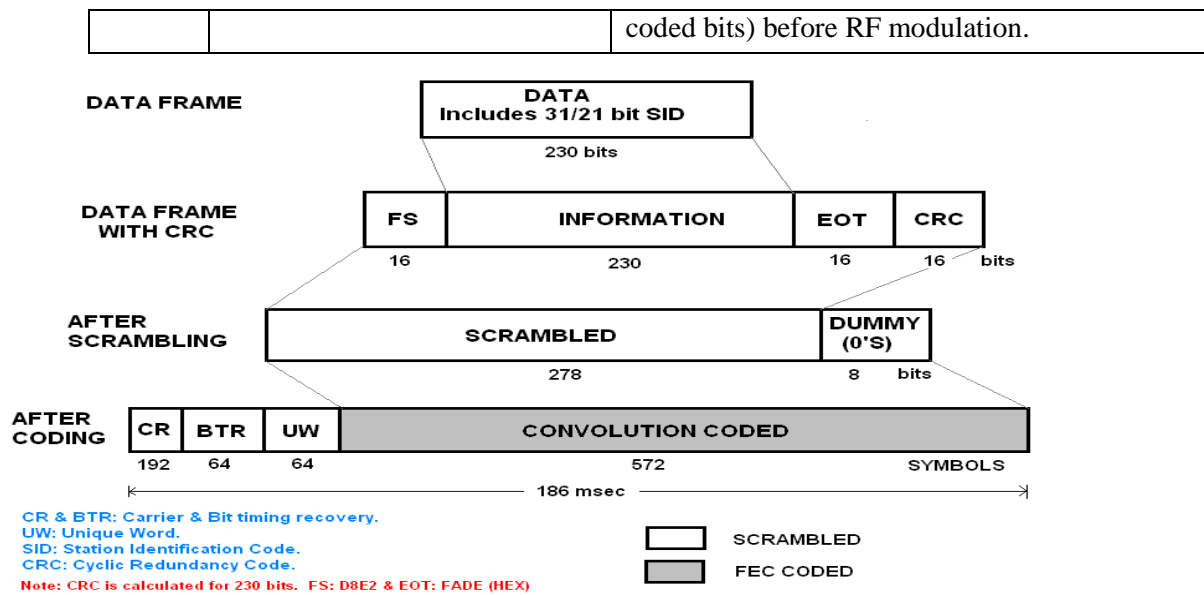

Fig. 1: Burst Transmission Format for TDMA Technique (4800 Symbols/sec.)

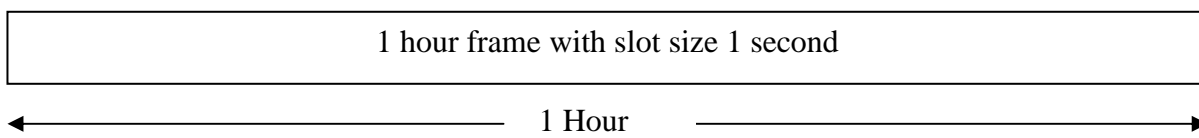

Fig. 2: TDMA Transmission Frame Format

Fig.1 may be referred to. CRC is calculated for 262 bits which include FS and EOT. It is then scrambled. 1byte, all '0's is added with the scrambled bits, after which the entire bits are convolution coded. Preamble (CR, BTR and UW) is appended with the convolution coded bits. The resulting bits are then differential coded and transmitted.

The system should have flexibility to accommodate more number of carrier channels by suitable changes in the TDMA transmission scheme.

More details will be provided at the time of the design review meeting which will be held with the successful bidder. However, it should be ensured by the bidder that the system configuration is flexible and accommodate all the proposed sensors without any additional cost.

9.3 INSAT DRT Specifications

For the purpose of data transfer from field AWLR/AWS/ARGunits to CWC Earth Receiving Station at Delhi/Burla/Jaipur the Data Relay Transponder (DRT) on the different INSAT / KALPANA-1 series of satellites shall be used and the specifications given below shall be treated as standard to be adhered by the offered telemetry system.

SATELLITE	KALPANA-1 74° E	INSAT-3A 83°E	INSAT-3D 82°E
RECEIVE FREQ. BAND	402.65 – 402.85Mhz	402.65 – 402.85Mhz	402.10 – 402.50Mhz
TRANSMIT FREQ. BAND	4500-4510Mhz band 4506.05Mhz	4500-4510Mhz band 4506.05Mhz	4500-4510Mhz band 4506.05Mhz
RECEIVE G/T	-19db/deg.K	-19db/deg.K	-19db/deg.K
MAX.EIRP	24dBW peak	24 dbW peak	24 dbW peak
C-BAND EIRP for RECEIVE FLUX DENSITY	2.0dBW for –146 dBW/m ²	2.0 dbW for –146 dbW/m ²	2.0 dbW for –146 dbW/m ²
REC.POLAR ISATION	RHCP	LHCP	LHCP
TRANSMIT POL	LINEAR	LINEAR	LINEAR
FREQ.TRAN SLATION ERROR	± 40Khz over life ± 6Khz over 1 month	± 40Khz over life ± 6Khz over 1 month	± 40Khz over life ± 6Khz over 1 month

Data Relay Transponder (DRT) onboard INSAT 3D will have a receiving frequency band of 402.3 MHz ± 200 KHz.

9.4 Channel Specifications for TDMA transmission format

Table below gives the present RTDAS parameters and their identification code used in the TDMA transmission format.

Sl.No.	Channel no.	Identification Code	Parameter
1	Cal1	C1:	Battery voltage (volts)
2	Cal2	C2:	Hourly rainfall
3	Cal3	C3:	Daily rainfall (rounded off to next higher integer). Reset at 08:00 IST
4	1	0000 (s00:)	Instantaneous sampled value of air temperature in deg C at the end of every full hour.
5	2.	1010 (s10:)	Snow Depth at end of every full hour
6	3	1011 (s11:)	Evaporation at end of every full hour

7	4	0100(s04:)	Wind speed (3-minute vector averaging prior to full hour).
8	5	0101(s05:)	Wind direction in degrees (3-minute vector averaging prior to full hour).
9	6	0110 (s06:)	Atmospheric pressure at end of every full hour
10	7	0111(s07:)	Instantaneous value of RH at the end of every full hour
11	8	1000 (s08:)	Water Level (Integer Part)
12	9	1001 (s09:)	Water Level (Decimal Part)
13	10	1110(s14:)	Duration of bright sunshine since last mid night. Reset to zero at mid night. (Global radiation will be transmitted in this slot instead of duration of sunshine.

9.5 GSM &GPRS Transmission format

Table below gives the GSM / GPRS data parameters and their identification code format which is required to transmit the data from datalogger to FTP server.

FORMAT:

&Station ID, Date and Time, MobileNumber,Battery,WaterLevel,HourlyRainfall,Daily Rainfall, AirTemperature,SnowDepth,Evaporation,Windspeed,Winddirection,Atmosphericpressure,Humidity, Sunshine Duration

Example Data Spring:

&738D1E76,07/01/18 10:00,9849556430,13.5,26.347,1.5,15.5,-11.4,--,187,1.2,256,936.7,56,125

Sl.No.	Channel no.	Parameter
1	Station ID	Start of String should be ‘&’ and Eight Characters Station ID provider by bidder
2	Date and Time	Measurement date and Time in DD/MM/YY HH:MM
3	Mobile Number	Mobile no of remote station SIM
4	Battery	Battery voltage at end of every full hour in Volts with 1 right digit
5	Water Level	Water level at end of every full hour in Mts. with 3 right digit
6	Hourly Rainfall	Hourly rainfall in mm. with 1 right digit
7	Daily rainfall	Daily rainfall (rounded off to next higher integer).in mm. with 1, right digit reset at 08:00 IST
8	Air Temperature	Instantaneous sampled value of air temperature in deg C with 1 right digit at the end of every full hour.

9	Snow Depth	Snow Depth at end of every full hour in Mts. with 3 right digit
10	Evaporation	Evaporation at end of every full hour in mm. with 0 right digit
11	Wind speed	Wind speed in knots with 1 right digit (3 minutes vector averaging prior to full hour).
12	Wind direction	Wind direction in degrees with 0 right digit (3 minutes vector averaging prior to full hour).
13	Atmospheric pressure	Atmospheric pressure at end of every full hour in hpa. with 1 right digit
14	Relative Humidity (RH)	Instantaneous value of RH at the end of every full hour in %. with 0 right digit
15	Solar Radiation / Sunshine Duration	Global Solar Radiation in W/m ² or sunshine Duration since last mid night. Reset to zero at mid night in number of minutes. (Global radiation will be transmitted in this slot instead of duration of sunshine)

Note:

1. If any sensor is not connected then it should transmit '--' characters in place of the sensor value.
2. Attached format is indicative, recommended for standardised data acquisition for development of unified Water Information System. In case bidder deviates from this format then bidder shall be responsible for integration of the data in E-SWIS without any manual intervention.

10.0 LIGHTNING PROTECTION

The entire unit has to be adequately protected against lightning and build of static charges. The lightning rod should protrude 1 m above the highest point (Antenna) and should be placed in the center of the pole. The mast should be electrically grounded by following as per CPWD earthing procedures. As a part of the maintenance, the lightning equipment shall be inspected on a yearly basis for its conductivity and effectiveness. Such inspection shall be carried out in the pre-monsoon period and any faults noticed shall be rectified.

11.0 EARTHING FOR EQUIPMENT

The electrical grounding for all other electronic and electrical equipment should be done by following standard CPWD procedure. The earthing for the equipment's should be done separately and should have a minimum distance of 2.5 meter from the earthing done for lightning rod. In no case both the earths should be done in the same earthing rod.

As a part of the maintenance, the earthing equipment shall be inspected on a yearly basis for its conductivity and effectiveness. Such inspection shall be carried out in the pre-monsoon period and any faults noticed shall be rectified.

12.SOLAR POWER SUPPLY WITH BATTERY BACKUP

12.1 Solar Power Supply

Solar Panel mounting hardware shall be designed to allow a great variety of attachment methods and accommodate a variety of mounting surfaces. They may be used to mount a module on a horizontal or vertical surface, on surfaces at angles between horizontal and vertical and on metal poles. Attachment methods include bolts, lag bolts, u – bolt brackets and stainless-steel hose clamps.

The Solar power supply shall be mounted on the roof of site buildings where existing. The Bidder shall supply a pole – mounted arrangement including a standard pole and necessary foundation and fixing arrangements.

The location of solar power installation shall be indicated by the concerned engineer – in – charge of each DCP.

In order to guard against frequent theft of solar panels the mounting device shall be so designed as to make the solar panel detachable as and when required. It is intended to store the solar panel during the night hours as well for longer durations in the non-monsoon period and the arrangement should be designed in such a way that the arrangement is sturdy and capable of handling frequent disconnecting and re connections.

The power supply shall primarily function through a set of sealed maintenance free rechargeable batteries capable of preventing deep discharge.

12.2 Batteries

The batteries required for the equipment above shall be maintenance free, rechargeable sealed batteries with the following features:

- Overcharge and deep discharge protection
- Leak-proof
- Easy handling – no special shipping container required
- Long service life
- Excellent recharge ability

One batterypack shall be provided for each DCP. The batteries pack provided shall have adequate capacity to sustain the maximum sized DCP configuration of sensors and telemetry equipment for a period of 15days of continuous operation at the frequency of one observation per hour per sensor and one transmission per hour on a 24-hourly basis. This capacity shall be available If it not, battery pack should be replaced with new one free of cost.

The necessary housing and configuration of the batteries shall be furnished in detail by the Bidder.

The battery pack shall also include arrangements of charging through a standard 220 V AC domestic power supply outlet and also from solar panels established as above. The normal supply to the DCP equipment shall be from battery pack only.

The Power Supply Unit shall have audio and/or visual alarms for overcharging and deep discharging conditions. The charge level shall also be indicated on the front panel of the pack.

The sealed construction shall allow trouble-free, safe operation in any position. The battery case shall be high-impact, with sufficient resistance to shock, vibration, chemicals and heat.

12.3 Solar Power supply for DCP

Solar panel offered should confirm the following technical specifications:

Feature	Units
Battery	
Voltage	From 0 to +60 V / as compatible with DCP and all sensors
Type	Sealed maintenance free
Capacity	Based on site conditions and telemetry method, power supply system shall provide 15 days of backup to all equipment's being powered up by the solar panel
Solar Panel	
Size	Based on site conditions and telemetry method, power supply system shall provide 15 days of backup to all equipment's being powered up by the solar panel
Mounts	The mounts should be sturdy in design and detachable but should not move or rotate with wind. It should have a provision to adjust direction and elevation during installation for optimal solar power generation
Charger	Smart solar charger with protection shall be provided by the bidder
General	
The supplier should determine optimal size of solar panels and batteries such that the system should be operational for atleast 15 days in absence of charging.	

12.4 Specification for Cabling and conduits.

- i. The term cable shall always include necessary type of connectors at both the ends for connecting between two equipment. The connectors shall be properly anchored with protective sheathing of the cable in such a way that the loads due to pulling and twisting shall be borne by the protective sheathing and the conductors shall not be subjected to any stress.
- ii. The connectors shall be so fixed on the individual components of the system

that the metal/plastic connector shall always transfer the loads due to pulling and twisting directly to the protective body of the component and the internal interface cards/ connections shall not be subjected to any load.

- iii. Laying of necessary data and power supply cables for connecting various components and embedding them or protecting them with necessary conduits shall be carried out as per directions of engineer-in-charge.
- iv. Wherever the cables are to be laid indoors and the length of the individual cable run exceeds 1 meter, the cable shall be housed in a protective conduit made of electrical supply grade conduit of appropriate diameter and the conduit shall be fixed with the wall at a height not less than 1 meter above the floor surface. Whenever the indoor cable is required to cross the floor, it shall be housed in a HDPE pipe of 25 mm internal diameter and the pipe shall be fixed to the floor with suitable protective covering to avoid tripping of personnel using the area or disturbance to the pipe due to such movement.
- v. Wherever cables are to run through open ground including the public road and pathways, the cable shall be armored/ shielded and shall be water ingress proof up to static water pressure of 5 kg/cm². All joints made in cable shall also meet the water proofing criteria. In addition, the cable shall be protected by housing the same in 25 mm HDPE pipe/flexible metallic conduit embedded at a depth of not less than 1.0 meter below the ground surface with a warning brick on the same. A sketch of the cable layout with respect to the identifiable marks of the area shall be prepared and handed over to the Engineer-in-charge for each such cable run on completion of the work of cable laying operation.
- vi. The joints in the cable connecting between the sensor and data collection unit shall be avoided by measuring the appropriate length of the cable required and attaching the same in one piece. If the cable joints become necessary, prior permission of the Engineer-in-charge shall be obtained before executing the same. The joint fabricated through a splicing and jointing kit shall be stronger than the parent cable.
- vii. The cable carrying data and electrical AC power shall be housed separately in different conduits separated by adequate distance to prevent leakage currents. The data cables shall also be laid out in such a way that the data integrity is not compromised due to mutual interference.
- viii. Shielded (screened) cables shall be used for external Cabling, the power and control cables shall be generally as per IS 8130/34. For these cables, equivalent IEC/IS specifications are also acceptable
 - All cables shall have stranded copper conductor of suitable cross section

depending on load.

- The Communication cable/power cable shall be of shielded, twisted pair type.

These are minimum requirements. Bidder is free to propose improved cabling technology

13. DATA PROCESSING HARDWARE AT DATA CENTRE

The purchaser will provide room at Data processing center equipped with requisite furniture etc. The purchaser will also provide a Local Area Network.

The data collected at site from various DCPs will be stored and transmitted **through INSAT telemetry** every hour to Earth Receiving Station (ERS) of CWC, New Delhi /Jaipur /Burla. Also the GPRS & GSM data shall be simultaneously transmitted by DCP and shall be received by GPRS & GSM receiving station at State Data center Bidhannagar. Thereafter, both data shall be transmitted through internet to e-SWIS software for further processing in the form of reports/bulletins. The decoded and/or raw data along with reports /bulletins shall be sent to State Data Centre Bidhanagar through Internet and e-SWIS cloud. The necessary automated arrangement is to be made by bidder.

The Bidder shall provide one high end server with monitor and with online 3KVA UPS with power backup of 4 hour and one computer node at the Data Center, Bidhannagar. The all the consumables (including batteries) except cartridge papers shall be responsibility of the Bidder during the entire period of warranty.

The minimum specification of server, computer node is as below:

Hardware at state data center shall be provided by bidder which will mainly comprise of following major item:

- a) Server with Monitor for reception of INSAT data transmitted through internet & GSM,GPRS data and Data storage of 8TB for 5 years
- b) Computer Node (Workstation) with monitorreport generation for operator
- c) Necessary data switch, router and fire wall for maximum 8 mbps internet speed
- d) 3KVA online UPS with 4 hours backup time
- e) A3 Size Color printer
- f) 55” LED display

13.1 Technical Specification:

The minimum specification of server, computer node are as below:

Data Center Computer Server		
No.	Item	Technical Specification
1	Form Factor	<ul style="list-style-type: none"> • Rack Mount Server
2	Processor	<ul style="list-style-type: none"> • Intel XEON or better (minimum 12 Core)
3	DIMM Memory	<ul style="list-style-type: none"> • Speed: 1600MT/s RDIMMS or better • 16 GB RDIMM, 1600MT/s, Low Volt, Dual Rank or similar
4	Hard Drive	<ul style="list-style-type: none"> • RAID 5 Software or Hardware Controller • 5 - 1TB 7.2K RPM Near-Line SAS 6Gbps 2.5in Hot-plug Hard Drive or similar
5	Network Adapter	<ul style="list-style-type: none"> • 1 Gb
6	Power Supply	<ul style="list-style-type: none"> • Dual, Hot-plug, Redundant Power Supply, 350W or similar
6	Electrical Supply	<ul style="list-style-type: none"> • 220V A/C
7	Devices	<ul style="list-style-type: none"> • Keyboard, • Mouse, • 22" monitor minimum
8	Software	<ul style="list-style-type: none"> • Windows Server 2012R2, latest MS office software & firewall system, with Good antivirus etc.
9	Accessories	<ul style="list-style-type: none"> • Power Cord • Rack Rail with cable management system • Power Points as needed • Computer Racks and related parts
10	Internet Connectivity	<ul style="list-style-type: none"> • Dual 1 Gbps Network port

13.2 Computer Node

Operating system	Windows 10 Home/Professional 64 bit
Chipset	Intel H270 and above or equivalent
Processor	Intel® Core™ i7-6700T with Intel® HD Graphics 530 (2.8 GHz, up to 3.6 GHz, 8 MB cache, 4 cores) and above or equivalent
Memory, standard	16GB DDR4 and above or equivalent (RAM)
Hard drive description	1 TB 7200 rpm SATA or above
Display	58.42 cm(23) diagonal WLED-backlit (1920 x 1080). Touch-enabled (optional)
Optical drive	DVD-Writer
Network interface	Integrated 10/100/1000 Gigabit Ethernet LAN
Wireless	802.11b/g/n (1x1) and Bluetooth® 4.0 combo (Optional)

Port	4 USB 2.0; 2 USB 3.0; 1 headphone/microphone combo
Pointing device	USB wired/wireless optical mouse
Keyboard	USB wired/wireless standard keyboard
Pre-installed software	Preinstalled MS Office Lifetime with Good antivirus is preferred.

13.3 Printers Specifications

A3 size color printer shall be procured for State Data Center shall be procured from a reputed manufacturer.

- i. A 3-color printer
- ii. Functions: Print, Copy, Scan
- iii. Printing Up to 20 page/minute
- iv. Black & color printing: As fast as 9.5 sec per page
- v. Recommended monthly page volume: 250 to 2000
- vi. Processor speed: 600MHz
- vii. Connectivity: e-Print capability
- viii. Paper handling input, standard: 100 sheet input tray
- ix. Paper handling output, standard: 100-sheet face-down bin

13.4 Display Unit (LED)

All display units shall be from reputed manufacturers

- i) Screen Type: 55'' Screen LED backlight type.
- ii) Display resolution: 1920 x 1080
- iii) Colors: 256K colors
- iv) Interfaces: 1 x Ethernet (RJ45) (max. 12Mbit/s) ,HDMI port,USB port 1 x USB Multimedia card / SD card slot combined.
- v) Industrial Ethernet: 1 x Ethernet (RJ45)
- vi) Protocols: Protocol (Ethernet) TCP/IP
- vii) image formats Supported: JPEG, JPS, MPO
- viii) Sound technology: Dolby digital

14. TRAINING AND DOCUMENTATION

The Bidder is required to provide an extensive training programme for the system. The training set forth in the following paragraphs is a minimum requirement and the bidder should propose any additional training that he considers critical for long term success of the system operations.

The Bidder is expected to provide an outline or table indicating the contents of each of the required courses. The table shall describe the specific topics to be covered for each day of the training period.

The Bidder is responsible for the salaries of the training instructors and all training materials. The costs of travel, transportation and per diem for the trainees shall be borne by the Purchaser.

Training shall be provided by the bidder in several phases. The training shall include both classroom and field trainings and will be continued during all five years. The bidder is required to have hydro-meteorological equipment specialists.

14.1 The Bidder shall provide trainings as training modules as part of the Tender given as under:

S. No.	Description	Numbers of training	Number of Participants per session
1	User Training Course for senior management. (one day)	3 (1 before/ during commissioning and 2 during warranty)	10-15
2	Operation and Maintenance course (3 days). Course topics will include sensor calibration, data logger configuration, data downloading, data retrieval, collection, Trouble shooting, processing, maintenance requirements, and procedures for equipment configuration, installation, site testing and commissioning.	5 (2 before /during commissioning and 3 during warranty period)	20-30

All aspects of the electrical, instrumentation and telemetry equipment being supplied shall be covered in the courses and full documentation shall be provided. The documentation and kits shall be got approved from purchaser in advance. The course shall provide detail documentation and shall ensure that the purchaser's personnel shall be able to modify settings/ parameters without reference back to the Supplier. The places / sites where this training will be held will be decided later by the purchaser.

The training course will take place as decided by the Purchaser. In case of formal training the Purchaser will provide classroom and other logistics. The Bidder will facilitate the professional and the training material. On-the-job training will be provided by the Bidder in conjunction with the installation of hydro-meteorological stations and during the course of maintenance as required.

14.2 TA/ DA of the trainees shall be borne by the purchaser.

14.3 Training kit containing course material in soft as well as hard copy shall be provided by the Bidder.

14.4 All logistical arrangement such as projector, training space etc. for training is to be made by purchaser.

15.0 PREVENTIVE MAINTENANCE

The bidder shall be responsible for operation and maintenance of all stations /components of installations, commissioning, site acceptance and operation tests. All equipment maintenance cost, repairs, replacements and repairs to civil work shall be borne by the bidder during the warranty Period. The scope of O&M support would include all materials and services including replacement of components including batteries, mandatory spare parts required to ensure smooth and sustainable operations of the entire system. The bidder shall provide monthly maintenance reports during the course of maintenance. The bidder shall supply a Manual specifying all the faults experienced by the system together with an account of how such faults have been rectified.

The bidders shall ensure the following minimum visits at remote site for preventive maintenance. The bidders should take time stamped geo tagged photographs of the equipment during each maintenance visit (either scheduled or unscheduled visit). The photographs should show the condition of equipment before maintenance, during maintenance and after maintenance.

15.1 SCHEDULE SHOWING FREQUENCY OF SCHEDULED VISITS FOR ROUTINE AND PREVENTIVE MAINTENANCE

Sl. No.	Station Category	Minimum Preventive Visits	Remarks
1	Maintenance of data Server & allied equipment's in Data center	4	Every Quarter and also on need basis
2	Maintenance of Automated rainfall station (ARS) , Evaporation- Pan and (AWLR) Automated water level recorder Stations	4	One pre-monsoon, two in monsoon period and one in post monsoon and also on need basis
3	Maintenance of Automatic Weather Stations (AWS) & Gate position sensor	4	One pre-monsoon, two in monsoon period and one in post monsoon and also on need basis

15.2 Operation & Maintenance

Bidder shall provide at least one dedicated Service Engineer cum operator at the State Data Center for Operation of RTDAS system and ensure seamless data transfer from remote stations to ERS at Delhi/Jaipur/Burla & then to State data Center via internet & e-SWIS software and also GSM/GPRS data transmission as per technical specifications.

The Service Engineer shall have experience of working on Hydro met stations/ Instrumentation / SCADA system for period of at least 3 years and shall be well versed with Operation and Maintenance aspects of RTDAS systems.

Operation and Maintenance shall include free of cost repairs/ replacement of hardware and Software necessary to keep the system functional for the period of five years (warranty) from Date of Installation.

TECHNICAL RESPONSIVENESS FORM

Bidder shall furnish clause by clause commentary against the laid down technical specification and standards as per the format given below:

(A) Summary of Instructions

- (i) Particulars of Manufacturer and local agent cum representative are to be given under rows Model and Address.
- (ii) **All entry boxes in column “Specification and Standards as offered in by Bidder” shall be filled-in accurately and comprehensively. Quantitative fields shall be filled in accurately. It is not acceptable to use ‘Yes’, No, Compliant or similar evading words. Following format is designed to help the Bidder to understand the requirements of the equipment being procured. The Bidder must describe in the format how his bid responds to the technical requirements of the equipment. Bidder to note that one or two-word responses (e.g. “Yes”, “No” “will comply” or similar evading words) are normally not sufficient to confirm the responsiveness with the technical requirements, hence elaborate responses are sought from the bidders. In case deviation on the following technical requirements of equipment is not as per the minimum criteria mentioned, the bids may be declared “non-responsive”**
- (iii) Requested materials and information shall be enclosed with the bid and be unambiguously associated with instruments as offered in the bid
- (iv) Negligence to comply with the instructions and requirements as stated above makes the bid liable to be rejected.
- (v) Abbreviations: OD-Outer Diameter; ID-Inner Diameter; FS-Full Scale; Pa-Pascal (unit of pressure), RTDAS-Real time data acquisition system; DRS-Data Retrieval System, DCP- Data collection Platform, AWS- Automatic Weather Station, ARG- Automatic Rain Gauge, AWLR- Automatic Water Level Recorder.
- (vi) Sample interval is the interval at which samples or sensor readings are taken. The recording /measurement interval defines the interval at which the data records are stored in memory. A data record can represent a single sample or the average of a number of samples. In particular the result of the wave suppression filter is a single record representing the average value of a number of samples.

B) Entries requiring special attention:

- 1) The proposed maintenance interval and the recommended spares as offered in the bid shall be based on instrument deployment history. The training proposal shall be based on experience in similar cases. Moreover, it shall consider the educational level and specialization of the trainees.

C) Bidder shall provide information in the formats given below:

i) Make/ Model/ Local Agent etc.:

Bidder	AWLR make/ model	ARG make/model	AWS make/Model	Data Logger make/ model	Shaft encoder type Gate sensor make/model	Data Server make / Model
Name / Complete Address/Website/Email	Model: Manufacturer: Authorization: Name: Place: Tel: Fax: E-mail: Web:	Model: Manufacturer: Authorization: Name: Place: Tel: Fax: E-mail: Web:	Model: Manufacturer: Authorization: Name: Place: Tel: Fax: E-mail: Web:	Model: Manufacturer: Authorization: Name: Place: Tel: Fax: E-mail: Web:	Model: Manufacturer: Name: Place: Tel: Fax: E-mail: Web:	Model: Name: Address: Tel: Fax: E-mail: Web:

ii) B Clause by Clause Commentary against laid down technical specifications:

1) Specifications of the RADAR Water Level Transmitter

Name of Goods-Its Features	Required Specifications and standards as per bidding document	Specification and standard as offered in by Bidder	Remarks
RADAR Level Sensor		Make: Model: Manufacturer Name, address, email, phone, website, fax	
Site Conditions			
Ambient Temperature	From -5 to +60 Degree Celsius		
Humidity	0 to 100 %		
Altitude	0 to 2500 meter		
Sensor			
Sensor Type	Microwave non-contact sensor		
Range	35meters		
Resolution	3 mm or better		
Accuracy	0.02 % FSO		
Output	SDI-12 / RS-485 / 4-20mA		

Interface			
Power Supply	To be powered by Solar Panel provided by bidder.		
Beam angle	Less than 16 degrees.		
General Features			
Material	Corrosion Resistance (Stainless steel / Aluminum PVC/ UV stabilized ABS with metal casing)		
Enclosure	The Sensor shall be easy to dismount and replace in the event of malfunction.		
Tools	Complete tool kit for operation and routine maintenance		
Manuals	Full Documentation and maintenance manual in English		
Accessories	Sensor Mounting support, cables and other accessories as required		
Protection	NEMA 4 or IP67 or better		
Horizontal Mounting/Installation Arrangements	Above FRL, Below a bridge girder wherever available otherwise horizontal cantilever arrangement from a mast/wall/pedestal to be provided		
Special Feature	Radar Sensor should have inbuilt diagnostic & averaging feature		

2) Automated weather station (AWS)sensors

Name of Goods-Its Features	Required Specifications and standards as per bidding document	Specification and standard as offered in by Bidder	Remarks
Site Conditions			
Ambient Temperature	From -5to +60°C		
Humidity	5 to 100 %		
Altitude	0 to 2500 meter		
Air Temperature and Relative Humidity Sensor		Make: Model: Manufacturer Name, address, email, phone, website, fax	
Air Temperature Sensor			

Sensor Type	Platinum resistance or better or equivalent		
Range	-5 to 60 Degree Celsius		
Resolution	0.1°C		
Accuracy	Within $\pm 0.2^\circ\text{C}$ in the entire working range		
Response Time	10 sec or lesser		
Relative Humidity Sensor			
Sensor Type	Capacitive/ Solid State Humidity Sensor		
Range	0 to 100 %		
Resolution	1%		
Accuracy	$\pm 3\%$ or better		
Response time	10 secs or lesser		
General			
Self-aspirated	To ensure continuous supply of air. Free from turbulence, water droplets and radiation		
Power Supply	To be powered by solar power provided by bidder.		
Accessories	All accessories for mounting the instrument at ~1.5mts height above the ground level e.g. special cross arm clamps or flag, if any shall be provided		
Output Interface	SDI-12/ RS-485/ Analog		
Wind Speed and Direction Sensor		Make:	
		Model:	
		Manufacturer Name, address, email, phone, website, fax	
Sensor Type	Ultrasonic sensor (No moving Parts)		
Range	0-60 m/s for speed and 0-360 degrees for direction or better		
Resolution	0.1m/s for Speed; ± 1 degree for Direction		
Accuracy	Wind speed $\pm 2\% \pm 0.1\text{m/s}$ (up to 20 m/s) and $\pm 3\%$ (for 20 to 60 m/s) Wind direction- $\pm 1^\circ$ or better		

Response time	Less than 1 second lag in operating range		
Mounting	All accessories for mounting the instrument at 10mts height above the ground level, e.g. special cross arm clamps or flag if any shall be provided.		
Output Interface	SDI-12 / RS-232/ RS-485		
Air Pressure Sensor		Make: Model: Manufacturer Name, address, email, phone, website, fax	
Sensor Type	Temperature Compensated		
Range	600 to 1100 hPa		
Resolution	± 0.1 hPa		
Accuracy	±0.2hPa		
Power Supply	To be powered by solar power provided by bidder		
Output Interface	SDI-12 / RS-232/ RS-485		
Solar Radiation Sensor		Make: Model: Manufacturer Name, address, email, phone, website, fax	
Sensor Type	Silicon Pyranometer		
Threshold	120 W/m2 of direct solar irradiance		
Methodology	Alternate shading of sensor to account for sky radiation or Sunshine duration shall be computed in datalogger		
Spectral Range	400nm to 1100 nm		
Range	0-2000 W/Square meter		
Resolution	1 W/Square meter		
Accuracy (Including Temperature Compensation)	3% or better		
General Features			
Material	Corrosion Resistance Metal (Stainless steel / Aluminum)		

Tools	Complete tool kit for operation and routine maintenance		
Manuals	Full Documentation and maintenance manual in English		
Accessories	All accessories for mounting the instrument at ~1.5mts height above the ground level e.g. special cross arm clamps or flag, if any, shall be provided.		
Output Interface	SDI-12/RS-485/ 4-20 mA/Analog		
Evaporation- Pan specification		Make:	
		Model:	
		Manufacturer Name, address, email, phone, website, fax	
Operating temperature	-5 to +60 degrees Celsius		
Humidity	5 to 100 %		
Sensor Type	Shaft Encoder / ultrasound radar / Float & pulley type As Specified by IS:5973 which known as the modified Class A Pan potentiometer		
Diameter of the pan	1.2 m or more		
Accuracy	± 1% FSO		
Resolution	1mm		
Power Supply	To be powered by solar power provided by bidder		
Accessories	As required for complete installation of the sensors and equipment		
Material	The pan is made of Copper or stainless steel sheet, tinned inside and painted white outside		
Covering	The top of the pan is covered with a hexagonal wire net of GI to protect water in the pan from birds		
Platform	Rot resistance, timber treated with creosote or other effective Wood preservative		
Measurement range	150 mm		
Output Interface	SDI-12 / RS-485 / 4-20 mA /		

	Analog		
3. Automated Rain Gauge			
Name of Goods- Its Features	Required Specifications and standards as per bidding document	Specification and standard as offered in by Bidder	Remarks
Automated Rain Gauge		Make: Model: Manufacturer Name, address, email, phone, website, fax	
Site Conditions			
Ambient Temperature	From -5to +60 Degree C		
Humidity	5 to 100 %		
Altitude	0 to 2500 meter		
Sensor			
Sensor Type	Tipping Bucket type with reed switch		
Range	250 mm/h or better		
Resolution	0.5 mm or better		
Accuracy	2% or better, ± 2 mm		
General Features			
Output Interface	SDI12/ RS-485 / 4-20 mA/Switch closure output		
Power Supply	To be powered by solar power provided by bidder		
Material	Corrosion Resistance Metal (Stainless steel/ Aluminum)		
Enclosure	NEMA 4 or IP65		
Tools	Complete tool kit for operation and routine maintenance		
Manuals	Full Documentation and maintenance manual in English		
Accessories	Sensor Mounting support, cables and other accessories as required		
Protection	Bidder shall provide spout filter and bird cage to prevent ingress of insects and debris and with Bubble Spirit Level and adjustable legs for horizontal alignment of tipping		

	bucket mechanism		
Certification	IMD/ WMO certification shall be provided.		

4.Specifications of Shaft Encoder type Gate Position Sensors(Shaft Encoder Type)

Name of Goods- Its Features	Required Specifications and standards as per bidding document	Specification and standard as offered in by Bidder	Remarks
Gate Position Sensors(Shaft Encoder Type)		Make: Model: Manufacturer Name, address, email, phone, website, fax	
Site Conditions			
Ambient Temperature	From -5 °C to +60°C		
Humidity	5 to 100 %		
Altitude	0 to 2500 meters		
Sensor			
Sensor Type	Shaft Encoder based rotaryoptical/magnetic Absolute encoderposition sensor		
Range	1-20 meters		
Resolution	3mm or less		
Accuracy	0.025 % FSO		
Output Interface	SDI-12 / RS-485 / 4-20 mA		
Hardware/ Ports/accessories	Communication ports compatible with data logger,		
General Features			
Power Supply	To be powered by Solar power system provided by bidder		
Material	Corrosion Resistance Metal (Stainless steel or Aluminium)		
Enclosure	Outdoor environment with corrosion resistant material		

	Lockable (key) box provided by the supplier to be mounted on Gate /, with IP65 or better		
Tools	Complete tool kit for operation and routine maintenance		
Manuals	Full Documentation and maintenance manual in English		
Mounting	Wiring from sensor to Datalogger must be through HDPE/ GI Pipe Conducting and flexible metallic conduiting wherever applicable, Sensor mounting support/clamps, limit switches & cabling etc.		
Process connections	through suitable coupling		
Manufacturer's Calibration Certificate	Required		

5. Specifications of Data Logger with 8 AI channels

Name of Goods- Its Features	Required Specifications and standards as per bidding document	Specification and standard as offered in by Bidder	Remarks
Data Logger with 8 AI channels		Make: Model: Manufacturer Name, address, email, phone, website, fax	
Site Conditions			
Ambient Temperature	From -5 to +60 Degree C		
Humidity	5 to 100 %		

Altitude	0 to 2500meter		
Sensor Interface			
Analogue Inputs	8-Analogue Input Channels 4 to 20 mA, 100% over range withstand (Analog input channels are required in datalogger, if any sensor offered by bidder requires Analog interface to integration with datalogger)		
SDI Port	One SDI-12 Interface port		
Serial Port for sensor interface	One RS-232 for sensor Interface One RS-485 for sensor Interface port		
Pulse Input	1 Input for Rain Gauge impulse		
Input - Output Interfaces			
Data Transfer	USB stick option for Data transfer		
Port for Configuration	One Serial Port (RS-232/USB) for communication with Laptop for programming		
Port for Telemetry	2 Ports for Communication with Telemetry (GSM,GPRS and INSAT) device Both telemetry systems should work simultaneously for redundancy		
Display Port	Port for connecting external display screen for data in running text		
Computer Software			
Operating System	Windows software for system configuration / communication		
Version	English language version		
Licenses	All required licenses shall be included		
Analog to Digital Converter			
Resolution	16 bit or better		
Conversion Accuracy	± 1 LSB		
Sample intervals	1 Sec to 24 hours (user scalable)		
General Features			

Flash memory	Non-volatile Flash memory that can store one year of data and expandable upto minimum 1GB via. USB/SD card		
Resolution	A/D resolution ≥ 16 bit		
Recording Interval	Individual recording intervals for each sensor/parameter		
Firmware Operating System	Multi-tasking operating system - must log data and transmit at same time		
Display	Inbuilt Digital Display for viewing current data and setting values		
Power Supply	Shall be powered by solar Power supply to be provided by bidder with DCP, low current drain (quiescent $\leq 10.0\text{mA}$)		
Battery Voltage	Monitoring of battery voltage level		
Internal battery	Internal battery backup for clock, lithium battery, storage 2 years		
Charge Controller	Internal or External		
User Permissions	Different user levels, system of user rights / passwords, access restricted to unauthorized personnel		
Internal clock	Internal clock with drift less than 1 second per Week		
Keypad	For displaying or transferring data to memory stick, configuration of data logger and sensors		
Real time clock	GPS synchronized & timing is required in IST format		
System integrity	System integrity check procedures		
Enclosure	for wall-mounting in a shelter / enclosure with IP65 (NEMA 4 or equivalent) protection or better		
Accessories	Serial cable + adaptor (if required for Notebook connection). All accessories (fixing units, etc.) as required		
Tools	complete tool kit for installation and routine maintenance giving full detail (number of pieces and type)		

Manuals	full documentation and maintenance instructions in English (1 copy per station).		
<u>GSM /GPRS MODEM</u>		Make: Model: Manufacturer Name, address, email, phone, website, fax	
Operating Temperature	From -5 to +60 °C		
Transmission System	GPRS/edge-based data transmission system		
Performance	Data Reception availability of 95% or better		
Form factor	The GSM /GPRS modem should either be integral part of data logger specified above, or it should be supplied as independent unit compatible with supplied data logger		
Specific Features			
Communication Direction	Utilize GPRS network for two-way connection with FTP,TCP/IP (INTERNET) connection and SMS		
Transmission trigger	Data collection to be triggered by interrogation from Data Center, or by event-based transmission triggered by remote site		
Power Saving	Ability to disable interrogation system in order to save power at remote site		
Communication Protocol	Data transmission to execute HTTP Post, FTP, SMS to transmit and receiving data to the Data Center		
Accessories	All associated equipment, including Antenna all cables and mounting hardware		
Antenna features			
Frequency range	900 MHz:	824-960	

	MHz/1800MHz:1710-1880 MHz, 4G and better		
Impedance	50 ohms		
VSWR	≤ 2.0		
Radiation	Omni-directional		
Operating temperature	-5 to + 60 degrees Celsius		
Connector	SMA or suitable RF connector adaptable to GSM/GPRS modem		
Cable length	As required at site		

6.Specifications of Data Logger with 2 AI Channel

Name of Goods- Its Features	Required Specifications and standards as per bidding document	Specification and standard as offered in by Bidder	Remarks
Data Logger with 2AI sensors		Make: Model: Manufacturer Name, address, email, phone, website, fax	
Site Conditions			
Ambient Temperature	From -5to +60 Degree C		
Humidity	5 to 100 %		
Altitude	0 to 2500meter		
Sensor Interface			
Analogue Inputs	2-Analogue Input Channels 4 to 20 mA, 100% over range withstand (Analog input channels are required in datalogger,if any sensor offered bybidder requires Analoginterface to integration with datalogger)		
SDI Port	One SDI-12 Interface port		
Serial Port for sensor interface	One RS-232 / RS-485 for sensor Interface port		
Pulse Input	1 Input for Rain Gauge impulse		

Input - Output Interfaces			
Data Transfer	USB stick option for Data transfer		
Port for Configuration	One Serial Port (RS-232 /USB) for communication with Laptop for programming		
Port for Telemetry	2 Ports for Communication with Telemetry (GSM,GPRS and INSAT) device Both telemetry systems should work simultaneously for redundancy		
Display Port	Port for connecting external display screen for data in running text		
Computer Software			
Operating System	Windows software for system configuration / communication		
Version	English language version		
Licenses	All required licenses shall be included		
Analog to Digital Converter			
Resolution	16 bit or better		
Conversion Accuracy	± 1 LSB		
Sample intervals	1 Sec to 24 hours (user scalable)		
General Features			
Flash memory	Non-volatile Flash memory that can store one year of data and expandable upto minimum of 1 GB via. USB/SD card		

Resolution A/D resolution ≥ 16 bit

Recording Interval	Individual recording intervals for each sensor/parameter		
Firmware Operating System	Multi-tasking operating system - must log data and transmit at same time		
Display	Inbuilt Digital Display for viewing current data and setting values		
Power Supply	Shall be powered by solar Power supply to be provided by bidder with DCP,low current drain (quiescent ≤ 10.0 mA)		
Battery Voltage	Monitoring of battery voltage level		

Internal battery	Internal battery backup for clock, lithium battery, storage 2 years		
Charge Controller	Internal or External		
User Permissions	Different user levels, system of user rights / passwords, access restricted to unauthorized personnel		
Internal clock	Internal clock with drift less than 1 second per Week		
Keypad	For displaying or transferring data to memory stick, configuration of data logger and sensors		
Real time clock	GPS synchronized & timing is required in IST format		
System integrity	System integrity check procedures		
Enclosure	for wall-mounting in a shelter / enclosure with IP65 (NEMA 4 or equivalent) protection or better		
Accessories	Serial cable + adaptor (if required for Notebook connection). All accessories (fixing units, etc.) as required		
Tools	complete tool kit for installation and routine maintenance giving full detail (number of pieces and type)		
Manuals	full documentation and maintenance instructions in English (1 copy per station).		
<u>GSM /GPRS MODEM</u>		Make:	
		Model:	
		Manufacturer Name, address, email, phone, website, fax	
Operating Temperature	From -5 to +60 °C		
Transmission System	GPRS/edge-based data transmission system		
Performance	Data Reception availability of 95% or better		
Form factor	The GSM /GPRS modem should either be integral part of data logger specified above, or it should be supplied as independent unit		

	compatible with supplied data logger		
Specific Features			
Communication Direction	Utilize GPRS network for two-way connection with FTP, TCP/IP (INTERNET) connection and SMS		
Transmission trigger	Data collection to be triggered by interrogation from Data Center, or by event-based transmission triggered by remote site		
Power Saving	Ability to disable interrogation system in order to save power at remote site		
Communication Protocol	Data transmission to execute HTTP Post, FTP, SMS to transmit and receiving data to the Data Center		
Accessories	All associated equipment, including Antenna all cables and mounting hardware		
Antenna features			
Frequency range	900 MHz: 824-960 MHz/1800MHz:1710-1880 MHz, 4G and better		
Impedance	50 ohms		
VSWR	≤ 2.0		
Radiation	Omni-directional		
Operating temperature	-5 to +60 degrees Celsius		
Connector	SMA or suitable RF connector adaptable to GSM/GPRS modem		
Cable length	As required at site		

7 Specifications of LED Running Text Display Unit

Name of Goods-Its Features	Required Specifications and standards as per bidding document	Specification and standard as offered in by Bidder	Remarks
LED Running Text Display Unit		Make: Model: Manufacturer Name, address, email, phone,	

		website, fax	
Site Conditions			
Ambient Temperature	From -5 to +60 °C		
Humidity	5 to 100 %		
Altitude	0 to 2500 meter		
G			
Size	4' (W) X 7" (H) or better		
Pixel Pitch	8 mm or narrower		
Maximum brightness	2000 cd/m2 meter		
Colour	Red / Amber		
Viewing Distance	≥10m		
Optimum View Angle	Horizontal 120°; Vertical 60°		
Ingression proof	IP 65 or better		
Text Lines	One Line display		
Refresh rate	300 to 2000 hertz		
Input Voltage	220 ± 20 Volt AC		
LED life	50,000 hours or better		
Communication Port	Digital port RS-485 or RS-232 (user settable) Display unit should be interface with display port of RTDAS datalogger to display the Hydro-Meteorological Data string in running text with user selectable speed.		
Programming	Configuration Through software to		

	be part of supply		
--	-------------------	--	--

Specifications of INSAT Radio

Name of Goods- Its Features	Required Specifications and standards as per bidding document	Specification and standard as offered in by Bidder	Remarks
INSAT Transmitter Radio		Make: Model: Manufacturer Name, address, email, phone, website, fax	
Operating Temperature	From -5to +60°C		
Environment Relative Humidity	0 to 100 %		
Career Frequency	402 – 403 MHz		
Carrier Settability	In steps of 100Hz from 402.0 MHz to 403.0 MHz		
Modulator	PCM/BPSK		
Data coding	NRZ (L)		
Output Power	3-10Watt, user settable		
Data Bit Rate	4.8 kbps		
Frequency Stability			
a) Long Term drift	Transmit frequency inaccuracy including aging of oscillator should not exceed ± 400 Hz per year. Oscillators/synthesizer should have provision to adjust for the long-term drift.		
for temperature	± 1 ppm or better (-40 to +55 degree Celsius)		
Signal Bandwidth	6.0 KHz maximum or better		
Power Stability	± 1 dB		
Spurious	-60dB or better		
Harmonics	-40dB or better		
Antenna cable	LMR 400 grade or better		
Performance	Data Reception availability of 99% or better		
Form factor	The Transmitter should either be integral part of data logger		

	specified above, or it should be supplied as independent unit compatible with supplied data logger		
Operating Power	Switched 12V DC controlled by data logger		
Yagi Antenna		Make: Model: Manufacturer Name, address, email, phone, website, fax	
Polarization	LHCP or RHCP, switchable in field		
Gain	Minimum 11 dBi or better		
Center Frequency	402-403 MHz		
3dB Beam width	40°		
VSWR	1.2 : 1		
Impedance	50 ohms		
Axial Ratio	To be specified by tenderer		
Operating temperature	-5°C to +60°C		
Operating Relative Humidity	0 to 100% RH		
Size	Small, portable		
Operating rain rate	100 mm/hr and water proof		
Mounting	Proper mounting and Pointing arrangement for 360-degree azimuth and elevation adjustment		
Operating Wind speed	250 kmph		
Wind Survival	300 kmph		
Material	Rust-proof and Oxidation-proof		
Specific Features			
Satellite System	INSAT Radio System to be Used on the INSAT Satellite operated by ISRO		
Certification	Certificate of acceptance required by ISRO and / or IMD as part of the bid package		

Accessories	All associated equipment, including GPS, GPS Antenna, INSAT Antenna, all cables and mounting hardware		
TDMA Transmission Format	As specified in the table for channel specifications for TDMA transmission format		
GPRS / GSM transmission format	As specified in the table for GSM /GPRS communication format		

8. Specifications of Solar Power Supply System

Name of Goods-Its Features	Required Specifications and standards as per bidding document	Specification and standard as offered in by Bidder	Remarks
Battery		Make: Model: Manufacturer Name, address, email, phone, website, fax	
Voltage	From 0 to +60 V / as compatible with DCP and all sensors		
Type	Sealed maintenance free		
Capacity	Based on site conditions and telemetry method, power supply system shall provide 15 days of backup to all equipment's being powered up by the solar panel		
Solar Panel		Make: Model: Manufacturer Name, address, email, phone, website, fax	
Size	Based on site conditions and telemetry method, power supply system shall provide 15 days of backup to all equipment's being powered up by the solar panel		

Mounts	The mounts should sturdy in design and be detachable but should not move or rotate with wind. It should have a provision to adjust direction and elevation during installation for optimal solar power generation		
Charger	Smart solar charger with protection shall be provided by the bidder		

9. Specifications of Data Server

Name of Goods-Its Features	Required Specifications and standards as per bidding document	Specification and standard as offered in by Bidder	Remarks
Data Server with Monitor		Make: Model: Manufacturer Name, address, email, phone, website, fax	
Form Factor	Rack Mount Server		
Processor	Intel XEON or better (minimum 12 Core)		
DIMM Memory	<ul style="list-style-type: none"> Speed: 1600MT/s RDIMMS or better 16 GB RDIMM, 1600MT/s, Low Volt, Dual Rank or similar 		
Hard Drive	<ul style="list-style-type: none"> RAID 5 Software or Hardware Controller5 - 1TB 7.2K RPM Near-Line SAS 6Gbps 2.5in Hot-plug Hard Drive or similar 		
Optical drive	<ul style="list-style-type: none"> DVD-Writer 		
Network Adapter	1 Gb		
Power Supply	Dual, Hot-plug, Redundant Power Supply, 350W or similar		
Electrical Supply	220V A/C		
Devices	<ul style="list-style-type: none"> Keyboard, Mouse, 22" monitor minimum 		
Software	Windows Server 2012R2, latest MS office software & firewall system, with Good antivirus etc.		

Accessories	<ul style="list-style-type: none"> • Power Cord • Rack Rail with cable management system • Power Points as needed Computer Racks and related parts		
Internet Connectivity	Dual 1 Gbps Network port		

10. Specification of Computer Node(Workstation)

Name of Goods-Its Features	Required Specifications and standards as per bidding document	Specification and standard as offered in by Bidder	Remarks
Computer Node with Monitor(Separate Make and model name for each require)		Make: Model: Manufacturer Name, address, email, phone, website, fax	
Operating system	Windows 10 Home/Professional 64 bit		
Chipset	Intel H270 and above or equivalent		
Processor	Intel® Core™ i7-6700T with Intel® HD Graphics 530 (2.8 GHz, up to 3.6 GHz, 8 MB cache, 4 cores) and above or equivalent		
Memory, standard	16GB DDR4and above or equivalent (RAM)		
Hard drive description	1 TB 7200 rpm SATA and above		
Display	58.42 cm(23) diagonal WLED-backlit (1920 x 1080). Touch-enabled (optional)		
Optical drive	DVD-Writer		
Network interface	Integrated 10/100/1000 Gigabit Ethernet LAN		
Wireless	802.11b/g/n (1x1) and Bluetooth® 4.0 combo (Optional)		
Port	4 USB 2.0; 2 USB 3.0; 1 headphone/microphone combo		
Pointing device	USB wired/wireless optical mouse		
Keyboard	USB wired/wireless standard keyboard		

Pre-installed software	Preinstalled MS Office Lifetime with Good antivirus is preferred.		
------------------------	---	--	--

11. Specifications of A3 Size Color printer

Required Specification and Standards as per Bidding Document	Specification and Standards as offered in by Bidder	Remarks
A3 Size Color printer	Make: Model: Manufacturer Name, address, email, phone, website, fax	
Functions: Print, Copy, Scan		
Printing Up to 20 page/minute		
Black & color printing: As fast as 9.5 sec per page		
Tonner capacity : Up to 8000 pages printing		
Recommended monthly page volume: 250 to 2000		
Processor speed: 600MHz		
Connectivity: e-Print capability		
Paper handling input, standard: 100 sheet input trays		
Paper handling output, standard: 100-sheet face-down bin		

13 .Specifications of Industrial Grade Display Unit (LED)

Required Specification and Standards as per Bidding Document	Specification and Standards as offered in by Bidder	Remarks
55'' Display Unit (LED)	Make: Model: Manufacturer Name, address, email, phone, website, fax	
Screen Type: 55'' Screen LED backlight type		
Display resolution: 1920 x 1080		
Colors: 256K colors		
Interfaces: 1 x Ethernet (RJ45) (max. 12Mbit/s), HDMI port, USB port 1 x USB Multimedia card / SD card slot combined		
Industrial Ethernet: 1 x Ethernet (RJ45)		

Protocols: Protocol (Ethernet) TCP/IP		
image formats Supported: JPEG, JPS, MPO		
Sound technology: Dolby digital		

Drawings

List of Drawings		
Drawing No.	Name	Purpose
1	Location of Proposed Rain Gauge Stations	Index Map
2	Location of Proposed River Gauge Stations	Index Map
3	Location of Major Reservoirs	Index Map
4	Typical Fencing Enclosure for ARG/AWS	Security Arrangement
5	Typical AWLR Support for River Bank	Installation Arrangement
6	Typical Solar Panel Support and AWLR Radar Support on Bridge	Installation Arrangement

Fig 2: Location of Proposed River Gauge Stations

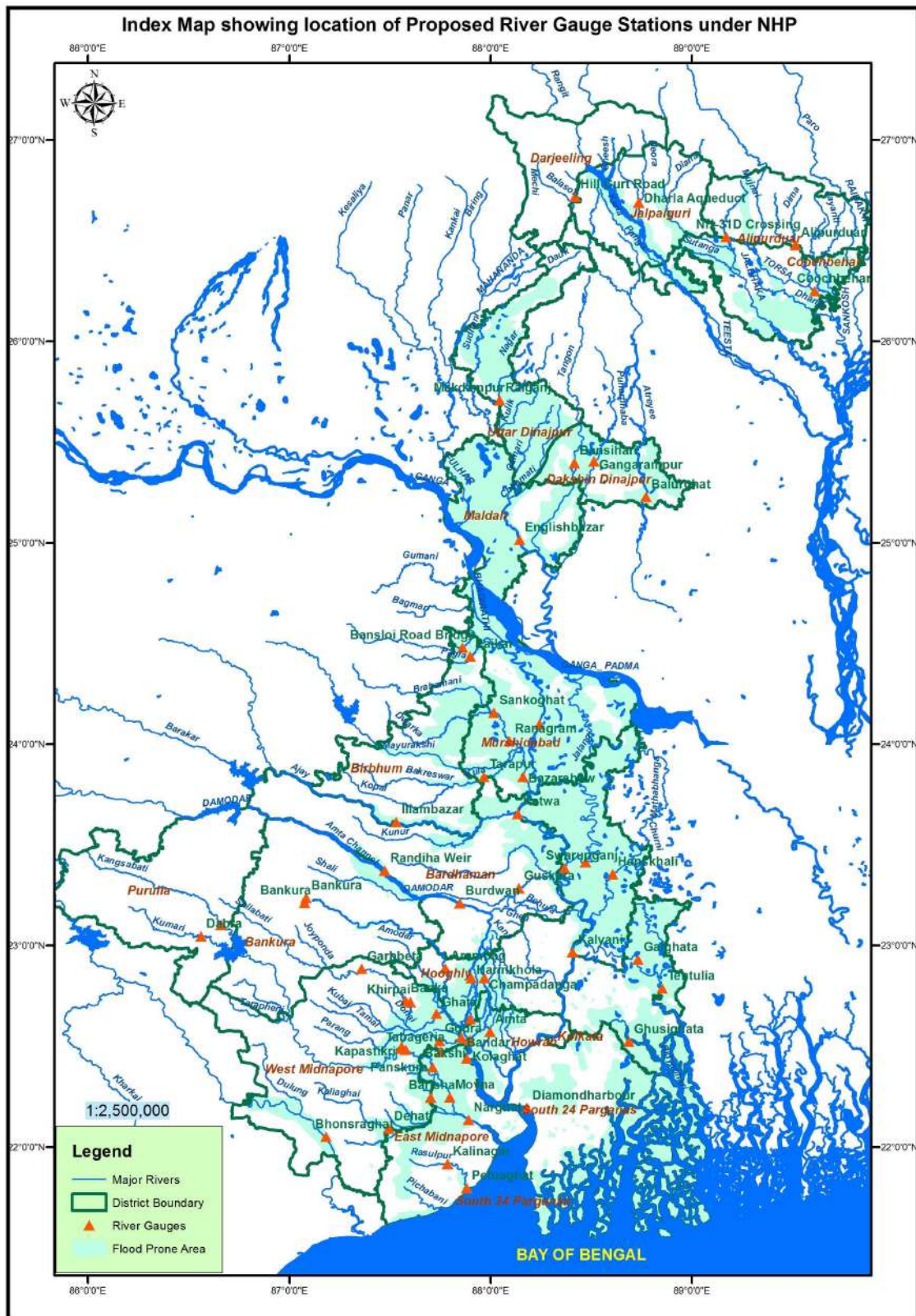
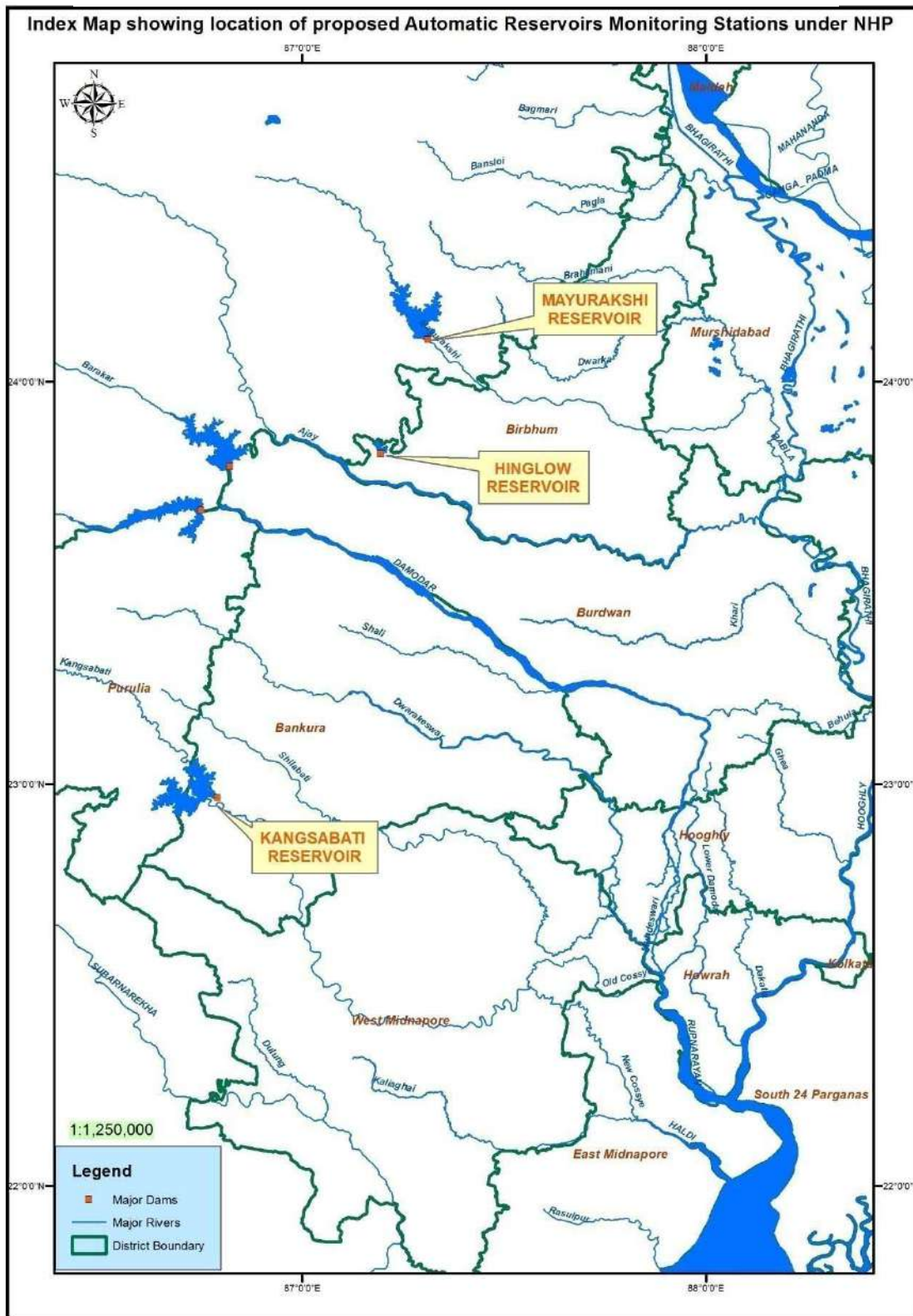

Fig 3: Location of Major Reservoirs



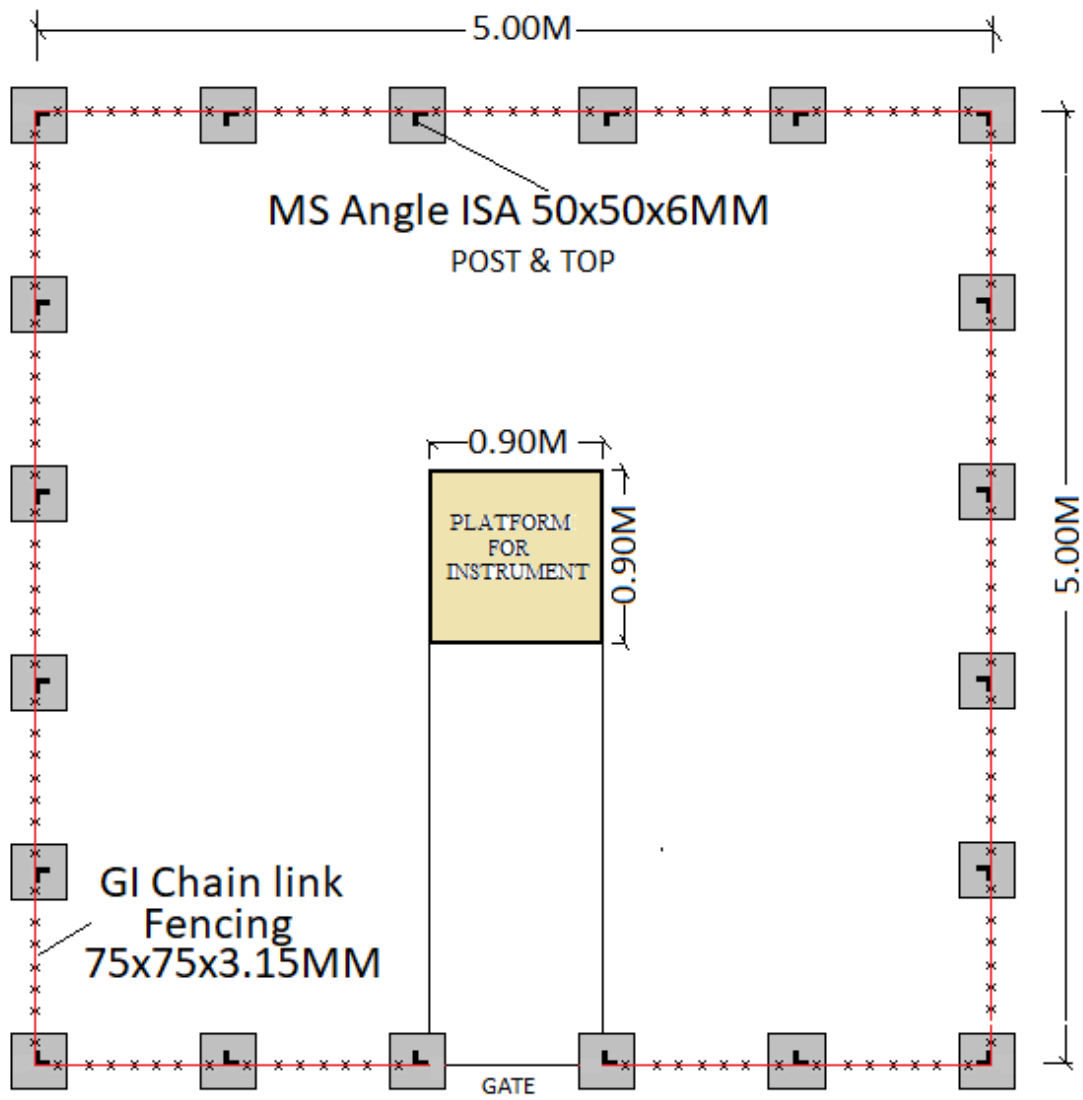

Fig 4: Typical Fencing Enclosure for ARG/AWS

(SIZE 5.00Mx5.00Mx1.00M)

Fig 5: Typical AWLR Support for River Bank

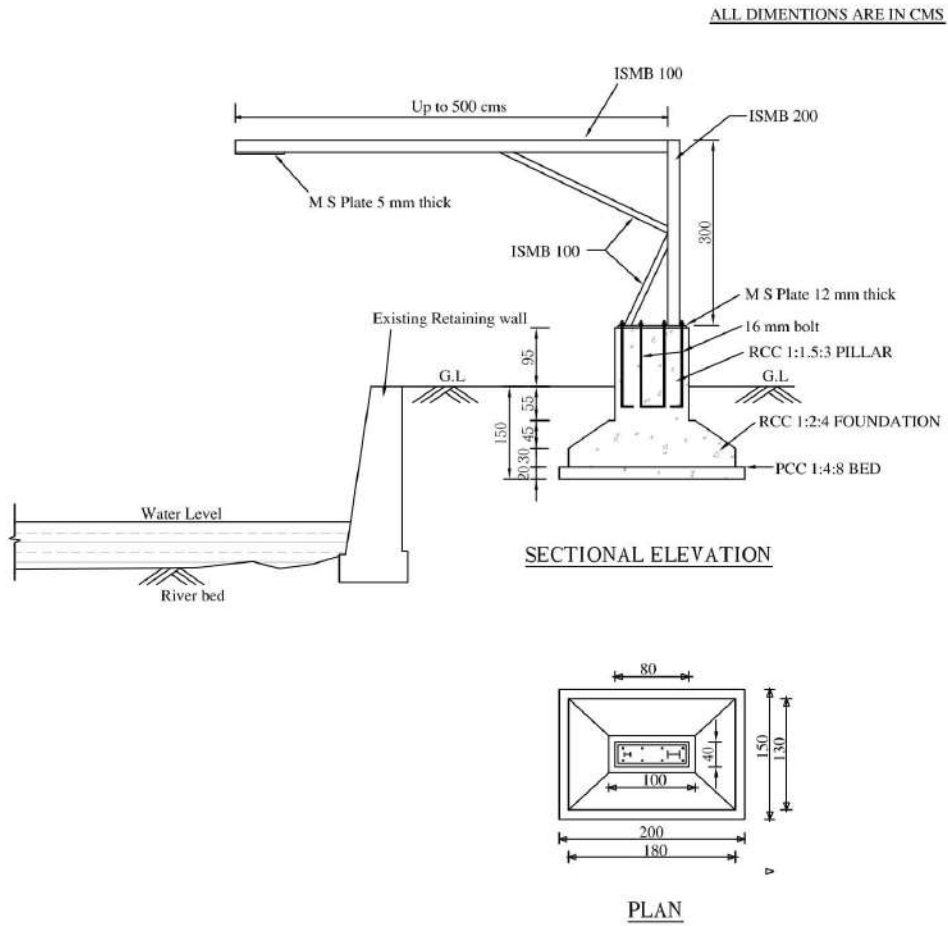
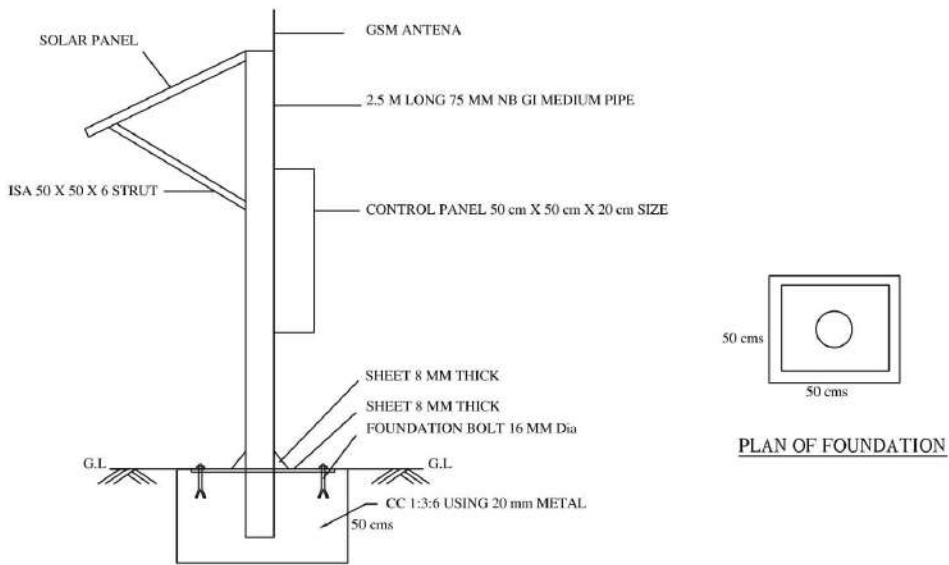
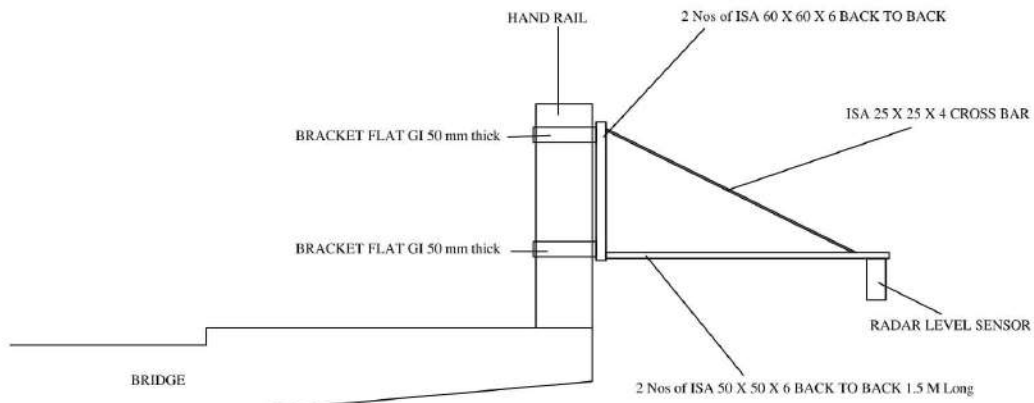

Fig 6: Typical Solar Panel Support and AWLR Radar Support on Bridge



CONTROL PANEL AND SOLAR PANEL FRAMING DETAILS



RADAR SENSOR FARMING TO BRIDGE DETAILS

5. INSPECTIONS AND TESTS

The following inspections and tests shall be performed:

5.1 General:

1. After manufacture, the supplier shall get each equipment/item of Goods inspected in manufacturer/s works as per approved datasheets and QAP and forward to the Purchaser along with his letter seeking to inspect an equipment/item of Goods conforming to Contract specifications.
2. Upon receipt of the test certificate and calibration certificates, the purchaser or its representative shall arrange for inspection and/or test of any or part or all the equipment /Goods prior to issuance of dispatch clearance. In cases where the supplies are received from abroad, the purchaser may waive the pre-dispatch inspection.
3. However, the inspection and dispatch clearance by the Purchaser or the waiver thereof shall not prejudice the right of the Purchaser or its consignee to test the equipment/goods on receipt at destination. Upon receipt of the goods at final destination, the Purchaser shall have the right to inspect and/or test the equipment/Goods to confirm their conformity to Contract specifications.
4. If the equipment fails to meet the Contract specifications during inspection, whether pre-dispatch or upon receipt at final destination, the supplier shall take immediate steps to remedy the deficiency or replace the defective equipment to ensure that all supplies meet with the specifications specified in the Contract

5.2 Inspection and tests prior to shipment of Goods and at final acceptance are as follows:

1. The inspection of the Goods shall be carried out to check whether the Goods are in conformity with the approved technical specifications attached to the Contract and shall be in line with the inspection/test procedures laid down in the Technical Specifications and the General Conditions of Contract. Following broad test procedure will generally be followed for inspection and testing of equipment. The supplier will dispatch the goods to the ultimate consignee after internal inspection testing along with the supplier's inspection report and manufacturer's warranty certificate. The purchaser will test the equipment after completion of the installation and commissioning at the site of the installation.
 - a. Site Preparation and Installation: The Purchaser will designate the installation sites before the scheduled installation date to allow the Supplier to perform a site inspection before the installation of the RTDAS and associated telemetry system
 - b. For site preparation, the supplier should furnish all details to the purchaser sufficiently in advance so as to get the works completed before receipt of the equipment.
2. Complete hardware and software as specified in 'List of Goods and Delivery Schedule' Under the Schedule of Requirement should be supplied, installed and commissioned properly by the supplier prior to commencement of performance tests.

3. The acceptance test will be conducted by the purchaser/their consultant or any other person nominated by the purchaser, at its option. The acceptance will involve trouble-free operation for Fifteen consecutive days. There shall not be any additional charges for carrying out acceptance tests. No malfunction, partial or complete failure of any part of hardware, equipment's, Data Servers attached to printers, drivers etc. or bugs in the software should occur. The supplier shall maintain necessary log in respect of the results of the tests to establish to the entire satisfaction of the purchaser, the successful completion of the test specified. An average uptake efficiency of 95% for the duration of test period shall be considered as satisfactory.
4. In the event of the equipment's & hardware failing to pass the acceptance test, a period not exceeding two weeks will be given to rectify the defects and clear the acceptance test, failing which the purchaser reserves the rights to get the equipment replaced by the supplier at no extra cost to the purchaser.
5. RTDAS system procured would be subject to the Acceptance Protocol given below

5.3ACCEPTANCE PROTOCOL

General

- a) The delivery of goods/equipment and software (if applicable) should be in accordance with the Contract agreement and the process of delivery will adhere to the following 'Acceptance Protocol'. The Acceptance Protocol shall serve as a formal guidance during delivery of the RTDAS system. Its primary goals are twofold.
 - (i) Ascertain the delivery and completeness of all ordered products and related documents.
 - (ii) Check the functioning of the equipment's of RTDAS system in a formal way against the specifications by application of Acceptance Tests. The tests also verify the accuracy and stability of the equipment.
- b) The Acceptance Protocol shall be executed in close co-operation between the Supplier and the Client.
- c) Products shall be accepted only if they meet the requirements and are functioning in compliance with the approved technical specifications, approved QAP and the related documents are complete and correct. Defective products and any other discrepancies shall have to be replaced/ resolved, within a pre-defined time frame.

The following documents shall accompany the delivery of the RTDAS system:

- i. Administrative and Quality Assurance (QA) documents
- ii. Test and calibration documents
- iii. Manuals and Guidelines

All documents shall have identification and references to subject or instrument, date, time, location and officer in charge.

- d) The Acceptance Report lays down the findings and observations during the execution of the Acceptance Protocol and is a formal document to record the acceptance or rejection of any item as covered in the Bid document. Any flaws or findings are to be reported. The forms and checklists filled out during the execution of the Acceptance

Protocol are to be enclosed with the Acceptance Report. The Supplier receives a signed copy of the Acceptance Report, which the Supplier can use as proof that the items listed in the report were accepted.

e. The content of the various documents shall be as follows:

5.4 Administrative and QA documents: These QA documents shall include:

- i) Production documents associated with the instruments.
- ii) Type codes, serial numbers and other identification data on, possibly externally procured, sensors and major assemblies, to clearly demarcate the sensors/major assemblies associated with RTDAS system.
- iii) Shipping documents indicating instrument/product type, serial number, measuring range, cable length and other similar data.

5.5 Test and calibration documents:

- i) A comprehensive Method Statement on the applied calibration and in-factory test procedures shall accompany the bid. The Method Statement should define the test and calibration methods applied on the instruments and the components thereof. The Method Statement shall also include, for each calibrated product, an audit trail to national standards on all instruments and facilities used for testing and calibration. The Audit Trail Report shall associate the calibration of the reference instruments and test equipment to the national calibration standards.
- ii) If the Supplier or Manufacturer is not in a position to deliver an Audit Trail Report to the national standards, the Manufacturer shall explain what the quality standards are and how they are maintained and monitored.
- iii) Conditions during calibration, such as room and/or instrument temperature, equipment and facilities used, shall be included in the calibration and test documents.
- iv) The test and calibration documents (QAP) shall contain the data generated during calibration and testing, including:
 - Calibration data provided by the Manufacturer for all instruments
 - Calibration and test data of the data-logger electronics
 - Data on hysteresis test, temperature tests, zero stability test, scale stability test
 - Humidity test
 - Spray test on enclosure(s), connectors and cables

5.6 Manuals and Guidelines

- i) The manuals shall meet the requirements on style and clarity, completeness, preciseness, detail and accessibility. This includes:
 - System manual,
 - Operation, Maintenance and Service manuals,
 - Observation guideline, and
 - Training handouts.

5.7 Acceptance Tests

General:

- i) Qualified engineers under responsibility of a test manager shall execute the Acceptance Tests. The progress of the Acceptance Tests would be monitored and supervised by the Client and/or his authorized representative. The Client may have any tests redone or additional tests executed as deemed required based on the results of previous tests conducted. The Client's and/or his authorized representative shall have the right of access to any instrument and may request any data or information at any time. The Supplier has the obligation to deliver requested information without delay; i.e. collected test data and documents must be available at the test site.
- ii) It is important that all activities (what, when, where, who, which instrument, etc.) are annotated and uniquely linked to the individual instruments.
- iii) The Acceptance Tests mainly comprise three levels viz.:
 - **Functional Tests:** The
 - Functional Tests shall verify the proper functioning of the instruments and the associated software. Primary goal is to verify that the instrument performs its functions according to the bid specifications.
 - **Accuracy Tests:** The Accuracy Tests shall verify that each individual instrument is functional and operates according to the bid specifications. A number of relatively simple accuracy tests are routinely exercised on the instruments.
 - **Overall Test:** The main purpose of the Overall Test is to verify the common features that are identical to all the instruments in a series. Typical components of the Overall Test are: in-built software functions of instruments, materials of the instrument, cables, connectors, etc. Further tests include battery and memory autonomy, details of sensor specifications like temperature effects, hysteresis, long term stability etc.
 - The above tests can be executed at any one of the following locations: -Premises of the Manufacturer/Supplier; Premises of the Client; Independent organization; at Site of installation
- iv) The charges for testing shall be borne by the Manufacturer/Supplier. The Client and/or his authorized representative may at his cost opt to be present during the performances of the tests.

5.8 Site Acceptance Protocol

In order to facilitate the site acceptance of the system by the site – in – charges, the Bidder should give a list of deliverables for each site to the respective sites as well

as to the headquarters. The list shall be verified by the site – in – charge and accordingly will give a verification report whether all deliverables have been delivered properly at the site. The Bidder should preferably, complete the required civil works at the site for proper installation of the equipment before supplying the equipment at the site.

For site acceptance test, the supplier should give a check – list of all components and their functions. This check list shall be decided in consultation with the purchaser. This check list shall indicate the tests to be conducted at the site and the results that are expected for each and every component that are to be installed at the site. This check list will have to be provided to each and every site one month before the installation begins.

5.9 Site Acceptance Tests (SAT)for Remote Stations

The acceptance test will be conducted by the purchaser or any other person nominated by the purchaser, at its option. Site acceptance test shall be carried out in two stages. The first stage of acceptance will be based on preliminary inspection of the equipment supplied with respect to the required and supplied components such as sensors, DCP with the weather proof enclosures, batteries (charger/ regulator), gauge apparatus with enclosures and sensors, transmitter, antenna, solar panel and mounting hardware, including all associated accessories.

Second stage of site testing shall be undertaken for a period of 15 days following successful completion of witnessed commissioning to prove the equipment and the interconnecting cable installation and ensure that all operators are fully conversant with the equipment and calibration procedures, methods of operation and all facilities provided by software. During the period of 15 days, there shall be no occurrence of any malfunction in any component necessitating replacement or repairs. No malfunction, partial or complete failure of any part of hardware or excessive heating of motors or other electro-mechanical equipment or bugs in the software should occur. All the software should be complete and no missing modules/ sections will be allowed. The supplier shall maintain necessary log in respect of the results of the tests to establish to the entire satisfaction of the purchaser, the successful completion of the test specified. An average data acquisition efficiency of 95% for the duration of test period shall be considered as satisfactory. The testing schedule will be agreed to by both the parties during performance of Contract. In this stage a regular comprehensive check of functioning of all the components will be made. On conclusion of site acceptance, all relevant documentation pertaining to the site shall be handed over by the supplier to the representative of the purchaser.

5.10 Data Centre Level Acceptance Tests

Data Centre Level acceptance tests shall involve successful receiving of remote stations data at the State Data Centers server. It shall include (hardware and software), data dissemination software indicating their full implementation as specified and trouble-free operation of all modules for a period of 3 days operating on 24 X 7 basis. An average data acquisition efficiency of 95% for the duration of test period shall be considered as satisfactory.

5.11 Spare parts

Bidder shall provide the list of mandatory spare parts & ensure the availability of sufficient spare parts in its godown for fulfilling its service obligations during warranty period. The same can be inspected by Engineer-in Charge or its authorized representative.

5.12 Manuals

- Before the goods and equipment are taken over by the Purchaser, the Supplier shall supply operation and maintenance manuals of the goods and equipment. These shall be in such detail as will enable the Purchaser to operate, maintain, adjust and repair all parts of the equipment as stated in the specifications.
- The manuals shall be in the ruling language (English) and in such form and numbers as stated in the Contract.
- Unless and otherwise agreed, the goods and equipment shall not be considered to be completed for the purpose of taking over until such manuals have been supplied to the Purchaser.

5.13 For the System and Other Software the following will apply:

The Supplier shall provide complete and legal documentation of hardware, and licensed operating systems. The supplier shall also indemnify the purchaser against any levies/penalties on account of any default in this regard.

5.14 Acceptance Certificates:

- On successful completion of acceptability test, receipt of deliverables etc., and after the purchaser is satisfied with the working of the RTDAS system, the acceptance certificate signed by the supplier and the representative of the purchaser will be issued. The date on which such certificate is signed shall be deemed to be the date of successful commissioning of the systems.

**6. PROFORMA OF CERTIFICATE FOR ISSUE BY THE PURCHASER
AFTER SUCCESSFUL INSTALLATION AND STARTUP OF THE
SUPPLIED GOODS**

[This is to be attached for supply, erection, supervision of erection and startup Contracts only]

No.

Date:

M/s.

Sub: Certificate of startup of the supplied Goods

1. This is to certify that the plant/s as detailed below has/have been received in good condition along with all the standard and special accessories (subject to remarks in Para No. 2) and a set of spares in accordance with the Contract/Specifications. The same has been installed and commissioned.

(a) Contract No. _____ dated _____

(b) Description of the plant _____

(c) Plant Nos. _____

(d) Quantity

(e) Rail/Roadways Receipt No.
_____ dated _____

(f) Name of the consignee

(g) Date of startup and proving test _____

2. Details of accessories/spares not yet supplied and recoveries to be made on that account.

<u>S. No.</u>	<u>Description</u>	<u>Amount to be recovered</u>
---------------	--------------------	-------------------------------

3. The proving test has been done to our entire satisfaction and operators have been trained to operate the plant.

4. The supplier has fulfilled his Contractual obligations satisfactorily. *

or

The supplier has failed to fulfill his Contractual obligations with regard to the following:

(a)

(b)

(c)

(d)

5. The amount of recovery on account of non-supply of accessories and spares is given under Para No. 2.

6. The amount of recovery on account of failure of the supplier to meet his Contractual obligations is as indicated in endorsement of the letter.

Signature

Name

Designation with Stamp

* Explanatory notes for filling up the certificates:

- (a) He has adhered to the time schedule specified in the Contract in dispatching the documents/drawings pursuant to Technical Specifications.
- (b) He has supervised the startup of the plan in time i.e., within the period specified in the Contract from the date of intimation by the Purchaser in respect of the installation of the plant.
- (c) Training of personnel has been done by the supplier as specified in the Contract
- (d) In the event of documents/drawings having not been supplied or installation and startup of the plant have been delayed on account of the supplier, the extent of delay should always be mentioned.

PART 3 – CONTRACT

SECTION VIII – GENERAL CONDITIONS OF CONTRACT

Section VIII. General Conditions of Contract

Table of Clauses

1.	DEFINITIONS.....	19898
2.	CONTRACT DOCUMENTS	199
3.	CORRUPT & FRAUDULENT PRACTICES.....	199
4.	INTERPRETATION.....	199
5.	LANGUAGE	200
6.	JOINT VENTURE, CONSORTIUMS OR ASSOCIATION.....	200
7.	ELIGIBILITY	200
8.	NOTICES.....	201
9.	GOVERNING LAW.....	201
10.	SETTLEMENT OF DISPUTES	201
11.	INSPECTIONS AND AUDIT BY THE BANK	201
12.	SCOPE OF SUPPLY	202
13.	DELIVERY AND DOCUMENTS	202
14.	SUPPLIER'S RESPONSIBILITIES	202
15.	CONTRACT PRICE.....	202
16.	TERMS OF PAYMENT.....	202
17.	TAXES AND DUTIES.....	203
18.	PERFORMANCE SECURITY	203
19.	COPYRIGHT.....	203
20.	CONFIDENTIAL INFORMATION	203
21.	SUBCONTRACTING	204
22.	SPECIFICATIONS AND STANDARDS	204
23.	PACKING AND DOCUMENTS	205
24.	INSURANCE.....	205
25.	TRANSPORTATION& INCIDENTAL SERVICES.....	205
26.	INSPECTIONS AND TESTS.....	206
27.	LIQUIDATED DAMAGES	207
28.	WARRANTY	207
29.	PATENT INDEMNITY.....	208
30.	LIMITATION OF LIABILITY	209
31.	CHANGE IN LAWS AND REGULATIONS.....	209
32.	FORCE MAJEURE	210
33.	CHANGE ORDERS AND CONTRACT AMENDMENTS.....	210
34.	EXTENSIONS OF TIME.....	211
35.	TERMINATION.....	211
36.	ASSIGNMENT.....	212

Section VIII. General Conditions of Contract

1. Definitions

The following words and expressions shall have the meanings hereby assigned to them:

- (a) “Bank” means the World Bank and refers to the International Bank for Reconstruction and Development (IBRD) or the International Development Association (IDA).
- (b) “Contract” means the Contract Agreement entered into between the Purchaser and the Supplier, together with the Contract Documents referred to therein, including all attachments, appendices, and all documents incorporated by reference therein.
- (c) “Contract Documents” means the documents listed in the Contract Agreement, including any amendments thereto.
- (d) “Contract Price” means the price payable to the Supplier as specified in the Contract Agreement, subject to such additions and adjustments thereto or deductions therefrom, as may be made pursuant to the Contract.
- (e) “Day” means calendar day.
- (f) “Completion” means the fulfillment of the Related Services by the Supplier in accordance with the terms and conditions set forth in the Contract.
- (g) “GCC” means the General Conditions of Contract.
- (h) “Goods” means all of the commodities, raw material, machinery and equipment, and/or other materials that the Supplier is required to supply to the Purchaser under the Contract.
- (i) “Purchaser’s Country” is India.
- (j) “Purchaser” means the entity purchasing the Goods and Related Services, as specified in the **SCC**.
- (k) “Related Services” means the services incidental to the supply of the goods, such as insurance, installation, start-up, training and initial maintenance and other such obligations of the Supplier under the Contract.
- (l) “SCC” means the Special Conditions of Contract.
- (m) “Sub-Contractor” means any natural person, private or

government entity, or a combination of the above, to whom any part of the Goods to be supplied or execution of any part of the Related Services is subContracted by the Supplier.

- (n) "Supplier" means the natural person, private or government entity, or a combination of the above, whose bid to perform the Contract has been accepted by the Purchaser and is named as such in the Contract Agreement.
- (o) "The Project Site," where applicable, means the place named in the SCC.

2. Contract Documents

2.1 Subject to the order of precedence set forth in the Contract Agreement, all documents forming the Contract (and all parts thereof) are intended to be correlative, complementary, and mutually explanatory. The Contract Agreement shall be read as a whole.

3. Corrupt & Fraudulent Practices

- 3.1 The Bank requires compliance with its policy in regard to corrupt and fraudulent practices as set forth in Appendix to the GCC.
- 3.2 The Purchaser requires the Supplier to disclose any commissions or fees that may have been paid or are to be paid to agents or any other party with respect to the bidding process or execution of the Contract. The information disclosed must include at least the name and address of the agent or other party, the amount and currency, and the purpose of the commission, gratuity or fee.

4. Interpretation

- 4.1 If the context so requires it, singular means plural and vice versa.
- 4.2 Incoterms.
 - (a) Unless inconsistent with any provision of the Contract, the meaning of any trade term and the rights and obligations of parties thereunder shall be as prescribed by Incoterms.
 - (b) The terms EXW and other similar terms, when used, shall be governed by the rules prescribed in the current edition of Incoterms specified in the SCC and published by the International Chamber of Commerce in Paris, France.

4.3 Entire Agreement

The Contract constitutes the entire agreement between the Purchaser and the Supplier and supersedes all communications, negotiations and agreements (whether written or oral) of the parties with respect thereto made prior to the date of Contract.

4.4 Amendment

No amendment or other variation of the Contract shall be valid unless it is in writing, is dated, expressly refers to the Contract, and is signed by a duly authorized representative of each party thereto.

4.5 Nonwaiver

- (a) Subject to GCC Sub-Clause 4.5(b) below, no relaxation, forbearance, delay, or indulgence by either party in enforcing any of the terms and conditions of the Contract or the granting of time by either party to the other shall prejudice, affect, or restrict the rights of that party under the Contract, neither shall any waiver by either party of any breach of Contract operate as waiver of any subsequent or continuing breach of Contract.
- (b) Any waiver of a party's rights, powers, or remedies under the Contract must be in writing, dated, and signed by an authorized representative of the party granting such waiver, and must specify the right and the extent to which it is being waived.

4.6 Severability

If any provision or condition of the Contract is prohibited or rendered invalid or unenforceable, such prohibition, invalidity or unenforceability shall not affect the validity or enforceability of any other provisions and conditions of the Contract.

5. Language

5.1 The Contract as well as all correspondence and documents relating to the Contract exchanged by the Supplier and the Purchaser, shall be English. Supporting documents and printed literature that are part of the Contract may be in another language provided they are accompanied by an accurate translation of the relevant passages in English language, in which case, for purposes of interpretation of the Contract, this translation shall govern.

5.2 The Supplier shall bear all costs of translation to the governing language and all risks of the accuracy of such translation, for documents provided by the Supplier.

6. Joint Venture, Consortium or Association

6.1 If the Supplier is a joint venture, consortium, or association, all of the parties shall be jointly and severally liable to the Purchaser for the fulfillment of the provisions of the Contract and shall designate one party to act as a leader with authority to bind the joint venture, consortium, or association. The composition or the constitution of the joint venture, consortium, or association shall not be altered without the prior consent of the Purchaser.

7. Eligibility

7.1 The Supplier and its Sub-Contractors shall have the nationality of an eligible country. A Supplier or Sub-Contractor shall be

deemed to have the nationality of a country if it is a citizen or constituted, incorporated, or registered, and operates in conformity with the provisions of the laws of that country.

7.2 All Goods and Related Services to be supplied under the Contract and financed by the Bank shall have their origin in Eligible Countries. For the purpose of this Clause, origin means the country where the goods have been grown, mined, cultivated, produced, manufactured, or processed; or through manufacture, processing, or assembly, another commercially recognized article results that differs substantially in its basic characteristics from its components.

8. Notices

8.1 Any notice given by one party to the other pursuant to the Contract shall be in writing to the address specified in the **SCC**. The term “in writing” means communicated in written form with proof of receipt.

8.2 A notice shall be effective when delivered or on the notice’s effective date, whichever is later.

9. Governing Law

9.1 The Contract shall be governed by and interpreted in accordance with the laws of the Union of India.

10. Settlement of Disputes

10.1 The Purchaser and the Supplier shall make every effort to resolve amicably by direct informal negotiation any disagreement or dispute arising between them under or in connection with the Contract.

10.2 If, after twenty-eight (28) days, the parties have failed to resolve their dispute or difference by such mutual consultation, then either the Purchaser or the Supplier may give notice to the other party of its intention to commence arbitration, as hereinafter provided, as to the matter in dispute, and no arbitration in respect of this matter may be commenced unless such notice is given. Any dispute or difference in respect of which a notice of intention to commence arbitration has been given in accordance with this Clause shall be finally settled by arbitration. Arbitration may be commenced prior to or after delivery of the Goods under the Contract. Arbitration proceedings shall be conducted in accordance with the rules of procedure **specified in the SCC**.

10.3 Notwithstanding any reference to arbitration herein,

(a) the parties shall continue to perform their respective obligations under the Contract unless they otherwise agree; and

(b) the Purchaser shall pay the Supplier any monies due the Supplier.

11. Inspections and

11.1 The Supplier shall keep, and shall make all reasonable efforts to

Audit by the Bank	<p>cause its Sub-Contractors to keep, accurate and systematic accounts and records in respect of the Goods in such form and details as will clearly identify relevant time changes and costs</p> <p>11.2 The Supplier shall permit, and shall cause its Sub-Contractors to permit, the Bank and/or persons appointed by the Bank to inspect the Supplier's offices and all accounts and records relating to the performance of the Contract and the submission of the bid, and to have such accounts and records audited by auditors appointed by the Bank if requested by the Bank. The Supplier's and its Sub-Contractors and consultants' attention is drawn to Clause 3 [Fraud and Corruption], which provides, inter alia, that acts intended to materially impede the exercise of the Bank's inspection and audit rights provided for under this Sub-Clause 11.1 constitute a prohibited practice subject to Contract termination (as well as to a determination of ineligibility pursuant to the Bank's prevailing sanctions procedures)</p>
12. Scope of Supply	<p>12.1 The Goods and Related Services to be supplied shall be as specified in the Special Conditions of Contract.</p>
13. Delivery and Documents	<p>13.1 Subject to GCC Sub-Clause 33.1, the Delivery of the Goods and Completion of the Related Services shall be in accordance with the Delivery and Completion Schedule specified in the Schedule of Requirements. The details of shipping and other documents to be furnished by the Supplier are specified in the SCC.</p>
14. Supplier's Responsibilities	<p>14.1 The Supplier shall supply all the Goods and Related Services included in the Scope of Supply in accordance with GCC Clause 12, and the Delivery and Completion Schedule, as per GCC Clause 13.</p>
15. Contract Price	<p>15.1 Prices charged by the Supplier for the Goods supplied and the Related Services performed under the Contract shall not vary from the prices quoted by the Supplier in its bid, with the exception of any price adjustments authorized in the SCC.</p>
16. Terms of Payment	<p>16.1 The Contract Price, including any Advance Payments, if applicable, shall be paid as specified in the SCC.</p> <p>16.2 The Supplier's request for payment shall be made to the Purchaser in writing, accompanied by invoices describing, as appropriate, the Goods delivered and Related Services performed, and by the documents submitted pursuant to GCC Clause 13 and upon fulfillment of all other obligations stipulated in the Contract.</p> <p>16.3 Payments shall be made promptly by the Purchaser, but in no case later than sixty (60) days after submission of an invoice or request for payment by the Supplier, and after the Purchaser has accepted it.</p> <p>16.4 The payments shall be made in Indian Rupees to the Supplier</p>

under this Contract.

16.5 In the event that the Purchaser fails to pay the Supplier any payment by its due date or within the period set forth in the **SCC**, the Purchaser shall pay to the Supplier interest on the amount of such delayed payment at the rate shown in the **SCC**, for the period of delay until payment has been made in full, whether before or after judgment or arbitration award.

17. Taxes and Duties

17.1 The Supplier shall be entirely responsible for all taxes, duties, license fees, etc., incurred until delivery of the Contracted Goods to the Purchaser.

18. Performance Security

18.1 If required as specified in the **SCC**, the Supplier shall, within twenty-one (21) days of the notification of Contract award, provide a performance security for the performance of the Contract in the amount specified in the **SCC**.

18.2 The proceeds of the Performance Security shall be payable to the Purchaser as compensation for any loss resulting from the Supplier's failure to complete its obligations under the Contract.

18.3 As specified in the **SCC**, the Performance Security shall be denominated in the Indian Rupees, and shall be in the format stipulated by the Purchaser in the **SCC**, or in another format acceptable to the Purchaser.

18.4 The Performance Security shall be discharged by the Purchaser and returned to the Supplier not later than twenty-eight (28) days following the date of Completion of the Supplier's performance obligations under the Contract, including any warranty obligations, unless specified otherwise in the **SCC**.

19. Copyright

19.1 The copyright in all drawings, documents, and other materials containing data and information furnished to the Purchaser by the Supplier herein shall remain vested in the Supplier, or, if they are furnished to the Purchaser directly or through the Supplier by any third party, including suppliers of materials, the copyright in such materials shall remain vested in such third party.

20. Confidential Information

20.1 The Purchaser and the Supplier shall keep confidential and shall not, without the written consent of the other party hereto, divulge to any third party any documents, data, or other information furnished directly or indirectly by the other party hereto in connection with the Contract, whether such information has been furnished prior to, during or following completion or termination of the Contract. Notwithstanding the above, the Supplier may furnish to its Sub-Contractor such documents, data, and other information it receives from the Purchaser to the extent required for the Sub-Contractor to

perform its work under the Contract, in which event the Supplier shall obtain from such Sub-Contractor an undertaking of confidentiality similar to that imposed on the Supplier under GCC Clause 20.

20.2 The Purchaser shall not use such documents, data, and other information received from the Supplier for any purposes unrelated to the Contract. Similarly, the Supplier shall not use such documents, data, and other information received from the Purchaser for any purpose other than the performance of the Contract.

20.3 The obligation of a party under GCC Sub-Clauses 20.1 and 20.2 above, however, shall not apply to information that:

- (a) the Purchaser or Supplier need to share with the Bank or other institutions participating in the financing of the Contract;
- (b) now or hereafter enters the public domain through no fault of that party;
- (c) can be proven to have been possessed by that party at the time of disclosure and which was not previously obtained, directly or indirectly, from the other party; or
- (d) otherwise lawfully becomes available to that party from a third party that has no obligation of confidentiality.

20.4 The above provisions of GCC Clause 20 shall not in any way modify any undertaking of confidentiality given by either of the parties hereto prior to the date of the Contract in respect of the Supply or any part thereof.

20.5 The provisions of GCC Clause 20 shall survive completion or termination, for whatever reason, of the Contract.

21. SubContracting

21.1 The Supplier shall notify the Purchaser in writing of all subContracts awarded under the Contract if not already specified in the bid. Such notification, in the original bid or later shall not relieve the Supplier from any of its obligations, duties, responsibilities, or liability under the Contract.

21.2 SubContracts shall comply with the provisions of GCC Clauses 3 and 7.

22. Specifications and Standards

22.1 Technical Specifications and Drawings

- (a) The Goods and Related Services supplied under this Contract shall conform to the technical specifications and standards mentioned in Section VII, Schedule of Requirements and, when no applicable standard is mentioned, the standard shall be equivalent or superior to the official standards whose application is appropriate to the Goods' country of origin.

- (b) The Supplier shall be entitled to disclaim responsibility for any design, data, drawing, specification or other document, or any modification thereof provided or designed by or on behalf of the Purchaser, by giving a notice of such disclaimer to the Purchaser.
- (c) Wherever references are made in the Contract to codes and standards in accordance with which it shall be executed, the edition or the revised version of such codes and standards shall be those specified in the Schedule of Requirements. During Contract execution, any changes in any such codes and standards shall be applied only after approval by the Purchaser and shall be treated in accordance with GCC Clause 33.

23. Packing and Documents

- 23.1 The Supplier shall provide such packing of the Goods as is required to prevent their damage or deterioration during transit to their final destination, as indicated in the Contract. During transit, the packing shall be sufficient to withstand, without limitation, rough handling and exposure to extreme temperatures, salt and precipitation, and open storage. Packing case size and weights shall take into consideration, where appropriate, the remoteness of the goods' final destination and the absence of heavy handling facilities at all points in transit.
- 23.2 The packing, marking, and documentation within and outside the packages shall comply strictly with such special requirements as shall be expressly provided for in the Contract, including additional requirements, if any, specified in the **SCC**, and in any other instructions ordered by the Purchaser.

24. Insurance

- 24.1 Unless otherwise specified in the **SCC**, the Goods supplied under the Contract shall be fully insured—against loss or damage incidental to manufacture or acquisition, transportation, storage, and delivery, in accordance with the applicable Incoterms or in the manner specified in the **SCC**.

25. Transportation & Incidental Services

- 25.1 Unless otherwise specified in the **SCC**, responsibility for arranging transportation of the Goods shall be in accordance with the specified Incoterms.
- 25.2 The Supplier may be required to provide any or all of the following services, including additional services, if any, **specified in Schedule of Requirements and SCC**:
 - (a) performance or supervision of on-site assembly and/or start-up of the supplied Goods;
 - (b) furnishing of tools required for assembly and/or maintenance of the supplied Goods;

- (c) furnishing of a detailed operations and maintenance manual for each appropriate unit of the supplied Goods;
- (d) performance or supervision or maintenance and/or repair of the supplied Goods, for a period of time agreed by the parties, provided that this service shall not relieve the Supplier of any warranty obligations under this Contract; and
- (e) training of the Purchaser's personnel, at the Supplier's plant and/or on-site, in assembly, start-up, operation, maintenance, and/or repair of the supplied Goods

25.3 Prices charged by the Supplier for incidental services, if not included in the Contract Price for the Goods, shall be agreed upon in advance by the parties and shall not exceed the prevailing rates charged to other parties by the Supplier for similar services.

26. Inspections and Tests

26.1 The Supplier shall at its own expense and at no cost to the Purchaser carry out all such tests and/or inspections of the Goods and Related Services as are specified in the SCC.

26.2 The inspections and tests may be conducted on the premises of the Supplier or its Sub-Contractor, at point of delivery, and/or at the Goods' final destination, or in another place in the Purchaser's Country as specified in the SCC. Subject to GCC Sub-Clause 26.3, if conducted on the premises of the Supplier or its Sub-Contractor, all reasonable facilities and assistance, including access to drawings and production data, shall be furnished to the inspectors at no charge to the Purchaser.

26.3 The Purchaser or its designated representative shall be entitled to attend the tests and/or inspections referred to in GCC Sub-Clause 26.2, provided that the Purchaser bear all of its own costs and expenses incurred in connection with such attendance including, but not limited to, all traveling and board and lodging expenses.

26.4 Whenever the Supplier is ready to carry out any such test and inspection, it shall give a reasonable advance notice, including the place and time, to the Purchaser. The Supplier shall obtain from any relevant third party or manufacturer any necessary permission or consent to enable the Purchaser or its designated representative to attend the test and/or inspection.

26.5 The Purchaser may require the Supplier to carry out any test and/or inspection not required by the Contract but deemed necessary to verify that the characteristics and performance of the Goods comply with the technical specifications codes and standards under the Contract, provided that the Supplier's reasonable costs and expenses incurred in the carrying out of such test and/or inspection shall be added to the Contract Price. Further, if such test and/or inspection impedes the progress of

manufacturing and/or the Supplier's performance of its other obligations under the Contract, due allowance will be made in respect of the Delivery Dates and Completion Dates and the other obligations so affected.

- 26.6 The Supplier shall provide the Purchaser with a report of the results of any such test and/or inspection.
- 26.7 The Purchaser may reject any Goods or any part thereof that fail to pass any test and/or inspection or do not conform to the specifications. The Supplier shall either rectify or replace such rejected Goods or parts thereof or make alterations necessary to meet the specifications at no cost to the Purchaser, and shall repeat the test and/or inspection, at no cost to the Purchaser, upon giving a notice pursuant to GCC Sub-Clause 26.4.
- 26.8 The Supplier agrees that neither the execution of a test and/or inspection of the Goods or any part thereof, nor the attendance by the Purchaser or its representative, nor the issue of any report pursuant to GCC Sub-Clause 26.6, shall release the Supplier from any warranties or other obligations under the Contract.

27. Liquidated Damages

- 27.1 Except as provided under GCC Clause 32, if the Supplier fails to deliver any or all of the Goods by the Date(s) of delivery or perform the Related Services within the period specified in the Contract, the Purchaser may without prejudice to all its other remedies under the Contract, deduct from the Contract Price, as liquidated damages, a sum equivalent to the percentage specified in the **SCC** of the delivered price of the delayed Goods or unperformed Services for each week or part thereof of delay until actual delivery or performance, up to a maximum deduction of the percentage specified in those **SCC**. Once the maximum is reached, the Purchaser may terminate the Contract pursuant to GCC Clause 35.

28. Warranty

- 28.1 The Supplier warrants that all the Goods are new, unused, and of the most recent or current models, and that they incorporate all recent improvements in design and materials, unless provided otherwise in the Contract.
- 28.2 Subject to GCC Sub-Clause 22.1(b), the Supplier further warrants that the Goods shall be free from defects arising from any act or omission of the Supplier or arising from design, materials, and workmanship, under normal use in the conditions prevailing in the country of final destination.
- 28.3 Unless otherwise specified in the **SCC**, the warranty shall remain valid for twelve (12) months after the Goods, or any portion thereof as the case may be, have been delivered to and accepted at the final destination indicated in the **SCC**, or for eighteen (18) months after the date of shipment from the port

or place of loading in the country of origin, whichever period concludes earlier.

- 28.4 The Purchaser shall give notice to the Supplier stating the nature of any such defects together with all available evidence thereof, promptly following the discovery thereof. The Purchaser shall afford all reasonable opportunity for the Supplier to inspect such defects.
- 28.5 Upon receipt of such notice, the Supplier shall, within the period specified in the **SCC**, expeditiously repair or replace the defective Goods or parts thereof, at no cost to the Purchaser.
- 28.6 If having been notified, the Supplier fails to remedy the defect within the period specified in the **SCC**, the Purchaser may proceed to take within a reasonable period such remedial action as may be necessary, at the Supplier's risk and expense and without prejudice to any other rights which the Purchaser may have against the Supplier under the Contract.

29. Patent Indemnity

- 29.1 The Supplier shall, subject to the Purchaser's compliance with GCC Sub-Clause 29.2, indemnify and hold harmless the Purchaser and its employees and officers from and against any and all suits, actions or administrative proceedings, claims, demands, losses, damages, costs, and expenses of any nature, including attorney's fees and expenses, which the Purchaser may suffer as a result of any infringement or alleged infringement of any patent, utility model, registered design, trademark, copyright, or other intellectual property right registered or otherwise existing at the date of the Contract by reason of:
- (a) the installation of the Goods by the Supplier or the use of the Goods in the country where the Site is located; and
 - (b) the sale in any country of the products produced by the Goods.

Such indemnity shall not cover any use of the Goods or any part thereof other than for the purpose indicated by or to be reasonably inferred from the Contract, neither any infringement resulting from the use of the Goods or any part thereof, or any products produced thereby in association or combination with any other equipment, plant, or materials not supplied by the Supplier, pursuant to the Contract.

- 29.2 If any proceedings are brought or any claim is made against the Purchaser arising out of the matters referred to in GCC Sub-Clause 29.1, the Purchaser shall promptly give the Supplier a notice thereof, and the Supplier may at its own expense and in the Purchaser's name conduct such proceedings or claim and

any negotiations for the settlement of any such proceedings or claim.

29.3 If the Supplier fails to notify the Purchaser within twenty-eight (28) days after receipt of such notice that it intends to conduct any such proceedings or claim, then the Purchaser shall be free to conduct the same on its own behalf.

29.4 The Purchaser shall, at the Supplier's request, afford all available assistance to the Supplier in conducting such proceedings or claim, and shall be reimbursed by the Supplier for all reasonable expenses incurred in so doing.

29.5 The Purchaser shall indemnify and hold harmless the Supplier and its employees, officers, and Sub-Contractors from and against any and all suits, actions or administrative proceedings, claims, demands, losses, damages, costs, and expenses of any nature, including attorney's fees and expenses, which the Supplier may suffer as a result of any infringement or alleged infringement of any patent, utility model, registered design, trademark, copyright, or other intellectual property right registered or otherwise existing at the date of the Contract arising out of or in connection with any design, data, drawing, specification, or other documents or materials provided or designed by or on behalf of the Purchaser.

30. Limitation of Liability

30.1 Except in cases of criminal negligence or willful misconduct,

(a) the Supplier shall not be liable to the Purchaser, whether in Contract, tort, or otherwise, for any indirect or consequential loss or damage, loss of use, loss of production, or loss of profits or interest costs, provided that this exclusion shall not apply to any obligation of the Supplier to pay liquidated damages to the Purchaser, and

(b) the aggregate liability of the Supplier to the Purchaser, whether under the Contract, in tort or otherwise, shall not exceed the total Contract Price, provided that this limitation shall not apply to the cost of repairing or replacing defective equipment, or to any obligation of the supplier to indemnify the purchaser with respect to patent infringement.

31. Change in Laws and Regulations

31.1 Unless otherwise specified in the Contract, if after the date of 28 days prior to date of Bid submission, any law, regulation, ordinance, order or bylaw having the force of law is enacted, promulgated, abrogated, or changed in India, where the Site is located (which shall be deemed to include any change in interpretation or application by the competent authorities) that subsequently affects the Delivery Date and/or the Contract Price, then such Delivery Date and/or Contract Price shall be correspondingly increased or decreased, to the extent that the

Supplier has thereby been affected in the performance of any of its obligations under the Contract. Notwithstanding the foregoing, such additional or reduced cost shall not be separately paid or credited if the same has already been accounted for in the price adjustment provisions where applicable, in accordance with GCC Clause 15.

32. Force Majeure

- 32.1 The Supplier shall not be liable for forfeiture of its Performance Security, liquidated damages, or termination for default if and to the extent that its delay in performance or other failure to perform its obligations under the Contract is the result of an event of Force Majeure.
- 32.2 For purposes of this Clause, “Force Majeure” means an event or situation beyond the control of the Supplier that is not foreseeable, is unavoidable, and its origin is not due to negligence or lack of care on the part of the Supplier. Such events may include, but not be limited to, acts of the Purchaser in its sovereign capacity, wars or revolutions, fires, floods, epidemics, quarantine restrictions, and freight embargoes.
- 32.3 If a Force Majeure situation arises, the Supplier shall promptly notify the Purchaser in writing of such condition and the cause thereof. Unless otherwise directed by the Purchaser in writing, the Supplier shall continue to perform its obligations under the Contract as far as is reasonably practical and shall seek all reasonable alternative means for performance not prevented by the Force Majeure event.

33. Change Orders and Contract Amendments

- 33.1 The Purchaser may at any time order the Supplier through notice in accordance GCC Clause 8, to make changes within the general scope of the Contract in any one or more of the followings:
- (a) drawings, designs, or specifications, where Goods to be furnished under the Contract are to be specifically manufactured for the Purchaser;
 - (b) the method of shipment or packing;
 - (c) the place of delivery; and
 - (d) the Related Services to be provided by the Supplier.
- 33.2 If any such change causes an increase or decrease in the cost of, or the time required for, the Supplier’s performance of any provisions under the Contract, an equitable adjustment shall be made in the Contract Price or in the Delivery/Completion Schedule, or both, and the Contract shall accordingly be amended. Any claims by the Supplier for adjustment under this Clause must be asserted within twenty-eight (28) days

from the date of the Supplier's receipt of the Purchaser's change order.

33.3 Prices to be charged by the Supplier for any Related Services that might be needed but which were not included in the Contract shall be agreed upon in advance by the parties and shall not exceed the prevailing rates charged to other parties by the Supplier for similar services.

33.4 Subject to the above, no variation in or modification of the terms of the Contract shall be made except by written amendment signed by the parties.

34. Extensions of Time

34.1 If at any time during performance of the Contract, the Supplier or its Sub-Contractors should encounter conditions impeding timely delivery of the Goods or completion of Related Services pursuant to GCC Clause 13, the Supplier shall promptly notify the Purchaser in writing of the delay, its likely duration, and its cause. As soon as practicable after receipt of the Supplier's notice, the Purchaser shall evaluate the situation and may at its discretion extend the Supplier's time for performance, in which case the extension shall be ratified by the parties by amendment of the Contract.

34.2 Except in case of Force Majeure, as provided under GCC Clause 32, a delay by the Supplier in the performance of its Delivery and Completion obligations shall render the Supplier liable to the imposition of liquidated damages pursuant to GCC Clause 26, unless an extension of time is agreed upon, pursuant to GCC Sub-Clause 34.1.

35. Termination

35.1 Termination for Default

(a) The Purchaser, without prejudice to any other remedy for breach of Contract, by written notice of default sent to the Supplier, may terminate the Contract in whole or in part:

(i) if the Supplier fails to deliver any or all of the Goods within the period specified in the Contract, or within any extension thereof granted by the Purchaser pursuant to GCC Clause 34;

(ii) if the Supplier fails to perform any other obligation under the Contract; or

(iii) if the Supplier, in the judgment of the Purchaser has engaged in fraud and corruption, as defined in GCC Clause 3, in competing for or in executing the Contract.

(b) In the event the Purchaser terminates the Contract in whole or in part, pursuant to GCC Clause 35.1(a), the Purchaser may

procure, upon such terms and in such manner as it deems appropriate, Goods or Related Services similar to those undelivered or not performed, and the Supplier shall be liable to the Purchaser for any additional costs for such similar Goods or Related Services. However, the Supplier shall continue performance of the Contract to the extent not terminated.

35.2 Termination for Insolvency.

- (a) The Purchaser may at any time terminate the Contract by giving notice to the Supplier if the Supplier becomes bankrupt or otherwise insolvent. In such event, termination will be without compensation to the Supplier, provided that such termination will not prejudice or affect any right of action or remedy that has accrued or will accrue thereafter to the Purchaser.

35.3 Termination for Convenience.

- (a) The Purchaser, by notice sent to the Supplier, may terminate the Contract, in whole or in part, at any time for its convenience. The notice of termination shall specify that termination is for the Purchaser's convenience, the extent to which performance of the Supplier under the Contract is terminated, and the date upon which such termination becomes effective.
- (b) The Goods that are complete and ready for shipment within twenty-eight (28) days after the Supplier's receipt of notice of termination shall be accepted by the Purchaser at the Contract terms and prices. For the remaining Goods, the Purchaser may elect:
 - (i) to have any portion completed and delivered at the Contract terms and prices; and/or
 - (ii) to cancel the remainder and pay to the Supplier an agreed amount for partially completed Goods and Related Services and for materials and parts previously procured by the Supplier.

36. Assignment

- 36.1 Neither the Purchaser nor the Supplier shall assign, in whole or in part, their obligations under this Contract, except with prior written consent of the other party.

APPENDIX TO GENERAL CONDITIONS

Bank's Policy- Corrupt and Fraudulent Practices

(text in this Appendix shall not be modified)

Guidelines for Procurement of Goods, Works, and Non-Consulting Services under IBRD Loans and IDA Credits & Grants by World Bank Borrowers, dated January 2011:

“Fraud and Corruption:

1.16 It is the Bank's policy to require that Borrowers (including beneficiaries of Bank loans), bidders, suppliers, Contractors and their agents (whether declared or not), sub-Contractors, sub-consultants, service providers or suppliers, and any personnel thereof, observe the highest standard of ethics during the procurement and execution of Bank-financed Contracts.¹³ In pursuance of this policy, the Bank:

- (a) defines, for the purposes of this provision, the terms set forth below as follows:
 - (i) “corrupt practice” is the offering, giving, receiving, or soliciting, directly or indirectly, of anything of value to influence improperly the actions of another party;¹⁴
 - (ii) “fraudulent practice” is any act or omission, including a misrepresentation, that knowingly or recklessly misleads, or attempts to mislead, a party to obtain a financial or other benefit or to avoid an obligation;¹⁵
 - (iii) “collusive practice” is an arrangement between two or more parties designed to achieve an improper purpose, including to influence improperly the actions of another party;¹⁶
 - (iv) “coercive practice” is impairing or harming, or threatening to impair or harm, directly or indirectly, any party or the property of the party to influence improperly the actions of a party;¹⁷

¹³ In this context, any action to influence the procurement process or contract execution for undue advantage is improper.

¹⁴ For the purpose of this sub-paragraph, “*another party*” refers to a public official acting in relation to the procurement process or contract execution. In this context, “*public official*” includes World Bank staff and employees of other organizations taking or reviewing procurement decisions.

¹⁵ For the purpose of this sub-paragraph, “*party*” refers to a public official; the terms “*benefit*” and “*obligation*” relate to the procurement process or contract execution; and the “*act or omission*” is intended to influence the procurement process or contract execution.

¹⁶ For the purpose of this sub-paragraph, “*parties*” refers to participants in the procurement process (including public officials) attempting either themselves, or through another person or entity not participating in the procurement or selection process, to simulate competition or to establish bid prices at artificial, non-competitive levels, or are plying to each other's bid prices or other conditions.

¹⁷ For the purpose of this sub-paragraph, “*party*” refers to a participant in the procurement process or contract execution.

- (v) "obstructive practice" is:
- (aa) deliberately destroying, falsifying, altering, or concealing of evidence material to the investigation or making false statements to investigators in order to materially impede a Bank investigation into allegations of a corrupt, fraudulent, coercive or collusive practice; and/or threatening, harassing or intimidating any party to prevent it from disclosing its knowledge of matters relevant to the investigation or from pursuing the investigation, or
 - (bb) acts intended to materially impede the exercise of the Bank's inspection and audit rights provided for under paragraph 1.16(e) below.
- (b) will reject a proposal for award if it determines that the bidder recommended for award, or any of its personnel, or its agents, or its sub-consultants, sub-Contractors, service providers, suppliers and/or their employees, has, directly or indirectly, engaged in corrupt, fraudulent, collusive, coercive, or obstructive practices in competing for the Contract in question;
- (c) will declare mis-procurement and cancel the portion of the loan allocated to a Contract if it determines at any time that representatives of the Borrower or of a recipient of any part of the proceeds of the loan engaged in corrupt, fraudulent, collusive, coercive, or obstructive practices during the procurement or the implementation of the Contract in question, without the Borrower having taken timely and appropriate action satisfactory to the Bank to address such practices when they occur, including by failing to inform the Bank in a timely manner at the time they knew of the practices;
- (d) will sanction a firm or individual, at any time, in accordance with the prevailing Bank's sanctions procedures,¹⁸ including by publicly declaring such firm or individual ineligible, either indefinitely or for a stated period of time:
(i) to be awarded a Bank-financed Contract; and (ii) to be a nominated¹⁹;
- (e) will require that a clause be included in bidding documents and in Contracts financed by a Bank loan, requiring bidders, suppliers and Contractors, and their sub-Contractors, agents, personnel, consultants, service providers, or suppliers, to permit the Bank to inspect all accounts, records, and other

¹⁸ A firm or individual may be declared ineligible to be awarded a Bank financed contract upon: (i) completion of the Bank's sanctions proceedings as per its sanctions procedures, including, inter alia, cross-debarment as agreed with other International Financial Institutions, including Multilateral Development Banks, and through the application the World Bank Group corporate administrative procurement sanctions procedures for fraud and corruption; and (ii) as a result of temporary suspension or early temporary suspension in connection with an ongoing sanctions proceeding. See footnote 14 and paragraph 8 of Appendix 1 of these Guidelines.

¹⁹ A nominated sub-contractor, consultant, manufacturer or supplier, or service provider (different names are used depending on the particular bidding document) is one which has either been: (i) included by the bidder in its pre-qualification application or bid because it brings specific and critical experience and know-how that allow the bidder to meet the qualification requirements for the particular bid; or (ii) appointed by the Borrower.

documents relating to the submission of bids and Contract performance, and to have them audited by auditors appointed by the Bank.”

SECTION IX. SPECIAL CONDITIONS OF CONTRACT

The following Special Conditions of Contract (SCC) shall supplement and / or amend the General Conditions of Contract (GCC). Whenever there is a conflict, the provisions herein shall prevail over those in the GCC.

GCC 1.1(j)	<p>The Purchaser is: The Executive Engineer Burdwan Investigation & Planning Division Irrigation & Waterways Directorate Govt. of West Bengal PurtaBhawan, 3rd Floor Purba Burdwan-713103, West Bengal</p>
GCC 1.1 (o)	<p>The Project Site(s)/Final Destination(s) is/are: <i>as mentioned in schedule of Requirements</i></p>
GCC 4.2 (a)	<p>The meaning of the trade terms shall be as prescribed by Incoterms.</p>
GCC 4.2 (b)	<p>The version edition of Incoterms shall be 2010.</p>
GCC 8.1	<p>For <u>notices</u>, the Purchaser's address shall be:</p> <p>For submission of original documents, the Purchaser's address is: The Executive Engineer Burdwan Investigation & Planning Division Irrigation & Waterways Directorate Govt. of West Bengal PurtaBhawan, 3rd Floor Purba Burdwan-713103, West Bengal Tel: +91342-2646799 Fax: +91342-2646799 e-mail: eebipd2012@gmail.com Country: INDIA</p>
GCC 10.2	<p>Settlement of Disputes</p> <p>The dispute settlement mechanism to be applied for adhoc arbitration shall be as follows:</p> <p>(a) In case of Dispute or difference arising between the Purchaser and a domestic supplier relating to any matter arising out of or connected with this agreement, such disputes or difference shall be settled in accordance with the Arbitration and Conciliation Act 1996 as amended up-to date. The arbitral tribunal shall consist of 3 arbitrators one each to be appointed by the Purchaser and the Supplier. The third Arbitrator shall be chosen by the two Arbitrators so appointed by the Parties and shall act as Presiding arbitrator. In case of failure</p>

	<p>of the two arbitrators appointed by the parties to reach upon a consensus within a period of 30 days from the appointment of the arbitrator appointed subsequently, the Presiding Arbitrator shall be appointed by the president of the institution of Engineers (India).</p> <p>(b) In the case of a dispute with a Foreign Supplier, the dispute shall be settled in accordance with provisions of UNCITRAL (United nations Commission on International Trade Law) Arbitration Rules. The Arbitral Tribunal shall consist of three Arbitrators one each to be appointed by the Purchaser and the Supplier. The third Arbitrator shall be chosen by the two Arbitrators so appointed by the parties and shall act as presiding arbitrator. In case of failure of the two arbitrators appointed by the parties to reach upon a consensus within a period of 30 days from the appointment of the arbitrator appointed subsequently, the Presiding Arbitrator shall be appointed by the President of the Institution of Engineers (India).</p> <p>(c) If one of the parties fails to appoint its arbitrator in pursuance of sub-clause (a) and (b) above, within 30 days after receipt of the notice of the appointment of its arbitrator by the other party, then the president of the Institution of Engineers (India), both in cases of the Foreign supplier as well as Indian supplier, shall appoint the arbitrator. A certified copy of the order of the President of the Institution of Engineers (India), making such an appointment shall be furnished to each of the parties.</p> <p>(d) Arbitration proceedings shall be held at Kolkata India, and the language of the arbitration proceedings and that of all documents and communications between the parties shall be English.</p> <p>(e) The decision of the majority of arbitrators shall be final and binding upon both parties. The cost and expenses of Arbitration proceedings will be paid as determined by the arbitral tribunal. However, the expenses incurred by each party in connection with the preparation, presentation etc. of its proceedings as also the fees and expenses paid to the arbitrator appointed by such party or on its behalf shall be borne by each party itself.</p> <p>(f) Where the value of the Contract is Rs. 10 million and below, the disputes or differences arising shall be referred to the Sole Arbitrator. The Sole Arbitrator should be appointed by agreement between the parties; failing such agreement, by the appointing authority namely the President of the Institution of Engineers (India).</p> <p>(g) Except otherwise agreed to by the Parties, Arbitrators should give a decision in writing within 120 days of receipt of notification of dispute.</p>
<p>GCC 12.1 and 25.2</p>	<p>The scope of supply for the Goods and Related Services to be supplied shall be as specified in the Schedule of requirement.</p>

<p>GCC 13.1</p>	<p>Details of Shipping and other Documents to be furnished by the Supplier are given below:</p> <p>GCC 13.1 Upon delivery of the goods to the transporter/consignee, the supplier shall notify the purchaser and mail the following documents to the Purchaser:</p> <ul style="list-style-type: none"> (i) Four Copies of the Supplier invoice showing Contract number, goods description, quantity, unit price, total amount; (ii) Delivery note, Railway receipt, or Road consignment note or equivalent transport document or acknowledgement of receipt of goods from the Consignee; (iii) Four Copies of packing list identifying contents of each package; (iv) Insurance certificate; (v) Manufacturer's/Supplier's warranty certificate; (vi) Inspection certificate issued by the nominated inspection agency, and the Supplier's factory inspection report; and (vii) Certificate of origin. <p>The above documents shall be received by the Purchaser before arrival of the Goods (except where it is handed over to the Consignee with all documents) and if not received, the supplier will be responsible for any consequent expenses.</p>
<p>GCC 14.1</p>	<p>ADD to GCC 14.1;</p> <p>The supplier is responsible for and obliged to conduct all contracted activities in accordance with the contract using state-of-the-art methods and economic principles and exercising all means available to achieve the performance specified in the Contract. The Supplier is obliged to work closely with the Purchaser's staff, act within its own authority and abide by directives issued by the Purchaser and implementation activities. The Supplier will abide by the job safety measures prevalent in India and will free the Purchaser from all demands or responsibilities arising from accidents or loss of life the cause of which is the supplier's negligence. The Supplier will pay all indemnities arising from such incidents and will not holding the activities of its personnel or sub-contracted personnel and will hold itself responsible for</p>

	<p>anymisbehavior/ misconduct. The Supplier will treat as confidential all data and information about the purchaser, obtained in the execution of his responsibilities, in strict confidence and will not reveal such information to any other party without the prior written approval of the Purchaser.</p>
GCC 15.1	<p>The prices charged for the Goods supplied and the related Services performed <i>shall not be</i> adjustable.</p>
GCC 16.1	<p>Payment shall be made in Indian Rupees in the following manner:</p> <p>The Bidder shall be paid 40%(as per clause i) of the Contract Price the balance 60%(as per clause ii) of the Contract Price for O&M and data communication over the next five years @ 12% per year which include 5 years period of onsite warranty as mentioned below: <i>(Note: Contract Price does not include any taxes or levies, as may be applicable and treated separately)</i></p> <p>i) Disbursement of Payment shall be as under:</p> <ul style="list-style-type: none"> • 10% of Contract Price as advance payment against Bank Guarantee • 20% of Contract Price, plus total GST amount charged in Invoice against Supply of Goods shall be released after 30 days of the successful Delivery and installation of all the instruments/ Equipment as per Schedule of Requirements and its final acceptance upon submission of the documents specified in clause 13 of SCC. • 20% of Contract Price will be paid after 30 days of testing, commissioning and final acceptance. <p>Advance payment of 10% paid against Bank Guarantee will be adjusted in 20% payment paid on testing, commissioning and final acceptance as stated above.</p> <p>ii) 60% of the Contract Price but including replacement of parts if any and seamless data communication, here onwards referred as maintenance charges over the balance 05(five) years (5 years of warranty period) shall be paid as per follows;</p> <ul style="list-style-type: none"> • 12% per Year to be paid on Half Yearly basis (6% at every six month) inclusive of GST payable on Supply of related services. The Conditions (applicable for this payment) shall be governed by Annexure I: Service Level Conditions <p>iii) Payment of GST will be against valid Invoice as per GST Act</p>

	<p><i>&Rules and submission of GST Registration Certificate along with declaration that GST Registration is valid and all liabilities towards GST have been discharged by the vendor. GST amount will be reimbursed after 30 days of submission of valid Invoice and all required documents and declaration by vendor.</i></p> <p><i>v) For all the payments to be made, against Bank guarantees, the bank guarantee shall be issued by a Scheduled Indian Bank or a foreign bank located in India. The guarantees issued by other banks should be confirmed by a Scheduled Indian Bank or a foreign bank operating in India.</i></p> <p><i>vi) Bank Guarantee for advance payment shall be released not later than 30 days after the adjustment of advance amount against payment due after testing, commissioning and final acceptance. The bank guarantee should be valid for a period of 180 days or till the date of final testing, commissioning and final acceptance whichever is later, from the date of issue of bank guarantee including claim period.</i></p> <p>The bidder shall indicate in the Price Schedules specifying all items prices shown therein including the unit prices and total prices of the goods and related services along with GST or any other duties and taxes applicable against the schedule of requirements. GST if liveable shall be paid as applicable. Any statutory variation shall be paid on submission of documentary evidence. Bidders shall be required to quote HSN code and applicable tax rates.</p> <p>“GST” means all four Acts CGST, SGST, UTGST, IGST and any other regulations by Government in relation to GST and rules thereto.</p>
GCC 16.5	<p>The payment-delay period after which the Purchaser shall pay interest to the supplier shall be 60 days.</p> <p>The interest rate that shall be applied is 2% per annum.</p>
GCC 17	<p>In the case of tax/ duty waiver, the purchaser will issue only the certificates in terms of the Government of India’s notification as per information given by supplier in form stipulated in Section IV. Supplier is solely responsible for obtaining such benefits and in case of failure to receive such benefits, the purchaser will not compensate the supplier separately.</p>
GCC 18.1	<p>Within 21 days of notification of award, the supplier shall furnish the Performance Security to the Purchaser shall be for an amount of 10% of the Contract value, valid upto 60 days after the date of completion of performance obligations including warranty obligations.</p>

	In the event of any correction of defects or replacement of defective material during the warranty period, the warranty for the corrected/ replaced material shall be extended to a further period of 12 months and the Performance Bank guarantee for proportionate value shall be extended 60 days over and above the extended warranty period.
GCC 18.3	<i>The Performance Security shall be in the form of a “Bank Guarantee” drawn in favour of “The Executive Engineer, Burdwan I&P Division”.</i>
GCC 18.4	Discharge of the performance Security shall take place not later than 60 days following the date of completion of the Supplier’s performance obligations, including the warranty obligation, under the Contract.
GCC 18.5	Add as Clause 18.5 to the GCC the following: In the event of any Contractual amendment, the Supplier shall, within 28days of receipt of such amendment, furnish the amendment to the Performance Security, rendering the same valid for the duration of the Contract, as amended for 60 days after the completion of performance obligations including warranty services obligations.
GCC 23.2	<u>Packing Instructions:</u> The Supplier will be required to make separate packages for each Consignee. Each package will be marked on three sides with proper paint/indelible ink with the following: (i) Project; (ii) Contract No.; (iii) Country of Origin of Goods; (iv) Supplier’s Name; (v) Packing List Reference Number. Suppliers should use recycled materials as much as possible for packing
GCC 24.1	The insurance shall be paid in an amount equal to 110 percent of the EXW value of the Goods from “Warehouse to warehouse (final destination)” on “All Risks” basis including War Risks and Strikes.
GCC 25.1	The Supplier is required under the Contract to transport the Goods duly insured to the specified final destination, and until the commissioning & final acceptance of each equipment, and all related costs shall be included in the Contract Price.
GCC 25.2	Incidental services to be provided are: All services under GCC clause 25.2
GCC 26.1	The inspections and tests shall be as detailed in Para 5 of Section VII-Schedule of Requirement: (a) The supplier shall get each item indicated in the Schedule of requirement inspected in manufacturer’s works or at the premises of supplier and submit a test certificate and also

	<p>manufacturer's guarantee /warranty certificate that the items conforms to the laid down specification.</p> <p>The Purchaser or its representative may inspect and /or test any or all the items to confirm their conformity to the Contract specification, prior to dispatch from the manufacturer's premises/supplier's premises. Such inspection and clearance will not prejudice the right of the consignee to inspect and test the items on receipt at destination to verify conformity to technical specification.</p> <p>If the items are fails to meet the laid down specifications the supplier shall take immediate steps to remedy the deficiency or replace the defective parts of the each to the satisfaction of the purchaser/ consignee.</p>
GCC 26.2	<p>The inspections and tests shall be:</p> <p>Any or all of the following inspection procedures and tests are required by the Purchaser.</p> <ol style="list-style-type: none"> 1. Inspection of equipment before dispatch. 2. Inspection of equipment at site of work before installation commissioning. 3. Testing of equipment at site of work after installation to ensure conformity to the specification. <p>The evaluation committee shall decide and propose necessary tests as it may deem fit for the purpose of evaluation. The detailed procedure of testing for the purpose of acceptance of the Goods and Services is given under Section VII Technical Specifications.</p>
GCC 27.1	<p>The liquidated damages shall be: 0.5% ofContract price per week or part thereof. This is applicable upto successful installation testing and commissioning. Further, for the performance towards the related services, following shall govern-</p> <p>Penalty for Faulty Stations/ Data Centre;</p> <ol style="list-style-type: none"> 1. For remote site in monsoon period Rs 3000/- per day. 2. For remote site in Non-monsoon period Rs 1000/- per day. 3. For Data Centre(both monsoon and non- monsoon period) Rs 4000/- per day. <p>The conditions when the penalty as above would be applicable, provision of clause 28.5 to be referred.</p>
GCC 27.2	<p>The maximum amount of liquidated damages shall be: 10% of the Contract price.</p>

GCC 28.3	<p>The period of validity of the Warranty shall be five years(Sixty (60) months) after successful installation, testing, commissioning and acceptance. This includes seamless communication of data through telemetry system to e-SWIS platform.</p> <p>For purposes of the Warranty, the place(s) of final destination(s) shall be: <i>Respective Hydromet instrument locations in West Bengal</i></p>
GCC 28.5	<p>Bidder shall provide at least one dedicated Service Engineer cum operator at the State Data Center for Operation of RTDAS system and ensure seamless data transfer from remote stations to ERS at Delhi & then to State data Center via Internet&e-SWIS software and also GSM/GPRS data transmission as per technical specifications. The period for repair or replacement shall be: 48Hours during monsoon /120 Hours during non-monsoon. It is the responsibility of the bidder to rectify/replace the equipment without any notice from purchaser and it is the duty of its personnel i.e. dedicated service engineer cum data entry operator to notice that site become non-operational or become faulty.</p> <p>A remote site shall be treated as faulty if it fails to respond or transmits erroneous data during six consecutive pre-programmed observation cycles. The decision of Engineer-in-Charge about errors in data shall be final and binding. If a remote site continues to remain "fail" for more than 6 hours in excess of the maintenance time schedule of 48/120 Hours. The Contractor is liable to pay penalty @ Rs. 1000/- per Day/ remote site during non-monsoon period and @Rs 3000/ per day/remote site during monsoon period (15th June to 15th October). The Day for the purpose of penalty shall be taken as failure period of 24 hours or part thereof for a particular remote site. The amount of penalty will be recovered from performance bank guarantee or payment due to bidder during warranty period.</p> <p>The penalty for faulty /data centers beyond MRTR would be Rs 4000/- per day.</p>
GCC 28.6	The maximum period shall be 14 days.
GCC 31.1	This clause will apply only to variations in GST and other taxes payable in India on the final product which is being supplied and not for variations in tax on the individual components / raw materials which go into the product.
	<p>Add the following additional sub clauses.</p> <p>37.1 Supplier integrity:</p> <p>The supplier is responsible for and obliged to conduct all Contracted</p>

	<p>activities in accordance with the Contract using state- of- the- art methods and economic principles and exercising all means available to achieve the performance specified in the Contract.</p>
	<p>37.2</p> <p>Supplier's obligations:</p> <p>The Supplier is obliged to work closely with the Purchaser's staff, act within its own authority and abide by directives issued by the Purchaser and implementation activities.</p> <p>The Supplier will abide by the job safety measures prevalent in India and will free the Purchaser from all demands or responsibilities arising from accidents or loss of life the cause of which is the supplier's negligence. The Supplier will pay all indemnities arising from such incidents and will not hold the purchaser responsible or obligated.</p> <p>The Supplier is responsible for managing the activities of its personnel or sub- Contracted personnel and will hold itself responsible for any misdemeanors.</p> <p>The Supplier will treat as confidential all data and information about the purchaser, obtained in the execution of his responsibilities, in strict confidence and will not reveal such information to any other party without the prior written approval of the Purchaser.</p>
	<p>37.3</p> <p>Site preparation and installation</p> <p>The supplier is responsible for associated civil work required for installation and commissioning of the supplies in the Schedule of Requirement under the heading of Relative services.</p>
	<p>37.4</p> <p>Hardware installation:</p> <p>The Supplier is responsible for all unpacking, assemblies, wiring, installations, cabling between hardware units and connecting to power supplies. The Supplier will test all hardware operations and accomplish all adjustments necessary for successful and continuous operation of the hardware at all installation sites.</p>

SERVICE LEVEL CONDITIONS

1. The bidder is fully responsible to keep the system functional during installation and warranty period. The bidder should take sue-moto action to repair any faulty instrument and should not wait for a complaint from purchaser to initiate action.

2. DEFINITIONS

i. REMOTE SITE

Remote site is the site at remote location where hydro-meteorological sensors are installed. The Remote site may be river gauging site, automatic weather station, automatic rain gauge station, canal gauging site, reservoir water level monitoring site, reservoir outflow monitoring site using gate sensor, groundwater level monitoring site or any combination of these sites.

ii. DATA CENTRE

Data centre is the respective server where data is expected to be received. In case of GSM & GPRS, based telemetry, the data centre is the server installed in state data centre for receiving GSM & GPRS transmission. In case of INSAT based telemetry, the Data Centre is Earth receiving station (ERS) server maintained by CWC at New Delhi/ Jaipur/ Burla.

iii. INVALID DATA

A data would be considered **invalid** if

- The value recorded / transmitted is beyond permissible limit for that variable. The examples of invalid data are negative rainfall, negative water level, relative humidity outside the range of 0-100, temperature outside the range of -40 to +60°C, any abnormally high or low number, negative values of atmospheric pressure, wind direction beyond the range of 0-360 degree etc. The valid permissible upper limits and lower limits for each monitoring variable for each site would be provided to bidder by the purchaser.
- If the sensor value recorded / transmitted is absurd values or sudden variation in the value (may be within the specified limits) which is not in-line with the actual physical parameter. (e.g. If the Water level sensor recorded / transmitted value is showing absurd sudden variation of 2mts (beyond the limits of rate of change of sensor value) with respective to the previous measurement interval, then this data is the invalid data).
- If the sensor value recorded / transmitted is having frequent / periodic gapes then the data will be considered as invalid data.

- If the sensor value recorded / transmitted is remain constant, even if there is variation in the physical parameters. (e.g. If the Water level recorded / transmitted value is showing constant / fix value even there is vervation in the water level, then this data is the invalid data)
- If the sensor value recorded / transmitted is not in line with the value of co-located automatic / manual observation of the same sensor parameter.

iv. FAILED DATA TRANSMISSION

For each remote station, each scheduled transmission (for all variables including battery voltage) would consist of one data transmission. A data transmission would be considered failed if any of the following conditions are true

- There is no transmission of data from **Remote Site**
- Data is transmitted form **remote site** but not received at **Data Centre/ERS /e-SWIS**.
- Data is recorded in datalogger but not transmitted
- Data is not recorded by datalogger
- Battery voltage and / or GPS status (GPS valid only in case of INSAT telemetry) not transmitted
- Only battery voltage is transmitted without any actual data from sensors
- Data is transmitted but data values are **invalid**.
- For automatic weather stations, data is missing / **invalid** for more than two variables
- Rainfall data is missing / **invalid** for automatic weather station

v. FAULTY STATION

A station would be considered faulty if:

- In case of hourly transmission cycle, there are six or more than six failed hourly data transmissions in a day.
- In case Datalogger is not recording any of the sensor Data / Battery voltage OR recording the **invalid** data of any of the sensor / Battery voltage for four or more than four measurement cycles.

vi. FAULTY DATA CENTRE

A Data Centre shall be treated as Faulty if

- Vital Hardware Equipment's installed by bidder at Data Centre Viz. Server, Internet, GSM modem, online 3 KVA UPS, GSM modem, Firewall system etc. are not functioning properly.
- Bidder has failed to pay the communication charges (SIM, internet, GSM/GPRS etc.) & system is not in function due to unpaid communication charges.
- Unauthorized absence of Bidders Operator/ Service engineer at Data Centre.

vii. MONSOON PERIOD

The monsoon period is defined between 15 June to 15 October or as per IMD notification every year.

viii. MAXIMUM RESPONSE TIME FOR REPAIR (MRTR)

- The MRTR for Remote station would be 48 hours during Monsoon season
- The MRTR for Remote station would be 120 hours during Non-Monsoon season
- The MRTR for Data Centre would be 24 hours during monsoon and non-monsoon season

ix. MINIMUM TIME BETWEEN REPAIRS PER STATION

- The minimum time between repairs is six months. If a station went faulty for reasons attributed to bidder and availed of MRTR once, it would not be eligible to avail the free repair period within payment period (six months)

3. PAYMENT FOR DATA RECEPTION

- The payment would be released proportion to data received at the Data centre. A table below presents the percentage of data reception and corresponding payment

Percentage of data received	Payment to be made to vendor
90-100%	100% of (6% of Contract price to be paid six monthly as per SCC clause no. 16.1 (ii))
80-89.99 %	90% of (6% of Contract price to be paid six monthly as per SCC clause no. 16.1 (ii))
70-79.99 %	80 % of (6% of Contract price to be paid six monthly as per SCC clause no. 16.1 (ii))
60-69.99 %	70 % of (6% of Contract price to be paid six monthly as per SCC clause no. 16.1 (ii))
50- 59.99%	60% of (6% of Contract price to be paid six monthly as per SCC clause no. 16.1 (ii))

40- 49.99%	40% of (6% of Contract price to be paid six monthly as per SCC clause no. 16.1 (ii))
30-39.99%	25% of (6% of Contract price to be paid six monthly as per SCC clause no. 16.1 (ii))
Below 30%	NIL of (6% of Contract price to be paid six monthly as per SCC clause no. 16.1 (ii))

The calculations for data reception percentage are as below

Data reception percentage for each station = [1- (No of Failed transmissions / No of transmissions expected)] *100

Data reception percentage for each station is calculated for payment period (six months)

Number of transmissions expected is calculated based on transmission cycle. For hourly transmission cycle, if there are 182 days in six months period, the no. of expected transmissions = 182 (days) * 24 (hourly transmission) for a given station. If a station went faulty during payment period of six months and availed of free time of MRTR (48 hours or 120 hours based on monsoon / non-monsoon period), the 2 days / 5 days period would be subtracted from no. of expected transmissions. For example, if a station went faulty during monsoon period and payment period is for 182 days, the number of transmissions expected would be calculated as:

Number of transmissions expected = (182-2) * 24; here 2 represents 48 hours' time to repair in monsoon period. However, this deduction would be allowed only once in six months period for any given station.

Total data Reception percentage

$$= \frac{\sum_{i=1}^n \text{Data reception percentage of } i^{\text{th}} \text{ station}}{n}$$

Where n is number of remote stations

- In case the percentage of data reception is below 50% continuously for 3 months, the Engineer-in-charge may initiate termination process as per GCC clause no. 35.

**Attachment: Price Adjustment Formula
(DELETED)**

SECTION X – CONTRACT FORMS

1. LETTER OF ACCEPTANCE

[letterhead paper of the Purchaser]

[date]

To: *[name and address of the Supplier]*

Subject: **Notification of Award Contract No.**

This is to notify you that your Bid dated . . . *[insert date]* . . . for execution of the . . .
. *[insert name of the Contract and identification number, as given in the
SCC]*. for the Accepted Contract Amount of *[insert amount in
numbers and words in Rupees]*, as corrected and modified in accordance with the
Instructions to Bidders is hereby accepted by our Agency.

You are requested to furnish the Performance Security within 21 days in accordance
with the Conditions of Contract, using for that purpose the of the Performance
Security Form included in Section X, Contract Forms, of the Bidding Document.

Authorized Signature: _____
Name and Title of Signatory: _____
Name of Agency: _____

Attachment: Contract Agreement

2. CONTRACT AGREEMENT

[The successful Bidder shall fill in this form in accordance with the instructions indicated]

THIS CONTRACT AGREEMENT is made

the *[insert: **number**]* day of *[insert: **month**]*, *[insert: **year**]*.

BETWEEN

- (1) *[insert complete name of Purchaser]*, a *[insert description of type of legal entity, for example, an agency of the Ministry of of the Government of {insert name of Country of Purchaser}, or corporation incorporated under the laws of {insert name of Country of Purchaser}]* and having its principal place of business at *[insert address of Purchaser]* (hereinafter called “the Purchaser”), and
- (2) *[insert name of Supplier]*, a corporation incorporated under the laws of *[insert: country of Supplier]* and having its principal place of business at *[insert: address of Supplier]* (hereinafter called “the Supplier”).

WHEREAS the Purchaser invited bids for certain Goods and ancillary services, viz., *[insert brief description of Goods and Services]* and has accepted a Bid by the Supplier for the supply of those Goods and Services in the sum of *[insert Contract Price in words and figures, expressed in Rs]* (hereinafter called “the Contract Price”).

NOW THIS AGREEMENT WITNESSETH AS FOLLOWS:

1. In this Agreement words and expressions shall have the same meanings as are respectively assigned to them in the Conditions of Contract referred to.
2. The following documents shall constitute the Contract between the Purchaser and the Supplier, and each shall be read and construed as an integral part of the Contract Agreement. This Agreement shall prevail over all other Contract documents: In the event of any discrepancy or inconsistency within the Contract documents, then the documents shall prevail in the order listed below.
 - (a) The letter of Acceptance
 - (b) this Contract Agreement
 - (c) Letter of Bid – Technical Part
 - (d) The Supplier’s letter of Bid – Financial Part and original completed Schedules including Price Schedules
 - (e) Special Conditions of Contract
 - (f) General Conditions of Contract

- (g) Technical Requirements (including Schedule of Requirements and Technical Specifications)
 - (h) *[Add here any other document(s) listed in GCC/SCC as part of Contract]*
3. In consideration of the payments to be made by the Purchaser to the Supplier as hereinafter mentioned, the Supplier hereby covenants with the Purchaser to provide the Goods and Services and to remedy defects therein in conformity in all respects with the provisions of the Contract.
 4. The Purchaser hereby covenants to pay the Supplier in consideration of the provision of the Goods and Services and the remedying of defects therein, the Contract Price or such other sum as may become payable under the provisions of the Contract at the times and in the manner prescribed by the Contract.

IN WITNESS whereof the parties hereto have caused this Agreement to be executed in accordance with the laws of *[insert the name of the Contract governing law country]* on the day, month and year indicated above.

For and on behalf of the Purchaser

Signed: *[insert signature]*
in the capacity of *[insert title or other appropriate designation]*
in the presence of *[insert identification of official witness]*

For and on behalf of the Supplier

Signed: *[insert signature of authorized representative(s) of the Supplier]*
in the capacity of *[insert title or other appropriate designation]*
in the presence of *[insert identification of official witness]*

3. Performance Security - Bank Guarantee

[Guarantor letterhead or SWIFT identifier code]

Performance Guarantee No.....*[insert guarantee reference number]*

Date.....*[insert date of issue of the guarantee]*

To: _____ *[name of Purchaser]*

_____ *[address of Purchaser]*

WHEREAS _____ *[name and address of Supplier²⁰]* (hereinafter called "the Applicant") has undertaken, in pursuance of Contract No. _____ dated _____ to execute _____ *[name of Contract and brief description of Goods and related Services]* (hereinafter called "the Contract");

AND WHEREAS it has been stipulated by you in the said Contract that the Applicant shall furnish you with a Bank Guarantee by a recognized bank for the sum specified therein as security for compliance with his obligations in accordance with the Contract;

AND WHEREAS we have agreed to give the Applicant such a Bank Guarantee;

NOW THEREFORE we hereby affirm that we are the Guarantor and responsible to you, on behalf of the Applicant, up to a total of _____ *[amount of guarantee²¹]* _____ *[in words]*, such sum being payable in the types and proportions of currencies in which the Contract Price is payable, and we undertake to pay you, upon your first written demand and without cavil or argument, any sum or sums within the limits of _____ *[amount of guarantee]* as aforesaid without your needing to prove or to show grounds or reasons for your demand for the sum specified therein.

We hereby waive the necessity of your demanding the said debt from the Applicant before presenting us with the demand.

We further agree that no change or addition to or other modification of the terms of the Contract or of the Goods and related Services to be supplied thereunder or of any of the Contract documents which may be made between you and the Applicant shall in any way release us from

²⁰ _____
In the case of a JV, insert the name of the Joint Venture

²¹ *An amount shall be inserted by the Guarantor, representing the percentage of the Contract Price specified in the Contract and denominated in Indian Rupees.*

any liability under this guarantee, and we hereby waive notice of any such change, addition or modification.

This guarantee shall be valid until (i.e.) 60 days following the Completion date of the Contract including any warranty obligations²², and any demand for payment under it must be received by us at this office on or before that date.

Signature and seal of the guarantor _____

Name of Bank _____

Address _____

Date _____

Note: All italicized text (including footnotes) is for use in preparing this form and shall be deleted from the final product.

²²Completion date as described in GC Clause 18.4

4. Advance Payment Security Demand Guarantee

[Guarantor letterhead or SWIFT identifier code]

Advance Payment Guarantee No.....*[insert guarantee reference number]*

Date.....*[insert date of issue of the guarantee]*

To: _____ *[name of Purchaser]*
_____ *[address of Purchaser]*
_____ *[name of Contract]*

Gentlemen:

In accordance with the provisions of the Conditions of Contract, Clause 16 ("Terms of Payment") of the above-mentioned Contract, _____ *[name and address of Supplier²³]* (hereinafter called "the Applicant") shall deposit with _____ *[name of Purchaser]* a bank guarantee to guarantee his proper and faithful performance under the said Clause of the Contract in an amount of _____ *[amount of guarantee²⁴]* _____ *[in words]*.

We, the _____ *[bank or financial institution]*, as instructed by the Applicant, agree unconditionally and irrevocably to guarantee as primary obligator and not as Surety merely, the payment to _____ *[name of Purchaser]* on his first demand without whatsoever right of objection on our part and without his first claim to the Applicant, in the amount not exceeding _____ *[amount of guarantee]* _____ *[in words]*.

We further agree that no change or addition to or other modification of the terms of the Contract or of Goods and related Services to be supplied thereunder or of any of the Contract documents which may be made between _____ *[name of Purchaser]* and the Applicant, shall in any way release us from any liability under this guarantee, and we hereby waive notice of any such change, addition or modification.

This guarantee shall remain valid and in full effect from the date of the advance payment under the Contract until _____ *[name of Purchaser]* receives full

²³In the case of a JV, insert the name of the Joint Venture

²⁴An amount shall be inserted by the bank representing the amount of the Advance Payment, and denominated in Indian Rupees.

repayment of the same amount from the Applicant. Consequently, any demand for payment under this guarantee must be received by us at this office on or before that date.

Yours truly,

Signature _____ and _____ seal:

Name of Bank: _____

Address:

Date: _____

Note: All italicized text (including footnotes) is for use in preparing this form and shall be deleted from the final product.

ⁱ*Substitute by “contracts” where Bids are invited concurrently for multiple contracts. In all such cases add a new para. 3 as follows: “Bidders may Bid for one or several contracts, as further defined in the bidding document. Bidders wishing to offer discounts in case they are awarded more than one contract will be allowed to do so, provided those discounts are included in the Letter of Bid, and renumber paras 3 - 8.”*